

PREFACE

Thank you for selecting FST-800 series frequency inverter from Shenzhen Anyhertz Drive Co., Ltd.

The FST-800 Drive is a series of high performance general frequency inverter with 3 kinds of control methods—V/F control, control sensorless vector control, closed-loop vector control. It has abundant parameter functions including torque control, droop function, slip compensation, dwell function, zero servo function, multi-step speed and simple PLC setting, PID setting, speed tracing. It is applicable in many situations which needs accurate speed control, fast torque response speed and high start-torque.

In order to make good use of the product and insure the user's safety, read through the manual before installing or operating the FST-800 inverter. And keep it carefully after your reading.

When you have any questions that is not answered in this manual, please contact the local dealers or our company, our professional staff will be ready for you. Please keep on paying attention to our products.

*****WARNING*******Precautions**

- 1) Read this manual in its entirety before installing or operating the FST-800 inverter.
- 2) Do not connect or disconnect wiring, or perform signal checks while the power supply is turned ON.
- 3) The FST-800 Drive internal capacitor is still charged even after the power supply is turned OFF. To prevent electrical shock, disconnect all power before servicing the inverter. Then wait at least one minute after the power supply is disconnected and all LED's are extinguished.
- 4) Do not perform a withstand voltage test or a megger test on any part of the FST-800 Drive. This electronic equipment uses semiconductors and is vulnerable to high voltage.
- 5) Do not remove the operator unless the power supply is turned OFF. Never touch the printed control board while the power supply is turned ON.
- 6) The FST-800 Drive is suitable for use on a circuit capable of delivering not more than 65,000 RMS symmetrical amperes, 600 Volts maximum (575V class units), 480 Volts maximum (460V class units), and 240 Volts maximum (230V class units).

Failure to observe these and other precautions highlighted in this manual will expose the user to high voltages, resulting in equipment damage, serious injury or death.

CONTENTS

| | |
|---|----|
| PREFACE..... | 1 |
| CONTENTS..... | 3 |
| CHAPTER 1 RECEIVING & INSTALLATION..... | 5 |
| 1.1 INTRODUCTION..... | 5 |
| 1.2 SOFTWARE VERSION EXPLANATION..... | 6 |
| 1.3 FST-800 SERIES SPECIFICATIONS..... | 7 |
| 1.4 MOUNTING..... | 11 |
| 1.5 WIRING..... | 14 |
| CHAPTER 2 OPERATION..... | 27 |
| 2.1 TRIAL OPERATION..... | 28 |
| 2.2 DIGITAL OPERATOR DISPLAY..... | 32 |
| 2.3 OPERATION MODE SELECTION..... | 33 |
| CHAPTER 3 QUICK-START PROGRAMMING..... | 34 |
| 3.1 MAIN MENU: INITIALIZE <ENTER>..... | 35 |
| 3.2 MAIN MENU: PROGRAMMING <ENTER>..... | 36 |
| 3.3 MAIN MENU: AUTO-TUNING <ENTER>..... | 47 |
| CHAPTER 4 DIAGNOSTICS..... | 48 |
| 4.1 MAINTENANCE & INSPECTION..... | 49 |
| 4.2 ALARM & FAULT DISPLAYS..... | 50 |
| CHAPTER 5 COPY MODE GUIDE..... | 55 |
| 5.1. COPY MODE SPECIFICATION:..... | 55 |
| 5.2. COPY MODE EXPLANATION..... | 55 |
| 5.3. OPERATION..... | 56 |
| 5.3.1 COPY MODE USER GUIDE:..... | 56 |
| 5.3.2 COPY MODE OPERATION GUIDE..... | 57 |
| 5.4. ERROR MESSAGE..... | 58 |

| | |
|---|------------|
| CHAPTER 6 MENL PARAMETER | 59 |
| MAIN MENU: INITIALIZE <ENTER> | 63 |
| A INITIALIZATION PARAMETERS..... | 63 |
| MAIN MENU: PROGRAMMING <ENTER> | 65 |
| B APPLICATION PARAMETERS..... | 65 |
| C TUNING PARAMETERS..... | 83 |
| D REFERENCE PARAMETERS..... | 98 |
| E MOTOR PARAMETERS..... | 106 |
| F OPTION PARAMETERS..... | 116 |
| H CONTROL CIRCUIT TERMINAL PARAMETERS..... | 128 |
| H1 DIGITAL INPUTS..... | 128 |
| L PROTECTION PARAMETERS..... | 154 |
| O OPERATOR PARAMETERS..... | 170 |
| MAIN MENU: AUTO-TUNING <ENTER> | 175 |
| 1. PARAMETER LIST | 176 |
| 2. MONITOR DISPLAY (UN-XX) | 204 |

CHAPTER 1 RECEIVING & INSTALLATION

1.1 INTRODUCTION

The FST-800 Drive, a series of high quality, general-purpose inverters with flux vector control, directly controls the current (or torque) in an AC induction motor. With an initial power range of 0.5 to 500 HP, it is suited for any application, and provides smooth start-up at low speeds, and extremely precise operation. It's proprietary auto-tuning function enables high-performance tuning of motors manufactured worldwide.

The FST-800 Drive combines four control methods into one compact drive, including flux vector and conventional V/f control. From precision machinery to multiple motor drives, the FST-800 Drive proves to be the **Ultimate** drive for any application. This functionality includes Anyhertz proprietary features like Adaptive Vector Control (AVC™), full-range automatic torque boost, auto-tuning, UL-recognized electronic thermal motor overload, energy savings operation, PID control, low-noise operation and various other features. It also features a 2-line × 16-character, alphanumeric digital operator for simple programming in seven different languages. Utilizing the latest microprocessor technology, members of Yaskawa design team have collaborated to make the FST-800 Drive the **Ultimate** drive for any application.

This manual details installation, quick-start and diagnostic procedures for the FST-800 Drive series adjustable frequency drive controller. For more detailed descriptions of programming procedures, contact your Anyhertz representative.

1.2 SOFTWARE VERSION EXPLANATION

Anyhertz recognizes the need to continuously improve product quality. This product may receive feature enhancements in the form of software or hardware changes. New programming parameters will be added to the latest programming manual. When a new parameter is added a software version note will be placed next to the parameter.

Software Version Example:

For Parameter A1-00, select the language displayed on the digital operator according to the following table:

| Setting | Description |
|---------|------------------------------------|
| 0 | English (<i>factory default</i>) |
| 1 | Traditional Chinese |
| 2 | Simplified Chinese |
| 3 | German |
| 4 | French |
| 5 | Russian |
| 6 | Spanish |

The part number of the main control printed circuit board on the drive reflects the software version. The software version normally increases to a higher number with newer versions. Please consult the factory for details.

1.3 FST-800 Series SPECIFICATIONS

230V

| Inverter Model FST-800 | | FST-800 | | | | | | | | | | | | | | | |
|---------------------------|-----------------------------|--|-----|------|------|------|------|------|------|------|------|------|------|------|------|------|------|
| | | 0R4 | 0R7 | 21P5 | 22P2 | 23P7 | 25P5 | 27P5 | 2011 | 2015 | 2018 | 2022 | 2030 | 2037 | 2045 | 2055 | 2075 |
| Output Characteristics | Nominal Motor Output (HP) * | 0.5 | 1 | 2 | 3 | 5 | 7.5 | 10 | 15 | 20 | 25 | 30 | 40 | 50 | 60 | 75 | 100 |
| | Capacity (kVA)** | 1.2 | 2.3 | 3.0 | 4.2 | 6.7 | 9.5 | 13 | 19 | 24 | 30 | 37 | 50 | 61 | 70 | 85 | 110 |
| | Rated Output Current (A) # | 3.2 | 6 | 8 | 11 | 17.5 | 25 | 33 | 49 | 64 | 80 | 96 | 130 | 160 | 183 | 224 | 300 |
| | Max. Voltage | 3-Phase, 200/208/220/230V (Proportional to input voltage) | | | | | | | | | | | | | | | |
| | Rated Output Frequency | Up to 400 Hz available | | | | | | | | | | | | | | | |
| | Overload Capacity | 150% Rated Current / 1 minute | | | | | | | | | | | | | | | |
| Power Supply | Input Current (A) | 3.9 | 7.2 | 9.6 | 13.2 | 21 | 30 | 40 | 59 | 77 | 88 | 106 | 143 | 176 | 202 | 247 | 330 |
| | Rated Voltage & Frequency | 3-Phase 200 to 230V, 50/60Hz | | | | | | | | | | | | | | | |
| | Voltage Fluctuation | +10%, -15% | | | | | | | | | | | | | | | |
| | Frequency Fluctuation | ±5% | | | | | | | | | | | | | | | |

460V

| FST-800 | | 0R4 | 0R7 | 1R5 | 2R2 | 3R7 | 5R5 | 7R5 | 011 | 015 | 018 | 022 | 030 | 037 | 045 | 055 | 075 | 110 | 132 | 160 | 185 | 250 | 300 |
|------------------------|-----------------------------|---|-----|-----|-----|------|------|------|-----|------|-----|-----|-----|-----|-----|-----|-----|-----|-----|-----|-----|-----|-----|
| Output Characteristics | Nominal Motor Output (HP)* | 0.5 | 1 | 2 | 3 | 5 | 7.5 | 10 | 15 | 20 | 25 | 30 | 40 | 50 | 60 | 75 | 100 | 125 | 150 | 200 | 250 | 350 | 500 |
| | Capacity (kVA)" | 1.4 | 2.6 | 3.7 | 4.7 | 6.1 | 8.4 | 11 | 16 | 21 | 26 | 31 | 40 | 50 | 61 | 73 | 98 | 130 | 170 | 230 | 260 | 340 | 460 |
| | Rated Output Current (A)# | 1.9 | 3.6 | 5.1 | 6.6 | 8.5 | 11.7 | 14.8 | 21 | 28.6 | 34 | 41 | 52 | 65 | 80 | 96 | 128 | 165 | 224 | 302 | 340 | 450 | 605 |
| | Max. Voltage | 3-Phase, 380/400/415/440 (Proportional to input voltage) | | | | | | | | | | | | | | | | | | | | | |
| | Rated Output Frequency | Up to 400 Hz available | | | | | | | | | | | | | | | | | | | | | |
| | Overload Capacity | 150% Rated Current / 1 minute | | | | | | | | | | | | | | | | | | | | | |
| Power Supply | Input Current (A) | 2.3 | 4.3 | 6.1 | 8 | 10.2 | 14 | 17.8 | 26 | 35 | 40 | 46 | 58 | 72 | 88 | 106 | 141 | 182 | 247 | 330 | 408 | 540 | 726 |
| | Rated Voltage & Frequency # | 3-Phase 380 to 460V, 50/60Hz | | | | | | | | | | | | | | | | | | | | | |
| | Voltage Fluctuation | +10%, -15% | | | | | | | | | | | | | | | | | | | | | |
| | Frequency Fluctuation | ±5% | | | | | | | | | | | | | | | | | | | | | |

FST-800 Series SPECIFICATIONS (continued)
575V

| Inverter Model FST-800 | | | FST-800 | | | | | | | | | | | | | | | | |
|------------------------|-----------------------------|--|--|------|------|------|------|------|------|------|------|------|------|------|------|------|------|------|------|
| | | | 51P5 | 52P2 | 53P7 | 55P5 | 57P5 | 5011 | 5015 | 5018 | 5022 | 5030 | 5037 | 5045 | 5055 | 5075 | 5090 | 5110 | 5160 |
| Output Characteristics | Nominal Motor Output (HP) * | Constant Torque | 2 | 3 | 5 | 7.5 | 10 | 15 | 20 | 25 | 30 | 40 | 50 | 60 | 75 | 100 | 125 | 150 | 200 |
| | | Variable Torque | 3 | 3 | 5 | 10 | 10 | 15 | 20 | 25 | 30 | 40 | 50 | 60 | 75 | 100 | 150 | 200 | 200 |
| | Capacity (kVA) ** | | 2 | 3 | 5 | 7.5 | 10 | 15 | 20 | 25 | 30 | 40 | 50 | 60 | 75 | 100 | 125 | 150 | 200 |
| | Rated Output Current (A) # | Constant Torque (A) | 3.5 | 4.1 | 6.3 | 9.8 | 12.5 | 17 | 22 | 27 | 32 | 41 | 52 | 62 | 77 | 99 | 130 | 172 | 200 |
| | | Variable Torque (A) | 3.9 | 4.6 | 7 | 11 | 14 | 19 | 25 | 30 | 36 | 46 | 58 | 69 | 86 | 111 | 145 | 192 | 224 |
| | Maximum Voltage | | 3-Phase, 500/575/600V(Proportional to input voltage) | | | | | | | | | | | | | | | | |
| | Rated Output Frequency | | Up to 400 Hz available | | | | | | | | | | | | | | | | |
| Overload Capacity | | 150% Rated Current / 1 minute (CT rating) 120% Rated Current / 1 minute (VT rating) | | | | | | | | | | | | | | | | | |
| Power Supply | Input Current (A) | | 4.3 | 5.1 | 7.7 | 12.1 | 15.4 | 21 | 28 | 33 | 40 | 51 | 64 | 76 | 95 | 122 | 160 | 211 | 246 |
| | Rated Voltage & Frequency | | 3-Phase, 500 to 600V, 50/60Hz | | | | | | | | | | | | | | | | |
| | Voltage Fluctuation | | +10%, -15% | | | | | | | | | | | | | | | | |
| | Frequency Fluctuation | | ±5% | | | | | | | | | | | | | | | | |

* HP ratings based on NEMA 4-pole motor data. However, when sizing a drive to match a motor, use output current ratings.

For proper operation, the motor rated current must be less than or equal to the inverter rated current.

** kVA ratings are based on 200V, 400V, and 600V inputs respectively.

FST-800 Drive SPECIFICATIONS (continued)

| | | |
|--------------------------|------------------------------|--|
| Control Characteristics | Control Method | Sine wave PWM |
| | Starting Torque | 150% below 1Hz (150% at 0 rpm with PG) |
| | Speed Control Range | 100:1 (1000:1 with PG) |
| | Speed Control Accuracy | ±0.2% (±0.02% with PG) |
| | Speed Response | 5Hz (30Hz with PG) |
| | Torque Limit | Can be set by parameter: 4 quadrant control |
| | Torque Accuracy | ±5% |
| | Torque Response | 20Hz (40Hz with PG) |
| | Frequency Control Range | 0.1 to 400 Hz |
| | Frequency Accuracy | Digital command: 0.01%, Analog command: 0.1% |
| | Frequency Setting Resolution | Digital Operator Reference: 0.01Hz Analog Reference: 0.03Hz (@60Hz) |
| | Output Frequency Resolution | 0.01 Hz |
| | Frequency Setting Signal | -10 to +10V, 0 to +10V, 4 to 20mA |
| | Accel/Decel Time | 0.0 to 6000.0 sec. (Accel/Decel time setting independently, 4 steps available) |
| | Braking Torque | Approx. 20% |
| Protective Functions | Motor Overload Protection | UL-recognized electronic thermal overload relay (I2T) |
| | Instantaneous Overcurrent | Motor coasts to stop at approximately 200% rated output current. (CT Rating) |
| | Fuse Protection | Motor coasts to stop at blown fuse. |
| | Overload | Motor coasts to stop after 1 min. at 150% rated output current. (CT Rating) |
| | Overvoltage | Motor coasts to stop if converter output voltage exceeds 410VDC (820VDC at 460V input, 1040VDC at 575V input) |
| | Undervoltage | Motor coasts to stop if converter output voltage drops below user adjustable value |
| | Momentary Power Loss | Immediately stop after 15 ms or longer power loss. (Continuous system operation during power loss less than 2s is equipped as standard.) |
| | Heatsink Overheat | Thermistor - OH1, OH2 |
| | Stall Prevention | Stall prevention during acceleration, deceleration and constant speed operation |
| | Ground Fault | Provided by electronic circuit (overcurrent level) |
| | Power Charge Indication | Charge LED stays on until bus voltage drops below 50VDC |
| | Input Phase Loss | Single-phase protection |
| Environmental Conditions | Location | Indoor (protected from corrosive gases and dust) |
| | Ambient Temperature | +14 to 104°F (-10 to 40°C) for NEMA 1 type +14 to 113°F (-10 to 45°C) for Open Chassis type |
| | Storage Temperature | -4 to 140°F (-20 to 60°C) |
| | Humidity | 95% RH (non-condensing) |
| | Vibration | 9.8m/s ² (1G) less than 20Hz, up to 1.96m/s ² (0.2G) at 20 to 50Hz |

1.4 MOUNTING

CAUTION

Precautions

- A. When preparing to mount the FST-800 Drive, lift it by its base. Never lift it by the front cover.
- B. Mount the inverter onto nonflammable material.
- C. The FST-800 drive generates heat. For the most effective cooling possible, mount it vertically. For more details, refer to “Dimensions/Heat Loss” and “Clearances”. For mounting configurations other than normal vertical mounting, please consult the factory.
- D. When mounting units in an enclosure, install a fan or other cooling device to keep the intake air temperature below 113°F (45°C).

Failure to observe these precautions may result in equipment damage.

Choosing a Location

Be sure that the inverter is mounted in a location protected against the following conditions:

- Extreme cold and heat. Use only within the ambient temperature range:

NEMA 1: 14 to 104°F (-10 to 40°C).

Open Chassis: 14 to 113°F (-10 to 45°C)

- Direct sunlight (not for use outdoors)
- Rain, moisture
- High humidity
- Oil sprays, splashes
- Salt spray
- Dust or metallic particles in the air
- Corrosive gases (e.g. sulfurized gas) or liquids
- Radioactive substances
- Combustibles (e.g. thinner, solvents, etc.)
- Physical shock, vibration
- Magnetic noise (e.g. welding machines, power devices, etc.)

Removing and Replacing the Digital Operator (Pls. refer to the actual inverters due to updated designs)

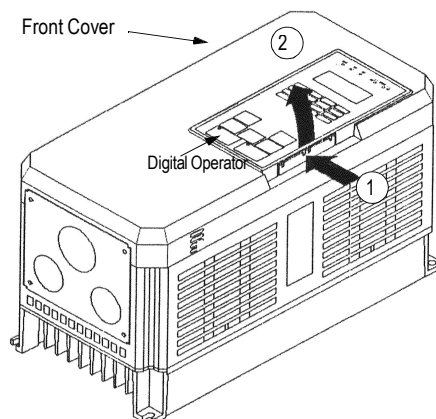

To remove the digital operator from the front cover, push the operator retaining tab in the direction shown by arrow 1 and lift the digital operator in the direction shown by arrow 2.

Figure 4 Removing the Digital Operator

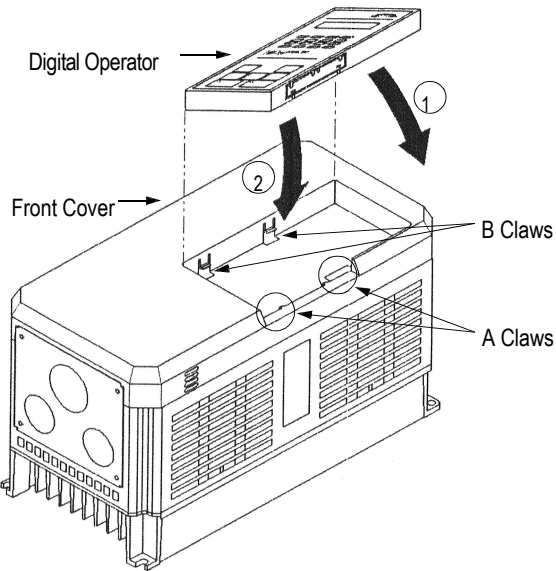

To replace the digital operator, engage the operator onto the A tabs in the direction shown by arrow 1 and then press the operator onto the B tabs in the direction shown by arrow 2, locking the digital operator into place.

Figure 5 Replacing the Digital Operator

Removing and Replacing the Front Cover (Pls. refer to the actual inverter due to updated designs)

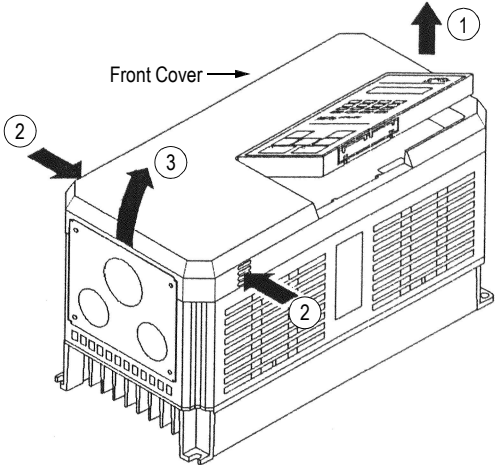

To remove the front cover, first remove the digital operator (see previous section). Then squeeze the cover on both sides in the direction shown by arrows 2 and lift the cover in the direction shown by arrow 3.

Figure 6 Removing and Replacing the Front Cover

Clearances

When mounting the FST-800 Drive, allow sufficient clearances for effective cooling as shown below:

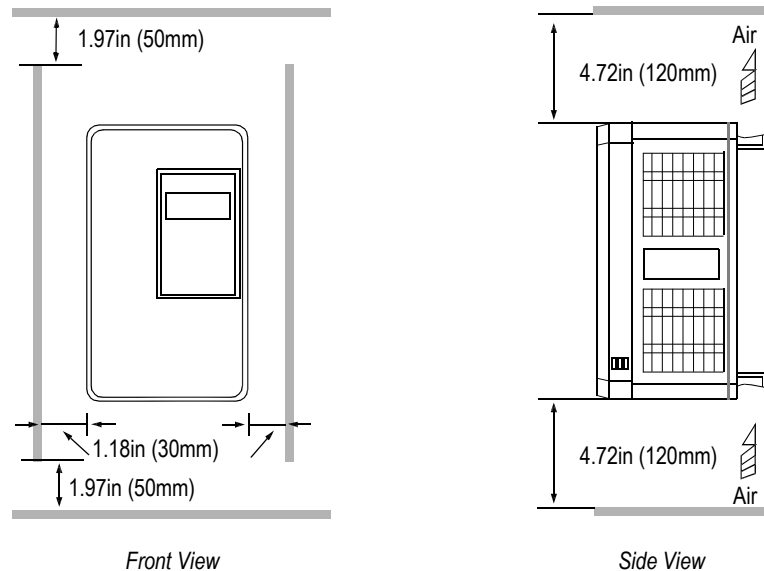

**Figure 8 FST-800 Series
Clearances**

Notes:

- ▶ The required clearances at the top, bottom, and both sides of the inverter are the same for both open chassis and NEMA 1 enclosures.
- ▶ For inverter models 25HP and less (230V & 460V), and models 20HP and less (575V), remove the top and bottom covers to convert NEMA 1 units to open chassis.
- ▶ Allowable intake air temperature: Open chassis: 14°F to 113°F (-10°C to +45°C) NEMA 1: 14°F to 104°F (-10°C to 40°C)
- ▶ When mounting units in an enclosure, install a fan or other cooling device to limit the air temperature within the inverter to below 113°F (45°C).

1.5 WIRING

CAUTION

Precautions

1. Do not connect or disconnect wiring, or perform signal checks while the power supply is turned ON.
2. Connect the power supply wiring to terminals L1, L2 and L3 on the main circuit input section. DO NOT connect the power supply wiring to output terminals T1, T2 and T3.
3. Connect the motor wiring to terminals T1, T2 and T3 on the main circuit output section.
4. *Never* touch the output circuit directly or place the output line in contact with the inverter enclosure.
5. Do not connect a phase-advancing capacitor or an LC/RC noise filter to the output circuit.
6. The motor wiring must be less than 328ft (100m) in length, and it is strongly recommended that it be in a separate conduit from all other wiring.
7. Control wiring must be less than 164ft (50m) in length and in a separate conduit from the power wiring.
8. Tighten the screws on the main circuit and control circuit terminals.
9. Low voltage wires shall be wired with Class 1 wiring.
10. Please observe national electrical code (NEC) when wiring electrical devices.

Failure to observe these precautions may result in equipment damage.

Inspection

After wiring is complete, verify that: All wiring is correctly installed.

Excess screws and wire clippings are removed from inside of the unit.

Screws are securely tightened.

Exposed wire has no contact with other wiring or terminals.

FST-800 Drive Standard Connection Diagram

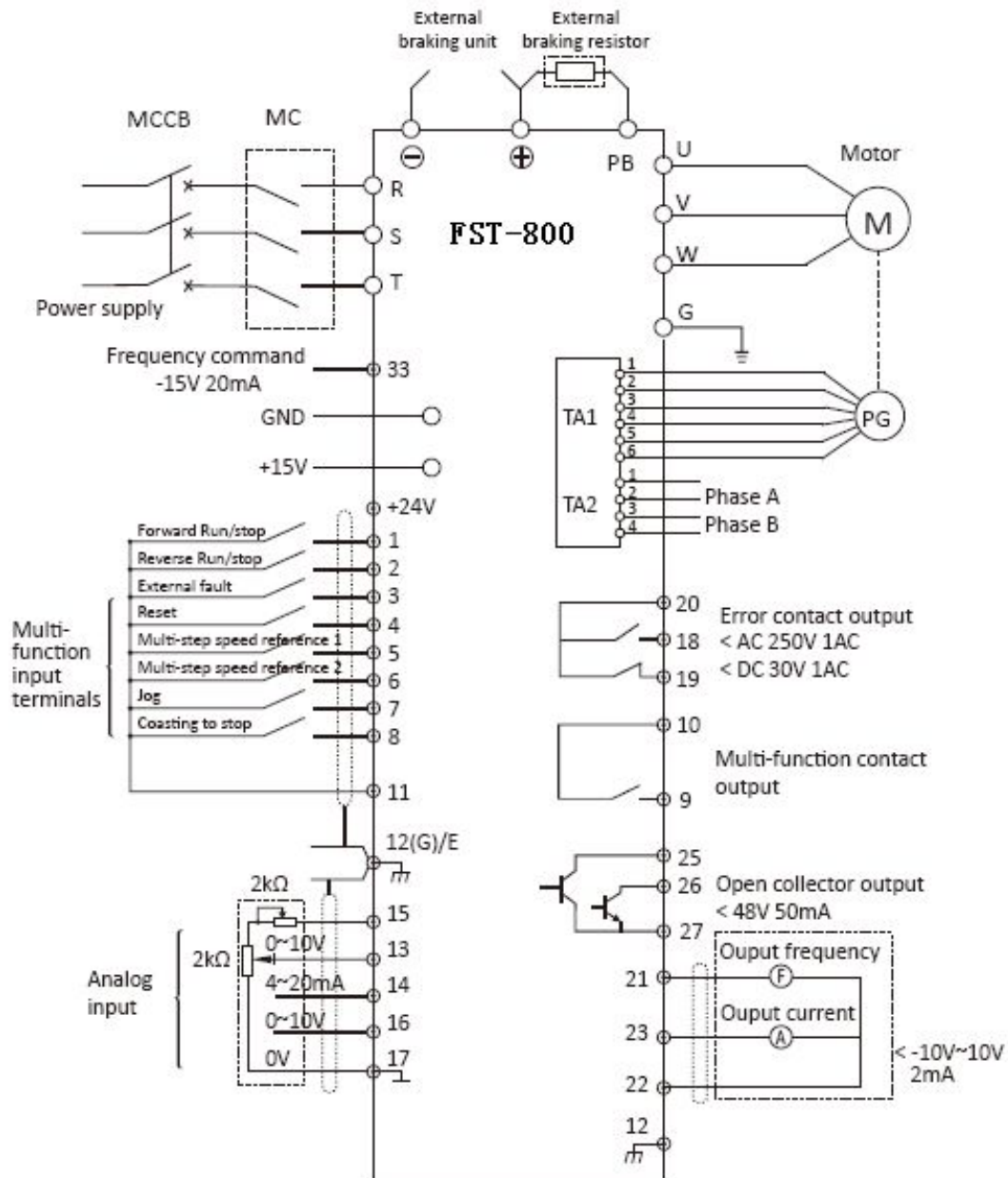

Main Circuit Wiring

Input Wiring

- **Molded-Case Circuit Breaker (MCCB)**

Be sure to connect MCCBs or fuses between the AC main circuit power supply and FST-800 Drive input terminals L1, L2 and L3, to protect the input wiring.

- **Ground Fault Interrupter**

When connecting a ground fault interrupter to input terminals L1, L2 and L3, select one that is not affected by high frequency.

- **Magnetic Contactor (MC)**

Inverters can be used without an MC installed on the power supply side. When the main circuit power supply is shut OFF in the sequence, an MC can be used instead of an MCCB. However, when an MC is switched OFF on the primary side, dynamic braking does not function and the motor coasts to stop.

The load can be operated/stopped by opening/closing the MC on the primary side. However, frequent switching may cause the inverter to malfunction.

When using a braking resistor unit, use a sequencer to break the power supply side of the inverter in the event of an overload relay trip contact. If the inverter malfunctions, the braking resistor unit may be burned out.

- **Terminal Block Connection Sequence**

Input power supply phases can be connected to any terminal regardless of the order of L1, L2 and L3 on the terminal block.

- **AC Reactor**

When connecting an inverter (230V/460V/575V, 15kW or less) to a large capacity power supply transformer (600kVA or more), or when switching a phase-advancing capacitor, excessive peak current may flow through the input power supply circuit, which may damage the converter section. In such cases, install a DC reactor (optional) between inverter 1 and 2 terminals, or an AC reactor (optional) on the input side. Installation of a reactor is effective for improvement of power factor on the power supply side.

- **Surge Suppressor**

For inductive loads (i.e. magnetic contactors, magnetic relays, magnetic valves, solenoids, magnetic brakes, etc.) connected near the inverter, use a surge suppressor across the coil to minimize the inductive “kick” when energizing and de-energizing these devices.

Output Wiring

- **Motor Connection**

Connect motor lead wires to output terminals T1, T2 and T3. Verify that the motor rotates in the forward direction (CCW: counterclockwise when viewed from the motor load side) with the forward run command. If the motor rotation is incorrect, exchange any two of the motor leads.

- **Magnetic Starter**

Do not connect a magnetic starter or a magnetic contactor to the output circuit. If the motor load is connected or disconnected while the inverter is running, the inverter overcurrent protective circuitry may trip.

- **Thermal Overload Relay**

An Underwriter’s Laboratory (UL) recognized electronic overload protective function is incorporated into the inverter. However, when driving several motors with one inverter, or when switching

between multiple windings of a multiple winding motor, connect an external thermal overload relay. In this case, disable the inverter motor overload feature by setting parameter *L1-01* to “0”.

· **Wiring Distance Between Inverter and Motor**

If the total wiring distance between inverter and motor is excessively long and the inverter carrier frequency (IGBT switching frequency) is high, harmonic leakage current from the wiring may adversely affect the inverter and peripheral devices. If the wiring distance is long, reduce the inverter carrier frequency as described below. Carrier frequency can be set by parameter *C6-01*. Please note that motor audible noise may increase when lowering the carrier frequency.

Wiring Distance Between Inverter and Motor

| | | | |
|-------------------------|---------------|---------------|-------------------|
| Wiring Distance between | Up to 164 ft. | Up to 328 ft. | More than 328 ft. |
| Carrier Frequency | 15kHz or less | 10kHz or less | 5kHz or less |

Grounding

· Ground Resistance

230V class: 100 or less, 460V class: 10 or less, 575V class: 10 or less.

- Never ground the FST-800 Drive in common with welding machines, motors, or other high-current electrical equipment. Run all ground wiring in a separate conduit.
- Use ground wiring as specified in “Wire and Terminal Screw Sizes” on page 31, and keep the length as short as possible.
- When using several FST-800 Drive units side by side, ground the units as shown in Figure 12, (a) or (b). Do not loop the wires as shown in (c).

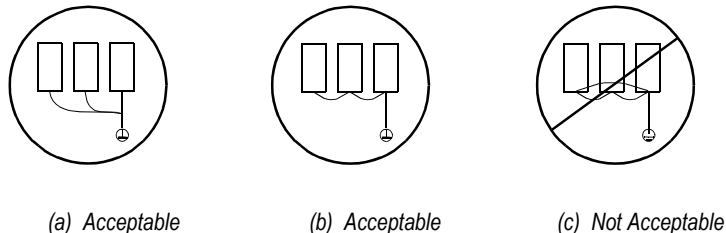

Figure 12 Grounding Example of 3 FST-800 Inverters

Terminal Functions

230V Class Terminal Functions

| Model FST-800 | 20P4 to 27P5 | 2011 to 2015 | 2018 to 2022 | 2030 to 2075 |
|----------------------|---|---|--|---|
| Nominal Motor Output | 0.5 to 10HP | 15 to 20HP | 25 to 30HP | 40 to 100HP |
| L1 | Main circuit input power supply | | | |
| L2 | | | | |
| L3 | | | | |
| T1 | Inverter output | | | |
| T2 | | | | |
| T3 | | | | |
| B1 | Braking resistor unit | --- | | |
| B2 | | | | |
| ⊖ | DC reactor (⊕ 1- ⊕ 2) DC power supply(⊕ 1-⊖) | DC reactor (⊕ 1- ⊕ 2) DC power supply(⊕ 1-⊖) Braking unit (⊕ 3-⊖) | DC power supply(⊕ 1-⊖) Braking unit (⊕ 3-⊖) | Braking unit (⊕ 3-⊖) (⊕ 1 and ⊕ 2 terminals not provided) |
| ⊕ 1 | | | | |
| ⊕ 2 | --- | | | |
| ⊕ 3 | --- | | | |
| r | --- | | Cooling fan power supply | |
| s | --- | | | |
| ⊖ | Ground terminal (Ground resistance: 100Ω or less) | | | |

460V Class Terminal Functions





















| Model FST-800 | 40P4 to 4015 | 4018 to 4045 | 4055 to 4160 | 4185 to 4300 |
|----------------------|---|--|---|-----------------------|
| Nominal Motor Output | 0.5 to 25HP | 30 to 75HP | 100 to 200HP | 250 to 500HP |
| L1 | Main circuit input power supply | | | |
| L2 | | | | |
| L3 | | | | |
| T1 | Inverter output | | | |
| T2 | | | | |
| T3 | | | | |
| B1 | Braking resistor unit | --- | | |
| B2 | | | | |
| ⊖ | DC reactor (⊕ 1- ⊕ 2) DC power supply(⊕ 1-⊖) | DC power supply(⊕ 1-⊖) Braking unit (⊕ 3-⊖) | Braking unit (⊕ 3-⊖) (⊕ 1 and ⊕ 2 terminals not provided) | Braking unit(⊕ 3-⊖) |
| ⊕ 1 | | | | |
| ⊕ 2 | --- | | | |
| ⊕ 3 | --- | | | |
| s | --- | | Cooling fan power supply | |
| r | --- | | Cooling fan power supply Control power supply | |
| s 200 | --- | | r - s 200: 200 to 230 VAC input | |
| s 400 | --- | | r - s 400: 380 to 460 VAC input | |
| ⊕ | Ground terminal (Ground resistance: 10Ω or less) | | | |

Terminal Functions (continued)

575V Class Terminal Functions

| Model FST-800 | 51P5 to 5015 | 5018 to 5022 | 5030 to 5160 |
|----------------------|--|--------------------------------------|---------------------------|
| Nominal Motor Output | 2.0 to 20HP | 25 to 30HP | 40 to 200HP |
| L1 | Main circuit input power supply | | |
| L2 | | | |
| L3 | | | |
| T1 | Inverter output | | |
| T2 | | | |
| T3 | | | |
| B1 | Braking resistor unit | | — |
| B2 | | | |
| ⊖ | DC reactor (⊕ 1- ⊕ 2) DC power supply(⊕ 1- ⊖) | DC power supply(⊕ 1- ⊖) | Braking unit(⊕ 1- ⊖) |
| ⊕ 1 | | | DC power supply(⊕ 1- ⊖) |
| ⊕ 2 | — | — | — |
| I 1 | — | Cooling fan and control power supply | |
| I 2 | — | | |
| Ⓧ | Ground terminal (Ground resistance: 10 Ω or less) | | |





















Wire and Terminal Screw Sizes
230V Class Wire Size

| Circuit | Model FST-800- | Terminal Symbol | Terminal Screw | Wire Size * | | Max. Torque lb-in (N·m) | Wire Type |
|---------|---|--|----------------|-------------|---------------------|-------------------------|--|
| | | | | AWG | mm ² | | |
| Main | 20P4 | L1, L2, L3,  , ⊕ 1, ⊕ 2, B1, B2, T1, T2, T3 | M4 | 14 - 10 | 2 - 5.5 | 12.4 (1.4) | Power cable: 600V vinyl sheathed wire or equivalent |
| | |  | | | | | |
| | 20P7 | L1, L2, L3,  , ⊕ 1, ⊕ 2, B1, B2, T1, T2, T3 | M4 | 14 - 10 | 2 - 5.5 | 12.4 (1.4) | |
| | |  | | | | | |
| | 21P5 | L1, L2, L3,  , ⊕ 1, ⊕ 2, B1, B2, T1, T2, T3 | M4 | 14 - 10 | 2 - 5.5 | 12.4 (1.4) | |
| | |  | | 12 - 10 | 3.5 - 5.5 | | |
| | 22P2 | L1, L2, L3,  , ⊕ 1, ⊕ 2, B1, B2, T1, T2, T3 | M4 | 12 - 10 | 3.5 - 5.5 | 12.4 (1.4) | |
| | |  | | | | | |
| | 23P7 | L1, L2, L3,  , ⊕ 1, ⊕ 2, B1, B2, T1, T2, T3 | M4 | 10 | 5.5 | 12.4 (1.4) | |
| | |  | | | | | |
| | 25P5 | L1, L2, L3,  , ⊕ 1, ⊕ 2, B1, B2, T1, T2, T3 | M5 | 8 | 8 | 22.1 (2.5) | |
| | |  | | 10 - 8 | 5.5 - 8 | | |
| | 27P5 | L1, L2, L3,  , ⊕ 1, ⊕ 2, B1, B2, T1, T2, T3 | M5 | 8 | 8 | 22.1 (2.5) | |
| | |  | | 10 - 8 | 5.5 - 8 | | |
| | 2011 | L1, L2, L3,  , ⊕ 1, ⊕ 2, ⊕ 3, T1, T2, T3 | M6 | 4 | 22 | 45.1 (5.1) | |
| | |  | | 8 | 8 | | |
| | 2015 | L1, L2, L3,  , ⊕ 1, ⊕ 2, ⊕ 3, T1, T2, T3 | M8 | 3 | 30 | 90.3 (10.2) | |
| | |  | M6 | 8 | 8 | | |
| | 2018 | L1, L2, L3,  , ⊕ 1, ⊕ 2, ⊕ 3, T1, T2, T3 | M8 | 3 | 30 | 90.3 (10.2) | |
| | |  | | 6 | 14 | | |
| 2022 | r, s | M4 | 20 - 10 | 0.5 - 5.5 | 12.4 (1.4) | | |
| | L1, L2, L3,  , ⊕ 1, ⊕ 2, ⊕ 3, T1, T2, T3 | | | | | M8 | 2 |
| 2030 |  | M8 | 4 | 22 | 90.3 (10.2) | | |
| | r, s | | | | | M4 | 20 - 10 |
| 2037 | L1, L2, L3, T1, T2, T3 | M10 | 1/0 x 2P | 60 x 2P | 203.6 (23.0) | | |
| |  | M8 | 4 | 22 | 90.3 (10.2) | | |
| 2045 | r, s | M4 | 20 - 10 | 0.5 - 5.5 | 12.4 (1.4) | | |
| | L1, L2, L3, T1, T2, T3 | | | | | M10 | 1/0 x 2P |
| 2055 |  | M8 | 3 | 30 | 90.3 (10.2) | | |
| | r, s | | | | | M4 | 20 - 10 |
| 2075 | L1, L2, L3, T1, T2, T3 | M12 | 4/0 x 2P | 100 x 2P | 349.6 (39.5) | | |
| |  | M8 | 1 | 50 | 90.3 (10.2) | | |
| Control | Common to all models | 1-33 | M3.5 | 20 - 16 | Stranded 0.5 - 1.25 | - | Twisted shielded wire with Class 1 wiring |
| | | G | | | | | |

* Wire sizes are based on 75°C copper wire.

Wire and Terminal Screw Sizes

460V Class Wire Size

| Circuit | Model FST-800 | Terminal Symbol | Terminal Screw | Wire Size * | | Max. Torque lb-in (N·m) | Wire Type |
|---------|------------------|---|-------------------|-------------|-----------------|----------------------------|--|
| | | | | AWG | mm ² | | |
| Main | 40P4 | L1, L2, L3,  , ⊕ 1, ⊕ 2, B1, B2, T1, T2, T3 | M4 | 14 - 10 | 2 - 5.5 | 12.4 (1.4) | Power cable: 600V vinyl sheathed wire or equivalent |
| | 40P7 | L1, L2, L3,  , ⊕ 1, ⊕ 2, B1, B2, T1, T2, T3 | M4 | 14 - 10 | 2 - 5.5 | 12.4 (1.4) | |
| | 41P5 | L1, L2, L3,  , ⊕ 1, ⊕ 2, B1, B2, T1, T2, T3 | M4 | 14 - 10 | 2 - 5.5 | 12.4 (1.4) | |
| | 42P2 | L1, L2, L3,  , ⊕ 1, ⊕ 2, B1, B2, T1, T2, T3 | M4 | 14 - 10 | 2 - 5.5 | 12.4 (1.4) | |
| | 43P7 | L1, L2, L3,  , ⊕ 1, ⊕ 2, B1, B2, T1, T2, T3 | M4 | 14 - 10 | 2 - 5.5 | 12.4 (1.4) | |
| | 44P0 | L1, L2, L3,  , ⊕ 1, ⊕ 2, B1, B2, T1, T2, T3 | M4 | 12 - 10 | 3.5 - 5.5 | 12.4 (1.4) | |
| | 45P5 | L1, L2, L3,  , ⊕ 1, ⊕ 2, B1, B2, T1, T2, T3 | M4 | 12 - 10 | 3.5 - 5.5 | 12.4 (1.4) | |
| | 47P5 | L1, L2, L3,  , ⊕ 1, ⊕ 2, B1, B2, T1, T2, T3 | M5 | 8 - 6 | 8 - 14 | 22.1 (2.5) | |
| | 4011 | L1, L2, L3,  , ⊕ 1, ⊕ 2, B1, B2, T1, T2, T3 | M5 | 8 - 6 | 8 - 14 | 22.1 (2.5) | |
| | 4015 |  , ⊕ 1, ⊕ 2, B1, B2, T1, T2, T3 | M6 | 8 | 8 | 45.1 (5.1) | |
| | | | M5 | 8-6 | 8 - 14 | 22.1 (2.5) | |
| | 4018 | L1, L2, L3,  , ⊕ 1, ⊕ 2, ⊕ 3, T1, T2, T3 | M6 | 6 | 14 | 45.1 (5.1) | |
| | | | M8 | 8 | 8 | 90.3 (10.2) | |
| | 4022 | L1, L2, L3,  , ⊕ 1, ⊕ 2, ⊕ 3, T1, T2, T3 | M4 | 20 - 10 | 0.5 - 5 | 12.4 (1.4) | |
| | | | M6 | 4 | 22 | 45.1 (5.1) | |
| | 4030 | L1, L2, L3,  , ⊕ 1, ⊕ 2, ⊕ 3, T1, T2, T3 | M4 | 20 - 10 | 0.5 - 5 | 12.4 (1.4) | |
| | | | M8 | 8 | 8 | 90.3 (10.2) | |
| | 4037 | L1, L2, L3,  , ⊕ 1, ⊕ 2, ⊕ 3, T1, T2, T3 | M4 | 20 - 10 | 0.5 - 5 | 12.4 (1.4) | |
| | | | M8 | 3 | 30 | 90.3 (10.2) | |
| | 4045 | L1, L2, L3,  , ⊕ 1, ⊕ 2, ⊕ 3, T1, T2, T3 | M4 | 20 - 10 | 0.5 - 5 | 12.4 (1.4) | |
| | | | M8 | 6 | 14 | 90.3 (10.2) | |
| | 4055 | L1, L2, L3, T1, T2, T3  ,  , ⊕ 3 | M4 | 20 - 10 | 0.5 - 5 | 12.4 (1.4) | |
| | | | M8 | 4 | 22 | 90.3 (10.2) | |
| | 4075 | L1, L2, L3, T1, T2, T3  ,  , ⊕ 3 | M4 | 20 - 10 | 0.5 - 5 | 12.4 (1.4) | |
| | | | M10 | 1/0 x 2P | 60 x 2P | 203.6 (23.0) | |
| | 4110 | L1, L2, L3, T1, T2, T3  ,  , ⊕ 3 | M4 | 20 - 10 | 0.5 - 5 | 12.4 (1.4) | |
| | | | M8 | 3 | 30 | 90.3 (10.2) | |

| | | | | | | | |
|---------|----------------------|-------------------------------------|------|-------------|---|--------------|---|
| | | L1, L2, L3, T1, T2, T3 | M12 | 4/0 x 2P | 100 x 2P | 349.6 (39.5) | |
| 4160 | | ⊕, ⊖, ⊕ 3 r, s200, s400 | M8 | 1 | 50 | 90.3 (10.2) | |
| | | L1, L2, L3, ⊖, ⊕ 1, ⊕ 3, T1, T2, T3 | M4 | 20 - 10 | 0.5 - 5 | 12.4 (1.4) | |
| 4185 | | ⊕ r, s200, s400 | M16 | 650MCM x 2P | 325 x 2P | 867.4 (98.0) | |
| | | L1, L2, L3, ⊖, ⊕ 1, ⊕ 3, T1, T2, T3 | M8 | 20 - 10 | 0.5 - 5.5 | 12.4 (1.4) | |
| 4220 | | ⊕ r, s200, s400 | M16 | 650MCM x 2P | 325 x 2P | 867.4 (98.0) | |
| | | L1, L2, L3, ⊖, ⊕ 1, ⊕ 3, T1, T2, T3 | M8 | 1/0 | 60 | 90.3 (10.2) | |
| 4300 | | ⊕ r, s200, s400 1-33 | M4 | 20 - 10 | 0.5 - 5.5 | 12.4 (1.4) | |
| | | | M16 | 650MCM x 2P | 325 x 2P | 867.4 (98.0) | |
| | | | M8 | 1/0 | 60 | 90.3 (10.2) | |
| Control | Common to all Models | | M4 | 20 - 10 | 0.5 - 5.5 | 12.4 (1.4) | |
| | | | M16 | 650MCM x 2P | 325 x 2P | 867.4 (98.0) | |
| | | | M8 | 1/0 | 60 | 90.3 (10.2) | |
| | | | M4 | 20 - 10 | 0.5 - 5.5 | 12.4 (1.4) | |
| | | | M3.5 | 20 - 16 | Stranded 0.5 - 1.25 Solid 0.5 - 1.25 | - | Twisted shielded wire with Class 1 wiring |
| | | G | M3.5 | 20 - 14 | 0.5 - 2 | 8.9 (1.0) | |

* Wire sizes are based on 75°C copper wire.

Wire and Terminal Screw Sizes (continued)
575V Class Wire Size

| Circuit | Model FST-800 | Terminal Symbol | Terminal Screw | Wire Size * | | Max. Torque lb- in (N·m) | Wire Type | | | | | |
|---------------------------------|--------------------------------|---|-------------------|-------------|---|---------------------------------|--|---------------------------------|------------|------------|---------|------------|
| | | | | AWG | mm ² | | | | | | | |
| Main | 51P5 52P2 | L1, L2, L3, ⊖, ⊕ 1, ⊕ 2, B1, B2, T1, T2, T3 | M4 | 14 - 10 | 2 - 5.5 | 12.4 (1.4) | Power cable: 600V vinyl sheathed wire or equivalent | | | | | |
| | | ⊕ | | | | | | | | | | |
| | 53P7 | L1, L2, L3, ⊖, ⊕ 1, ⊕ 2, B1, B2, T1, T2, T3 | M4 | 14 - 10 | 2 - 5.5 | 12.4 (1.4) | | | | | | |
| | | | | ⊕ | 12 - 10 | | | 3.5 - 5.5 | | | | |
| | 55P5 | L1, L2, L3, ⊖, ⊕ 1, ⊕ 2, B1, B2, T1, T2, T3 | M4 | 12 - 10 | 3.5 - 5.5 | 12.4 (1.4) | | | | | | |
| | | | | ⊕ | | | | | | | | |
| | 57P5 | L1, L2, L3, ⊖, ⊕ 1, ⊕ 2, B1, B2, T1, T2, T3 | M4 | 10 | 5.5 | 12.4 (1.4) | | | | | | |
| | | | | ⊕ | 12 - 10 | | | 3.5 - 5.5 | | | | |
| | 5011 | L1, L2, L3, ⊖, ⊕ 1, ⊕ 2, B1, B2, T1, T2, T3 | M5 | 10 - 6 | 5.5 - 14 | 12.4 (1.4) | | | | | | |
| | | | ⊕ | | | | | M6 | 45.1 (5.1) | | | |
| | 5015 | L1, L2, L3, ⊖, ⊕ 1, ⊕ 2, B1, B2, T1, T2, T3 | M5 | 8 - 6 | 8 - 14 | 22.1 (2.5) | | | | | | |
| | | | ⊕ | M6 | 10 - 6 | 5.5 - 14 | | 45.1 (5.1) | | | | |
| | 5018 5022 | L1, L2, L3, ⊖, ⊕ 1, B1, B2, T1, T2, T3 | M6 | 8 - 6 | 8 - 14 | 45.1 (5.1) | | | | | | |
| | | | ⊕ | † | 10 - 6 | 5.5 - 14 | | 20 (2.3) | | | | |
| | 5030 | L1, L2, L3, ⊖, ⊕ 1, T1, T2, T3 | M8 | 6 - 1/0 | 14 - 50 | 90.3 (10.3) | | | | | | |
| | | | | | | | | ⊕ | † | 8 - 2 | 8 - 30 | 20 (2.3) |
| | | | | | | | | l ₁ , l ₂ | M4 | 14 - 10 | 2 - 5.5 | 12.4 (1.4) |
| | 5037 | L1, L2, L3, ⊖, ⊕ 1, T1, T2, T3 | M8 | 4 - 1/0 | 22 - 50 | 90.3 (10.3) | | | | | | |
| | | | | | | | | ⊕ | † | 8 - 2 | 8 - 30 | 20 (2.3) |
| | | | | | | | | l ₁ , l ₂ | M4 | 14 - 10 | 2 - 5.5 | 12.4 (1.4) |
| | 5045 | L1, L2, L3, ⊖, ⊕ 1, T1, T2, T3 | M8 | 3 - 1/0 | 30 - 50 | 90.3 (10.3) | | | | | | |
| | | | | | | | | ⊕ | † | 8 - 2 | 8 - 30 | 20 (2.3) |
| | | | | | | | | l ₁ , l ₂ | M4 | 14 - 10 | 2 - 5.5 | 12.4 (1.4) |
| | 5055 | L1, L2, L3, ⊖, ⊕ 1, T1, T2, T3 | M8 | 2 - 1/0 | 30 - 50 | 90.3 (10.3) | | | | | | |
| ⊕ | | | | | | | † | 6 - 2 | 22 - 30 | 20 (2.3) | | |
| l ₁ , l ₂ | | | | | | | M4 | 14 - 10 | 2 - 5.5 | 12.4 (1.4) | | |
| 5075 | L1, L2, L3, ⊖, ⊕ 1, T1, T2, T3 | M8 | 2/0 - 1/0 | 50 - 60 | 90.3 (10.3) | | | | | | | |
| | | | | | | ⊕ | † | 4 - 2 | 22 - 30 | 20 (2.3) | | |
| | | | | | | l ₁ , l ₂ | M4 | 14 - 10 | 2 - 5.5 | 12.4 (1.4) | | |
| 5090 | L1, L2, L3, ⊖, ⊕ 1, T1, T2, T3 | M10 | 3/0 - 300 | 80 - 150 | 203.6 (23) | | | | | | | |
| | | | | | | ⊕ | † | 4 - 2/0 | 22 - 60 | 20 (2.3) | | |
| | | | | | | l ₁ , l ₂ | M4 | 14 - 10 | 2 - 5.5 | 12.4 (1.4) | | |
| 5110 | L1, L2, L3, ⊖, ⊕ 1, T1, T2, T3 | M12 | 300-400 | 150 - 200 | 349.6 (39.5) | | | | | | | |
| | | | | | | ⊕ | † | 4 - 2/0 | 22 - 60 | 20 (2.3) | | |
| | | | | | | l ₁ , l ₂ | M4 | 14 - 10 | 2 - 5.5 | 12.4 (1.4) | | |
| 5160 | L1, L2, L3, ⊖, ⊕ 1, T1, T2, T3 | M12 | 350-400 | 180 - 200 | 349.6 (39.5) | | | | | | | |
| | | | | | | ⊕ | † | 3 - 2/0 | 30 - 60 | 20 (2.3) | | |
| | | | | | | l ₁ , l ₂ | M4 | 14 - 10 | 2 - 5.5 | 12.4 (1.4) | | |
| Control | Common to all models | 1-33 | M3.5 | 20 - 16 | Stranded 0.5 - 1.25 Solid 0.5 - 1.25 | - | Twisted shielded wire with Class 1 wiring | | | | | |
| | | G | | | | | | 20 - 14 | 0.5 - 2 | 8.9 (1.0) | | |

* Wire sizes are based on 75°C copper wire. † Indicates terminal uses a pressure lug.

Wire and Terminal Screw Sizes (continued)

JST Closed Loop Connectors

| Wire Size * | | Terminal Screw | JST Closed-Loop Connectors (Lugs) | Max. Torque lb-in (N·m) |
|-------------|-----------------|----------------|-----------------------------------|----------------------------|
| AWG | mm ² | | | |
| 20 | 0.5 | M3.5 | 1.25 - 3.5 | 8.9 (1.0) |
| | | M4 | 1.25 - 4 | 12.4 (1.4) |
| 18 | 0.75 | M3.5 | 1.25 - 3.5 | 8.9 (1.0) |
| | | M4 | 1.25 - 4 | 12.4 (1.4) |
| 16 | 1.25 | M3.5 | 1.25 - 3.5 | 8.9 (1.0) |
| | | M4 | 1.25 - 4 | 12.4 (1.4) |
| 14 | 2 | M3.5 | 2 - 3.5 | 8.9 (1.0) |
| | | M4 | 2 - 4 | 12.4 (1.4) |
| | | M5 | 2 - 5 | 22.1 (2.5) |
| | | M6 | 2 - 6 | 45.1 (5.1) |
| | | M8 | 2 - 8 | 90.3 (10.2) |
| 12 - 10 | 3.5 - 5.5 | M4 | 5.5 - 4 | 12.4 (1.4) |
| | | M5 | 5.5 - 5 | 22.1 (2.5) |
| | | M6 | 5.5 - 6 | 45.1 (5.1) |
| | | M8 | 5.5 - 8 | 90.3 (10.2) |
| 8 | 8 | M5 | 8 - 5 | 22.1 (2.5) |
| | | M6 | 8 - 6 | 45.1 (5.1) |
| | | M8 | 8 - 8 | 90.3 (10.2) |
| 6 | 14 | M6 | 14 - 6 | 45.1 (5.1) |
| | | M8 | 14 - 8 | 90.3 (10.2) |
| 4 | 22 | M6 | 22 - 6 | 45.1 (5.1) |
| | | M8 | 22 - 8 | 90.3 (10.2) |
| 3 - 2 | 30 - 38 | M8 | 38 - 8 | 90.3 (10.2) |
| 1 - 1/0 | 50 - 60 | M8 | 60 - 8 | 90.3 (10.2) |
| | | M10 | 60 - 10 | 203.6 (23.0) |
| 3/0 | 80 | M10 | 80 - 10 | 203.6 (23.0) |
| 4/0 | 100 | | 100 - 10 | 203.6 (23.0) |
| 4/0 | 100 | M12 | 100 - 12 | 349.6 (39.5) |
| 300MCM | 150 | | 150 - 12 | 349.6 (39.5) |
| 400MCM | 200 | | 200 - 12 | 349.6 (39.5) |
| 650MCM | 325 | M12 x 2 | 325 - 12 | 349.6 (39.5) |
| | | M16 | 325 - 16 | 867.4 (98.0) |

Note 1:

The use of a JST closed-loop connector (lug) is recommended to maintain proper clearances. Please contact your Anyhertz representative for more information.

Note 2:

Voltage drop should be considered when determining wire size. Voltage drop can be calculated using the following equation:

Phase-to phase voltage drop (V)

$$= \text{wire resistance (} \Omega \text{ /km)} \times \text{wiring distance (m)} \times \text{current (A)} \times 10^{-3}$$

Select a wire size so that voltage drop will be less than 2% of the normal rated voltage.

Control Circuit Wiring

The table below outlines the functions of the control circuit terminals.

Control Circuit Terminals

| Classification | Terminal | Signal Function | Description | Signal Level | |
|------------------------|----------|--|--|---|---|
| Sequence Input Signal | 1 | Forward run/stop | Forward run when closed, stop when open (2-wire) | Photo-coupler insulated Input: +24VDC, 8mA | |
| | 2 | Reverse run/stop | Reverse run when closed, stop when open (2-wire) | | |
| | 3 | External fault input | Fault when closed, normal state when open | | |
| | 4 | Fault reset input | Reset when closed | | |
| | 5 | Master/Aux. change Multi-step speed ref.1) | Aux. freq. ref. when closed | | |
| | 6 | Multi-step speed ref.2 | Effective when closed | | |
| | 7 | Jog reference | Jog run when closed | | |
| | 8 | External baseblock | Inv. output baseblocked when closed | | |
| | 11 | Sequence control input common | — | | |
| Analog Input Signal | 15 | +15V Power supply output | For analog command +15V power supply | +15V (Allowable current) | |
| | 33 | -15V Power supply output | For analog command -15V power supply | -15V (Allowable current) | |
| | 13 | Master frequency ref. (voltage) | -10 to +10V/-100% to +100% 0 to +10V/100% | -10 to +10V (20k Ω), 0 to +10V/(20k Ω) | |
| | 14 | Master frequency ref. (current) | 4 to 20mA/100%. | Multi-function analog input (H3-08, H3-09, H3-10, H3-11) 4 to 20mA (250 Ω) | |
| | 16 | Multi-function analog input | -10 to +10V/-100% to +100% 0 to +10 V/100% | Multi-function analog input (H3-04, H3-05, H3-06, H3-07) -10 to +10V (20k Ω), 0 to +10V/(20k Ω) | |
| | 17 | Common terminal for | 0V | — | |
| | 12 | Connection to shield sheath of signal lead | — | — | |
| Sequence Output Signal | 9 | During running (NO contact) | Closed when running | Multi-function output (H2-01 to H2-03) Dry contact Contact capacity: 250VAC, 1A or less 30VDC, 1A or less | |
| | 10 | | | | |
| | 25 | Zero speed detection | Activates at min. freq. (E1-09) or less | Open collector output 48V, 50mA or less | |
| | 26 | Speed agree detection | Activates when the freq. reaches to ± 1 Hz of set freq. | | |
| | 27 | Open collector output common | | | — |
| | 18 | Fault contact output (NO/NC contact) | When faulted closed between terminals 18 and 20 When faulted open between terminals 19 and 20 | | Dry contact Contact capacity: 250VAC, 1A or less 30VDC, 1A or less |
| 19 | | | | | |
| 20 | | | | | |
| Analog Output Signal | 21 | Frequency meter output | 0 to ± 10 V/100% frequency | Multi-function analog monitor 1 (H4-01, H4-02, H4-03) 0 to ± 11 V Max. $\pm 5\%$ 2mA or less | |
| | 22 | Common | | | |
| | 23 | Current monitor | 5V/inverter rated current | — | |

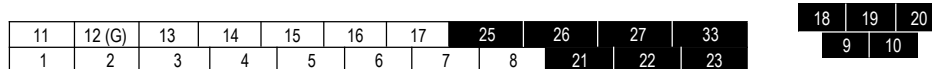

Figure 13 Control Circuit Terminal Arrangement

CHAPTER 2 OPERATION

WARNING

Precautions

- 1) Only turn ON the input power supply after replacing the front cover. Do not remove the cover while the inverter is powered up.
- 2) When the retry function (parameter L5-02) is selected, do not approach the inverter or the load, since it may restart suddenly after being stopped.
- 3) Since the Stop key can be disabled by a function setting, install a separate emergency stop switch to remove input power from the inverter.
- 4) Do not touch the heatsink or braking resistor, due to very high temperatures.
- 5) Since it is very easy to change operation speed from low to high speed, verify the safe working range of the motor and machine before operation. Also, verify the parameter settings prior to operation.
- 6) Install a separate holding brake, if necessary.
- 7) Do not check signals during operation.
- 8) All inverter parameters have been preset at the factory. Do not change the settings unless it is required.

Failure to observe these precautions may result in equipment damage, serious personal injury or death

2.1 TRIAL OPERATION

To ensure safety, prior to initial operation, disconnect the machine coupling so that the motor is isolated from the machine. If initial operation must be performed while the motor is still coupled to the machine, use great care to avoid potentially hazardous conditions. Check the following items before a trial run:

- Wiring and terminal connections are proper.
- Wire clippings and other debris removed from the unit.
- Screws are securely tightened.
- Motor is securely mounted.
- All items are correctly grounded.

Digital Operator Display at Power-Up

When the system is ready for operation, turn ON the power supply. Verify that the inverter powers up properly. If any problems are detected, turn OFF the power supply immediately. The digital operator display illuminates as shown below when the power supply is turned ON.

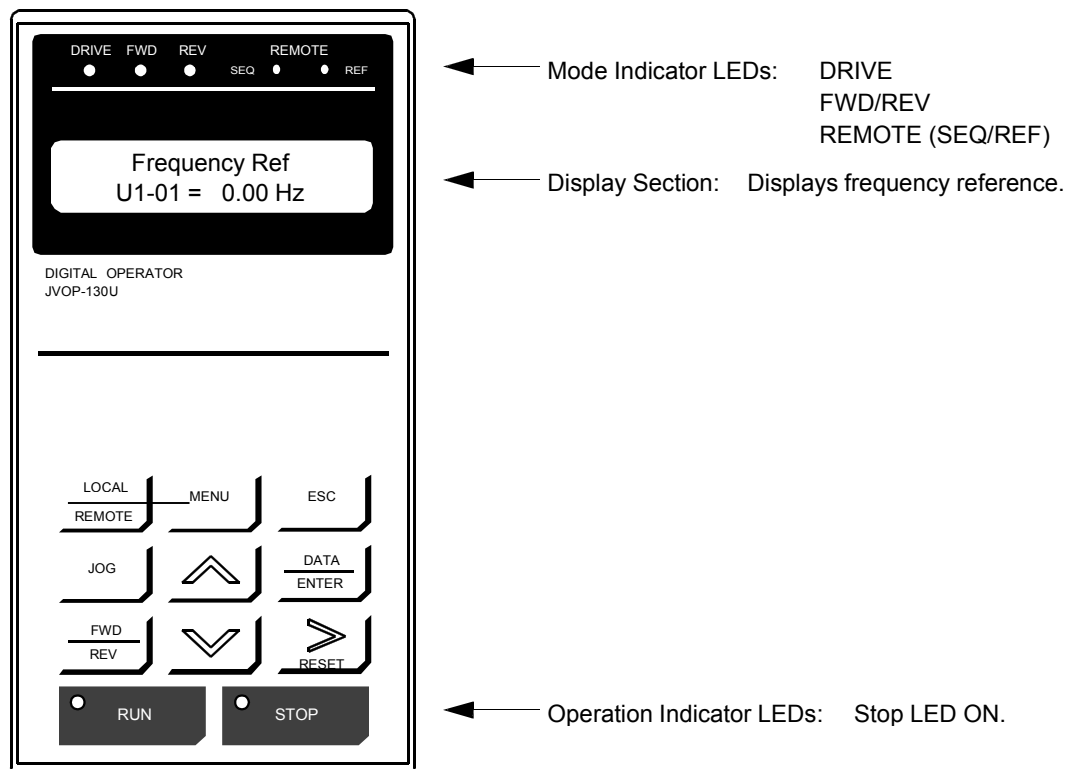

Figure 14 Digital Operator Display at Power-up

Operation Checkpoints:

- Motor rotates smoothly.
- Motor rotates in the correct direction.
- Motor has no abnormal vibration nor noise.
- Acceleration and deceleration are smooth.
- Unit is not overloaded.
- Status indicator LEDs and digital operator display are correct.

Operation by Digital Operator

The diagram below shows a typical operation profile using the digital operator.

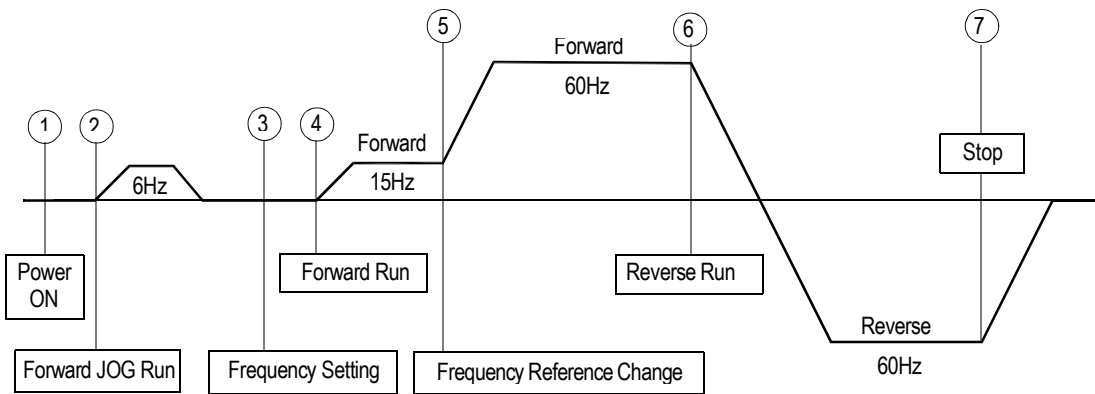







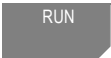









Figure 15 Operation Sequence by Digital Operator

Typical Operation Example by Digital Operator

| Description | Key Sequence | Digital Operator Display |
|--|---|---|
| <p>↑ Power ON</p> <ul style="list-style-type: none"> · Displays frequency reference value. | | <div style="border: 1px solid black; padding: 5px; width: fit-content; margin: 0 auto;"> Frequency Ref U1-01 = 0.00 Hz </div> |
| <p>↓ Operation Condition Setting</p> <ul style="list-style-type: none"> · Select LOCAL mode. |  | <p>REMOTE LED (SEQ, REF) OFF</p> |
| <p>↘ Forward Jog Run (6Hz)</p> <ul style="list-style-type: none"> · JOG run procedure (Runs while depressing JOG key.) |  | |
| <p>↔ Frequency Setting</p> <ul style="list-style-type: none"> · Change frequency reference value. Digit to be changed blinks. · Write-in set value. · Select output frequency monitor display. |  <p>Change the value by depressing</p>     | <div style="border: 1px solid black; padding: 5px; width: fit-content; margin: 0 auto;"> Frequency Ref 0 00.00 Hz </div> <div style="border: 1px solid black; padding: 5px; width: fit-content; margin: 0 auto;"> Frequency Ref 01 5 .00 Hz </div> <div style="border: 1px solid black; padding: 5px; width: fit-content; margin: 0 auto;"> Entry Accepted </div> <div style="border: 1px solid black; padding: 5px; width: fit-content; margin: 0 auto;"> Frequency Ref 01 5 .00 Hz </div> <div style="border: 1px solid black; padding: 5px; width: fit-content; margin: 0 auto;"> Output Freq U1-02 = 0.00 Hz </div> |
| <p>→ Forward Run</p> <ul style="list-style-type: none"> · Forward run (15Hz) Run & FWD LEDs light. |  | <div style="border: 1px solid black; padding: 5px; width: fit-content; margin: 0 auto;"> Output Freq U1-02 = 15.00 Hz </div> |
| <p>↕ Frequency Reference Value Change (15~60Hz)</p> <ul style="list-style-type: none"> · Select frequency reference value display · Change set value. · Write-in set value. · Select output frequency monitor display. |   <p>Depress twice.</p> <p>Change the value by depressing</p>     | <div style="border: 1px solid black; padding: 5px; width: fit-content; margin: 0 auto;"> Frequency Ref 0 15.00 Hz </div> <div style="border: 1px solid black; padding: 5px; width: fit-content; margin: 0 auto;"> Frequency Ref 06 0 .00 Hz </div> <div style="border: 1px solid black; padding: 5px; width: fit-content; margin: 0 auto;"> Entry Accepted </div> <div style="border: 1px solid black; padding: 5px; width: fit-content; margin: 0 auto;"> Output Freq U1-02 = 60.00 Hz </div> |
| <p>← Reverse Run</p> <ul style="list-style-type: none"> · Select reverse run. REV LED lights. |  | <div style="border: 1px solid black; padding: 5px; width: fit-content; margin: 0 auto;"> Output Freq U1-02 = -60.00 Hz </div> |
| <p>↘ Stop</p> <ul style="list-style-type: none"> · Decelerates to stop. Stop LED lights. |  | <div style="border: 1px solid black; padding: 5px; width: fit-content; margin: 0 auto;"> Output Freq U1-02 = 0.00 Hz </div> |

Operation by Control Circuit Terminal Signal

The diagram below shows a typical operation profile using the control circuit terminal signals.

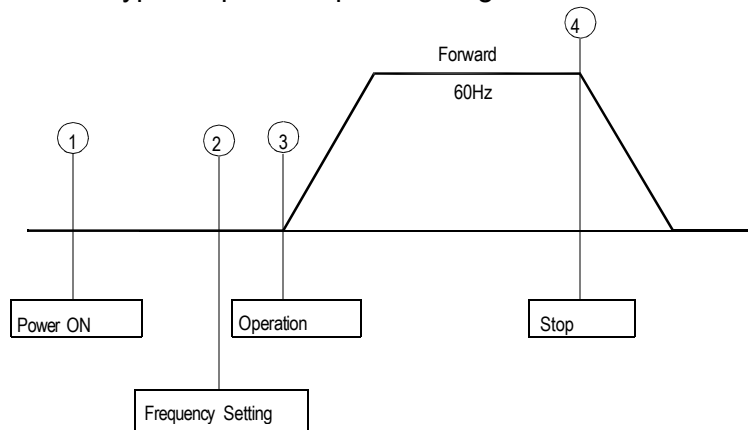

Figure 16 Operation Sequence by Control Circuit Terminal Signal

Typical Operation Example by Control Circuit Terminal Signal

| Description | Key Sequence | Digital Operator Display |
|--|--------------|--|
| <p>⏻ Power ON</p> <ul style="list-style-type: none"> · Displays frequency reference value. REMOTE mode is preset at the factory. | | <div style="border: 1px solid black; padding: 5px; margin-bottom: 5px;"> Frequency Ref U1-01 = 0.00 Hz REMOTE LED (SEQ, REF) ON </div> |
| <p>↔ Output Frequency Display</p> <ul style="list-style-type: none"> · Switch to output frequency display. | | <div style="border: 1px solid black; padding: 5px; margin-bottom: 5px;"> Output Freq U1-02 = 0.00 Hz </div> |
| <p>⏻ Forward Jog Run (6Hz)</p> <ul style="list-style-type: none"> · Close between control circuit terminals 1 & 11, and 7 & 11 closed to perform JOG run. Run & FWD LEDs illuminate. · Open between terminals 1 & 11, and 7 & 11 after verifying JOG operation | | <div style="border: 1px solid black; padding: 5px; margin-bottom: 5px;"> Output Freq U1-02 = 6.00 Hz </div> |
| <p>⏻ Frequency Setting</p> <ul style="list-style-type: none"> · Input frequency reference via terminal 13 (voltage) or 14 (voltage/current) and verify the input value with the digital operator. | | <div style="border: 1px solid black; padding: 5px; margin-bottom: 5px;"> Frequency Ref U1-01 = 60.00 Hz </div> |
| <p>↔ Output Frequency Display</p> <ul style="list-style-type: none"> · Select output frequency monitor display. | | <div style="border: 1px solid black; padding: 5px; margin-bottom: 5px;"> Output Freq U1-02 = 0.00 Hz </div> |
| <p>⏻ Forward Run</p> <ul style="list-style-type: none"> · Close between terminals 1 & 11 to perform forward run. | | <div style="border: 1px solid black; padding: 5px; margin-bottom: 5px;"> Output Freq U1-02 = 60.00 Hz </div> |
| <p>⏻ Stop</p> <ul style="list-style-type: none"> · Open between terminals 1 & 11 to stop operation. Stop LED illuminates. | | <div style="border: 1px solid black; padding: 5px; margin-bottom: 5px;"> Output Freq U1-02 = 0.00 Hz </div> |

2.2 DIGITAL OPERATOR DISPLAY

All functions of the FST-800 Drive are accessed using the digital operator. Below are descriptions of the display and keypad sections.

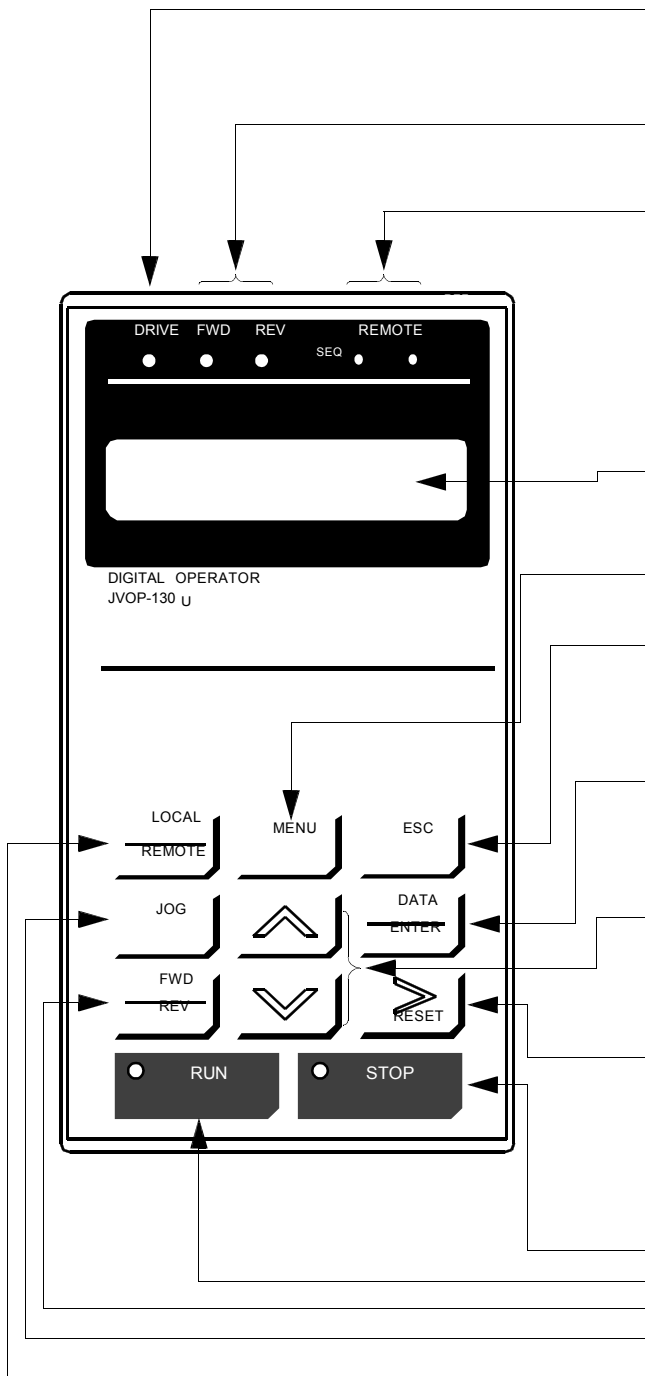

Mode Indicator LEDs

Drive Mode LED

Illuminates when selecting drive mode (operation via external terminals is possible).
OFF when selecting any other mode.

Rotation Direction LEDs

FWD: Illuminates at forward command.
REV: Illuminates at reverse command.

Remote Mode LEDs

Illuminates when selecting input mode from the control circuit terminal or serial communication.

SEQ: Illuminates when selecting run command from the control circuit terminal or serial communication.

REF: Illuminates when selecting frequency reference from the control circuit terminals 13, 14, or 16, or serial communication.

Display

Displays set values of parameters or monitoring values such as output frequency and current (2 lines x 16 characters).

Menu Key

Displays the main menu for mode selection.

Escape Key

Returns display to the previous status, before [DATA/ENTER] key was depressed. Returns menu to previous layer (i.e. function, group, mode).

Data/Enter Key

Selects mode, group, function or parameter. Displays each parameter's set value. By depressing this key (after changing a parameter setting), the set value is entered.

Menu/Value Change Keys

Selects mode, group, function, parameter or set value.

: Increment key

: Decrement key

Digit Selection Key

Selects a digit of a set value to be changed. The selected digit blinks. Resets operation at faults.

Operation Command Keys

Operation command keys operate the inverter. These are enabled only in the drive mode.

STOP: Red LED illuminates after depressing STOP key.

RUN: Red LED illuminates after depressing RUN key.

FWD/REV: Selects forward or reverse run.

JOG: Jog run is enabled while depressing this key.

Operation Mode Selection Key

Alternate between REMOTE and LOCAL (digital operator) operation.

Figure 17 Digital Operator Display at Power-up

2.3 OPERATION MODE SELECTION

The FST-800 Drive has two operation modes: LOCAL and REMOTE (see table below for description). These two modes can be selected by the digital operator “LOCAL/REMOTE” key or a multi-function input terminal command only when operation is stopped. The operation mode selected can be verified by observing the SEQ and REF LEDs on the digital operator (as shown below). The operation mode is set to REMOTE (run by control circuit terminals 13 and/or 14 frequency reference and run command from control circuit terminals) prior to shipment. Multi-function contact inputs from control circuit terminals 3 to 8 are enabled in both operation modes.

- LOCAL: Both frequency reference and run command are set by the digital operator. SEQ and REF LEDs go OFF.
- REMOTE: Master frequency reference and run command can be selected as described in the table below.

Operation Mode Selection

| Setting | Reference Selection (B1-01) | REF LED | Operation Method Selection (B1-02) | SEQ LED |
|---------|---|----------|--|----------|
| 0 | Master frequency reference from digital operator | OFF | Operation by run command from digital operator | OFF |
| 1 | Master frequency reference from control circuit terminals 13 and 14 | ON | Operation by run command from control circuit terminal | ON |
| 2 | Master frequency reference set by serial communication | blinking | Operation by run command from serial communication | blinking |
| 3 | Master frequency reference set by option card | blinking | Operation by run command from option card | blinking |
| 4 | Master frequency reference set by EWS (Engineering Work Station). This setting will be used with the CP-717 <1110>. | ON | Operation by run command from EWS (CP-717) <1110>. | ON |

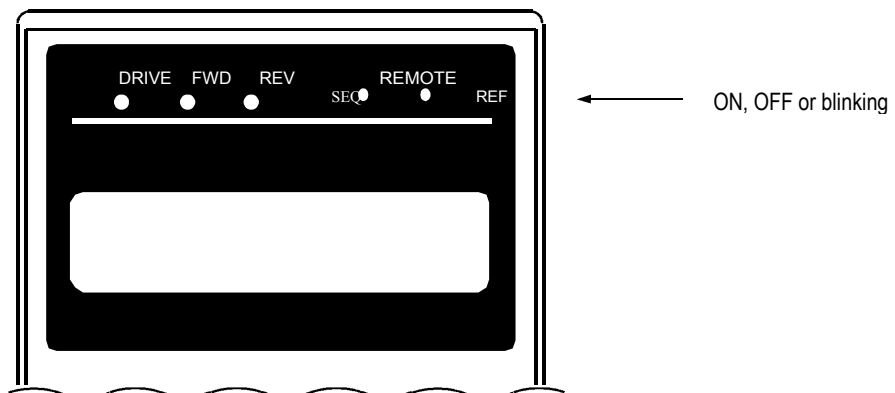

Figure 18 Operation Mode LEDs

CHAPTER 3 QUICK-START PROGRAMMING

Quick-Start Parameter Sequence

| Main Menu * | Key Press | Function | Parameter No. |
|--------------------|----------------------------|----------------------------------|---------------|
| Operation | | Frequency Reference | U1-01 |
| | | Output Frequency | U1-02 |
| | | Output Current | U1-03 |
| | | Output Voltage | U1-06 |
| | DATA/ENTER | U2 Fault Trace /U2-01 to U2-14 | U2 |
| | DATA/ENTER | U3 Fault History /U3-01 to U3-08 | U3 |
| | DATA/ENTER | U1 Monitor /U1-01 to U1-14 | U1 |
| Initialize | ESC DATA/ENTER | Select Language | A1-00 |
| | | Access Level | A1-01 |
| | | Control Method | A1-02 |
| | | Initialize Parameters | A1-03 |
| | | Enter Password | A1-04 |
| Programming | ESC DATA/ENTER | Reference Source | B1-01 |
| | | Run Source | B1-02 |
| | | Stopping Method | B1-03 |
| | | Acceleration Time 1 | C1-01 |
| | | Deceleration Time 1 | C1-02 |
| | | Preset Frequency Reference 1 | D1-01 |
| | | Preset Frequency Reference 2 | D1-02 |
| | | Preset Frequency Reference 3 | D1-03 |
| | | Preset Frequency Reference 4 | D1-04 |
| | | Jog Frequency Reference | D1-09 |
| | | Input Voltage | E1-01 |
| | | Motor Selection | E1-02 |
| | | V/f Pattern Selection | E1-03 |
| | | Maximum Frequency | E1-04 |
| | | Maximum Voltage | E1-05 |
| | | Maximum Voltage Output Frequency | E1-06 |
| | | Middle Output Frequency | E1-07 |
| | | Middle Output Voltage | E1-08 |
| | | Minimum Output Frequency | E1-09 |
| | | Minimum Output Voltage | E1-10 |
| | Base Voltage | E1-13 | |
| | Motor Rated Current | E2-01 | |
| | Motor Rated Slip Frequency | E2-02 | |
| | Motor No-Load Current | E2-03 | |
| | Number of Motor Poles | E2-04 | |
| Auto-Tuning | ESC DATA/ENTER | Rated Voltage | -- |
| | | Rated Current | -- |
| | | Rated Frequency | -- |
| | | Rated Speed | -- |
| | | Number of Poles | -- |
| | Select Motor 1 or 2 | -- | |
| Modified Constants | ESC DATA/ENTER | | -- |

* Depress the Menu key on the digital operator to return to **Main Menu: Operation**.

The FST-800 Series ships preset to open loop vector control, quick-start access level. Included in this section are descriptions of the Quick-Start parameters, for simplified operation of this drive.

3.1 Main Menu: Initialize <ENTER>

A1-00 Language Selection

Select Language

| | | | |
|-------------|-----------|------------------|-------------|
| V/f Control | V/f w/ PG | Open Loop Vector | Flux Vector |
| | | | |

The FST-800 series software incorporates seven display languages. Select the language displayed on the digital operator according to the following table:

| Setting | Description |
|---------|------------------------------------|
| 0 | English (<i>factory default</i>) |
| 1 | Traditional Chinese |
| 2 | Simplified Chinese |
| 3 | German |
| 4 | French |
| 5 | Russian |
| 6 | Spanish |

A1-01 Parameter Access Level

Access Level

| | | | |
|-------------|-----------|------------------|-------------|
| V/f Control | V/f w/ PG | Open Loop Vector | Flux Vector |
| | | | |

This parameter determines the group of parameters that can be accessed during set-up/programming. There are five access levels ranging from parameters for viewing only (0: Operation Only), to parameters required for advanced applications (4: Advanced Level). The inverter defaults to a setting of “2: Quick Start” to aid in simplifying set-up. See the following table:

| Setting | Description |
|---------|--|
| 0 | Operation Only |
| 1 | User Program - Accesses parameters selected by OEM. |
| 2 | Quick Start Level (<i>factory default</i>) - For maintenance-level |
| 3 | Basic Level - For basic programming in most applications. |
| 4 | Advanced Level - For advanced programming in special |

A1-02 Control Method Selection

Control Method

| | | | |
|-------------|-----------|------------------|-------------|
| V/f Control | V/f w/ PG | Open Loop Vector | Flux Vector |
| | | | |

Select the control method best suited for your application.

| Setting | Description |
|---------|---|
| 0 | V/f Control - For general-purpose and multiple motor applications. |
| 1 | V/f with PG Feedback - For general-purpose applications requiring closed loop speed control. |
| 2 | Open Loop Vector (<i>factory default</i>) - For applications requiring open loop speed control, higher torque at low speeds (150% |
| 3 | Flux Vector - For applications requiring precise speed and torque control, includ- ing zero speed control. Uses encoder feedback. |

A1-03 Operator Status

Init Parameters

| | | | |
|-------------|-----------|------------------|-------------|
| V/f Control | V/f w/ PG | Open Loop Vector | Flux Vector |
| | | | |

Use this parameter to re-initialize the inverter to its factory default settings. It is also possible to re-initialize the inverter to settings as determined by the user. See the FST-800 Programming Manual for further details on the user initialization.

| Setting | Description |
|---------|--|
| 0 | No Initialization (<i>factory default</i>) |
| 1110 | User Initialization |
| 2220 | 2-Wire Initialization |
| 3330 | 3-Wire Initialization |

A1-04 Password Entry

Enter Password

| | | | |
|-------------|-----------|------------------|-------------|
| V/f Control | V/f w/ PG | Open Loop Vector | Flux Vector |
| | | | |

This parameter allows the password lock-out of users from prohibited parameters. This parameter is used in conjunction with Function A2, the user parameters group. When the “user program” access level is selected and the programming is locked via the A1-04 password, only those parameters in group A1 and A2 can be accessed. All other parameters cannot be viewed.

3.2 Main Menu: Programming <ENTER>

| | | |
|--------------|--------------------------------------|-------------------------|
| <i>B1-01</i> | <i>Frequency Reference Selection</i> | <i>Reference Source</i> |
| <i>B1-02</i> | <i>Operation Method Selection</i> | <i>Run Source</i> |

| | | | |
|-------------|-----------|------------------|-------------|
| V/f Control | V/f w/ PG | Open Loop Vector | Flux Vector |
| | | | |

B1-01 and B1-02 determine how the inverter is to receive a frequency reference and a start/stop command, respectively. Frequency reference and run command can be set independently as shown below:

| Setting | Description |
|----------|--|
| 0 | Command from digital operator |
| 1 | Command from control circuit terminal (<i>factory default</i>) |
| 2 | Command from serial communication |
| 3 | Command from option card |
| 4 | Engineering Workstation (EWS) - For use with CP-717 <1110> |

By depressing the LOCAL/REMOTE key on the digital operator, the operation mode can be selected as shown below:

Local: → Operation according to frequency reference and run command from digital operator. Remote: Operation according to frequency reference and run command set by *B1-01* & *B1-02*.

The digital operator is reset to remote operation when power is cycled.

| | | | |
|-------------|-----------|------------------|-------------|
| V/f Control | V/f w/ PG | Open Loop Vector | Flux Vector |
| | | | |

B1-03 Stopping Method Selection

Stopping Method

This function selects the stopping method suitable for the particular application.

| Setting | Description |
|---------|---|
| 0 | Deceleration to stop (<i>factory default</i>) |
| 1 | Coast to stop |
| 2 | DC injection to stop |
| 3 | Coast to stop with timer |

- Deceleration to Stop (*B1-03 = "0"*)

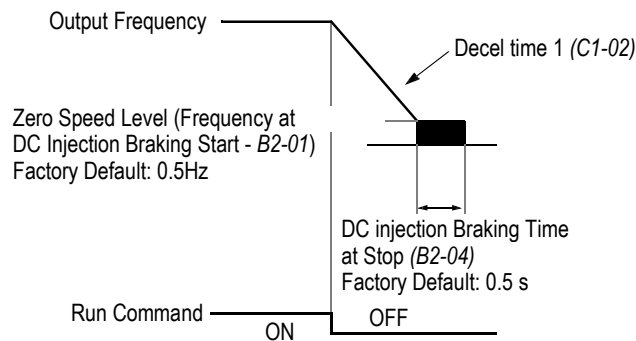

Figure 19 Stopping Method - Deceleration to Stop

Upon removal of the FWD (REV) run command, the motor decelerates at a deceleration rate determined by the time set in deceleration time 1 (*C1-02*) and DC injection braking is applied immediately before stop. If the deceleration time is short or the load inertia is large, an overvoltage fault (OV) may occur during deceleration. In this case, increase the deceleration time or install an optional braking resistor/unit.

Braking torque: without braking resistor, approx. 20% of motor rated torque with braking resistor, approx. 150% of motor rated torque

- Coast to Stop (*B1-03 = "1"*)

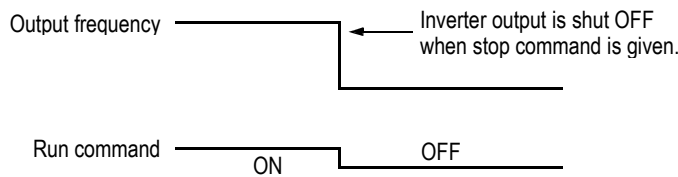

Figure 20 Stopping Method - Coast to Stop

Upon removal of the FWD (REV) run command, the motor coasts. After a stop command is given, a run command can be accepted, but operation does not start until after the minimum baseblock time (*L2-03*) elapses.

· DC Injection Braking Stop ($B1-03 = "2"$)

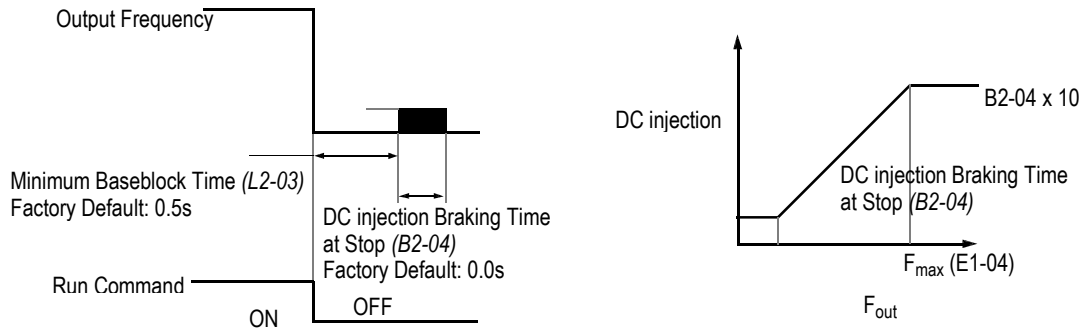

Figure 21 Stopping Method - DC Injection Braking Stop

Upon removal of the FWD (REV) run command, the motor brakes to stop, according to the DC injection braking time at stop set in $B2-04$. If this value is set to "0" (*factory default*), DC injection braking is disabled, and the motor coasts to stop. When choosing this function, note that the actual stop time from maximum frequency is the time set in $B2-04$ multiplied by 10 (see the figure above). This stopping method is disabled during flux vector control.

· Coast to Stop with Timer 1 ($B1-03 = "3"$)

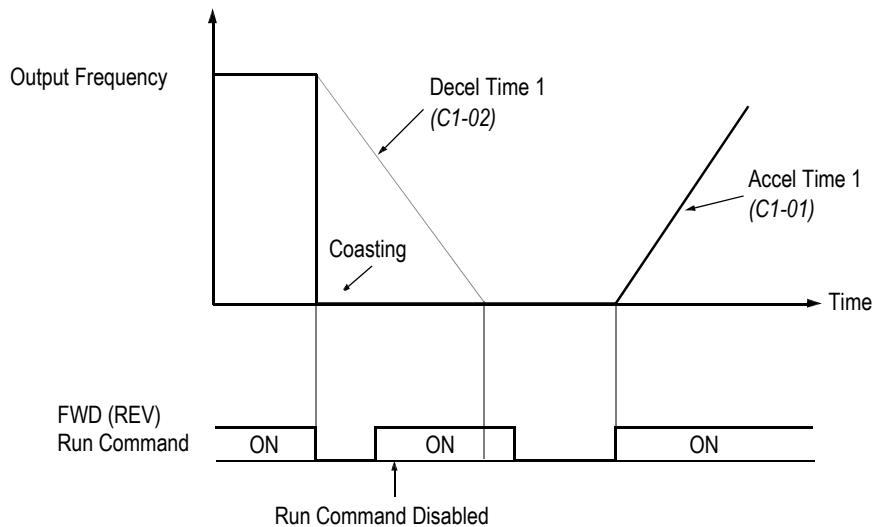

Figure 22 Stopping Method - Coast to Stop w/ Timer

After a stop command is given, a run command is not accepted while the coast to stop timer $C1-02$ elapses (same as Decel Time 1). After the timer runs out, another run command must be given for the inverter to begin acceleration. This stopping method is disabled during flux vector control.

CI-01 Acceleration time 1

Accel Time 1

CI-02 Deceleration time 1

Decel Time 1

Setting Range: 0.00 to 6000.0s

Factory Default: 10.0s

| V/f Control | V/f w/ PG | Open Loop Vector | Flux Vector |
|-------------|-----------|------------------|-------------|
| | | | |
| | | | |

Acceleration time 1 sets the time necessary for the output frequency to accelerate from 0Hz to maximum output frequency as set in parameter E1-04. Deceleration time 1 sets the time necessary for the output frequency to decelerate from the maximum output frequency to 0Hz.

DI-01 Preset Frequency Reference 1

Reference 1

DI-02 Preset Frequency Reference 2

Reference 2

DI-03 Preset Frequency Reference 3

Reference 3

DI-04 Preset Frequency Reference 4

Reference 4

Setting Range: 0.0 to 400.0Hz

Factory Default: 0.0Hz

| V/f Control | V/f w/ PG | Open Loop Vector | Flux Vector |
|-------------|-----------|------------------|-------------|
| | | | |
| | | | |
| | | | |
| | | | |

Up to 4 preset speed references (including jog) can be set through multi-function contact input function selections in the Quick-Start mode. Terminals 6 and 7 are factory defaulted to multi-step speed inputs 1 and 2, respectively. See the following table for programming preset speed references in the Quick-Start mode.

| Terminal 5 | Terminal 6 | Speed Reference |
|------------|------------|---|
| Open | Open | Speed Reference 1 - Set Reference Source (<i>B1-01</i>) to "0". |
| Closed | Open | Speed Reference 2 (When H3-05→0 and H3-09→0) |
| Open | Closed | Speed Reference 3 |
| Closed | Closed | Speed Reference 4 |

Note: 9 preset references can be set in the Advanced modes.

DI-09 Jog Frequency Reference

JOG Reference

| V/f Control | V/f w/ PG | Open Loop Vector | Flux Vector |
|-------------|-----------|------------------|-------------|
| | | | |

The jog frequency reference can be set in this parameter. In the Quick-Start mode, depress the JOG key on the digital operator, or close terminal 7 when parameter H1-05 is set to "6", to use this function. The jog command always has priority over other reference commands. When using terminal 7 to select the jog frequency, a separate run command must be applied to run the inverter.

E1-01 Input Voltage

Input Voltage

| | | | |
|-------------|-----------|------------------|-------------|
| V/f Control | V/f w/ PG | Open Loop Vector | Flux Vector |
| | | | |

Setting Range: 155 to 255V (230V class), 310 to 510V (460V class), 445 to 733V (575V class) Factory Default: 230V, 460V, 575V

Set this parameter to the inverter input supply voltage in units of 1V. This parameter does not have to be set to the exact incoming voltage level. The nominal voltage is normally sufficient (i.e. 230V, 380V, 460V, 575V).

E1-02 Motor Selection

Motor Selection

| | | | |
|-------------|-----------|------------------|-------------|
| V/f Control | V/f w/ PG | Open Loop Vector | Flux Vector |
| | | | |

Select between fan-cooled, blower-cooled, and vector duty motor types with this parameter. This parameter sets the motor overload (OL1) protection to match typical motor characteristics. Set this parameter to “0” for standard TEFC motors, as these motors typically have a limited constant torque speed range. Set to “1” for standard blower-cooled motors with a constant torque speed range of 10:1. Set to “2” for vector duty motors which have a 100:1 or 1000:1 speed range or when full torque at zero speed is required.

| Setting | Description |
|---------|---|
| 0 | Fan-cooled motor characteristics (<i>factory default</i>) |
| 1 | Blower-cooled motor characteristics |
| 2 | Vector duty motor <1110> |

E1-03 V/f Pattern Selection

V/f Selection

| | | | |
|-------------|-----------|------------------|-------------|
| V/f Control | V/f w/ PG | Open Loop Vector | Flux Vector |
| | | | |

Choose a preset V/f pattern for operation in V/f modes only. It may be necessary to change the V/f pattern when using a high-speed motor, or when special torque adjustment is required in the application.

- Set values 0 to E: Preset V/f pattern can be selected (E1-04 through E1-13 are fixed).
- F:** Custom V/f pattern can be set (*factory default*) (E1-04 through E1-13 can be set individually).

Set the V/f pattern according to the applications described in the table on the following page:

Preset V/f Patterns

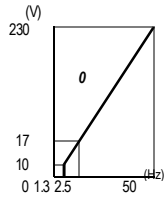
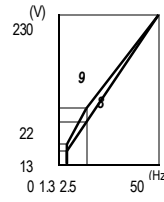
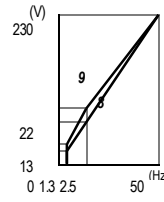
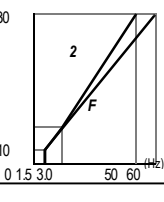
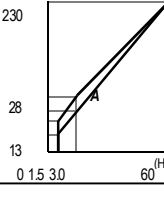
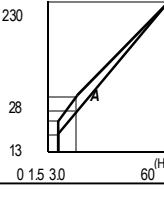
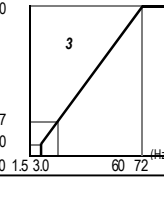
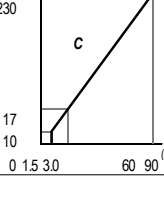
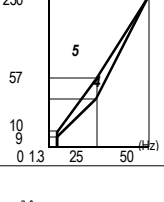
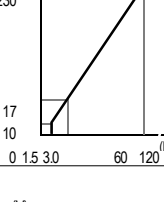
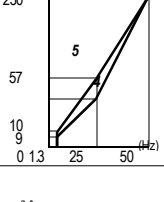
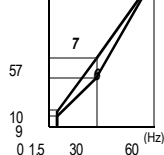
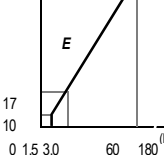
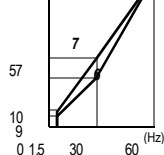
| | | Specifications | E1-03 | V/f Pattern *1 | | | Specifications | E1-03 | V/f Pattern *1 |
|-----------------|-----------------|-------------------|------------------------|---|-------------------------|-------|---|---|---|
| General-purpose | 50Hz | | 0 |  | High Starting Torque *2 | 50Hz | High Starting Torque 1 | 8 |  |
| | | | High Starting Torque 2 | 9 | | |  | | |
| | 60Hz Saturation | 1 | F |  | Starting Torque 1 | A |  | | |
| | | | | | High Torque 2 | | |  | |
| | 72Hz | | 3 |  | | 90Hz | C |  | |
| Variable Torque | 50Hz | Variable Torque 1 | 4 |  | High Speed Operation | 120Hz | D |  | |
| | | Torque 2 | 5 |  | | | | | |
| | 60Hz | Variable Torque 1 | 6 |  | | 180Hz | E |  | |
| | | Torque 2 | 7 |  | | | | | |

Notes:

*1 The following conditions must be considered when selecting a V/f pattern:

- The voltage and frequency characteristics of the motor.
- The maximum speed of the motor.

*2 Select a high starting torque V/f pattern only under the following conditions:

- The wiring distance is long - 492ft (150m) and above.
- Large voltage drop at start-up.
- AC reactor is connected to the inverter's input or output.
- A motor rated below the nominal output of the inverter is used.

*3 Voltage in preset patterns is doubled for 460V class inverters. The 575V patterns are 2.5 times as large as the 230V patterns.

Custom V/f Pattern

Set up a custom V/f pattern by setting parameter *E1-03* to “F”, and then setting the values in parameters *E1-04* to *E1-10*.

E1-04 Maximum Frequency

E1-05 Maximum Voltage

E1-06 Maximum Voltage Output Frequency

E1-07 Middle Output Frequency

E1-08 Middle Output Voltage

E1-09 Minimum Output Frequency

E1-10 Minimum Output Voltage

E1-13 Motor Base Voltage

Max Frequency

Max Voltage

Base Frequency

Mid Frequency A

Mid Voltage A

Min Frequency

Min Voltage

Base Voltage

| V/f Control | V/f w/ PG | Open Loop Vector | Flux Vector |
|-------------|-----------|------------------|-------------|
| | | | |
| | | | |
| | | | |
| | | | |
| | | | |
| | | | |
| | | | |
| | | | |
| | | | |
| | | | |

Be sure to satisfy the following conditions for setting parameters *E1-04* to *E1-10*:

E1-09 *E1-07* < *E1-06* *E1-04*

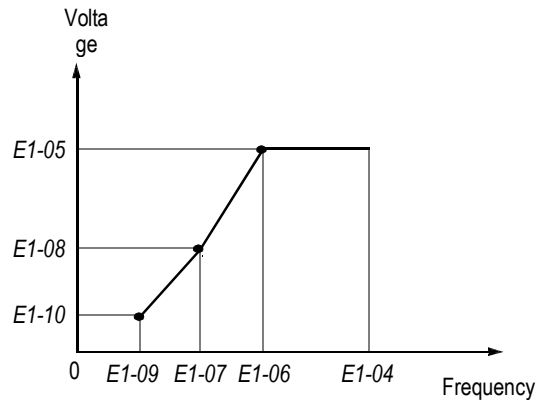

Figure 23 Custom V/f Pattern Setting

| Parameter No. | Name | Unit | Setting Range | Factory Default |
|---------------|---|--------|-----------------|-----------------|
| <i>E1-04</i> | Maximum output frequency | 0.1 Hz | 50.0 to 400 Hz | 60.0 Hz |
| <i>E1-05</i> | Maximum voltage | 0.1 V | 0.1 to 255 V * | 230 V * |
| <i>E1-06</i> | Maximum voltage output frequency (base frequency) | 0.1 Hz | 0.2 to 400 Hz | 60.0 Hz |
| <i>E1-07</i> | Mid. output frequency | 0.1 Hz | 0.1 to 399 Hz | 3.0 Hz |
| <i>E1-08</i> | Mid. output frequency voltage | 0.1 V | 0.1 to 255 V * | 17.2 V * |
| <i>E1-09</i> | Minimum output frequency | 0.1 Hz | 0.1 to 10.0 Hz | 1.5 Hz |
| <i>E1-10</i> | Minimum output frequency voltage | 0.1 V | 0.1 to 50.0 V * | 10.3 V * |

* For 460V class units, the value is twice that of 230V class units. For 575V class units the value is 2.5 times the 230V value.

Increasing the voltage in the V/f pattern increases motor torque. However, when setting a custom V/f pattern, increase the voltage gradually while monitoring the motor current, to prevent:

- Inverter fault trips as a result of motor overexcitation
- Motor overheat or excessive vibration

V/F Patterns for Inverter Capacity 0.4 ~ 1.5kW for 230V Class*

| Parameter No. | Name | Unit | Factory Setting | | | | | | | |
|---------------|-------------------------------|------|-----------------|-------|-------|-------|-------|-------|-------|-------|
| E1-03 | V/f Pattern Selection | — | 0 | 1 | 2 | 3 | 4 | 5 | 6 | 7 |
| E1-04 | Max. Output Frequency | Hz | 50.0 | 60.0 | 60.0 | 72.0 | 50.0 | 50.0 | 60.0 | 60.0 |
| E1-05 | Max. Voltage | V | 230.0 | 230.0 | 230.0 | 230.0 | 230.0 | 230.0 | 230.0 | 230.0 |
| E1-06 | Max. Voltage Frequency | Hz | 50.0 | 60.0 | 50.0 | 60.0 | 50.0 | 50.0 | 60.0 | 60.0 |
| E1-07 | Mid. Output Frequency | V | 2.5 | 3.0 | 3.0 | 3.0 | 25.0 | 25.0 | 30.0 | 30.0 |
| E1-08 | Mid. Output Frequency Voltage | V | 17.2 | 17.2 | 17.2 | 17.2 | 40.2 | 57.5 | 40.2 | 57.5 |
| E1-09 | Min. Output Frequency | Hz | 1.3 | 1.5 | 1.5 | 1.5 | 1.3 | 1.3 | 1.5 | 1.5 |
| E1-10 | Min. Output Frequency Voltage | V | 10.3 | 10.3 | 10.3 | 10.3 | 9.2 | 10.3 | 9.2 | 10.3 |

* For 460V class units, the value is twice that of 230V class units. For 575V class units the value is 2.5 times the 230V value.

V/F Patterns for Inverter Capacity 0.4 ~ 1.5kW for 230V Class* (Continued)

| Parameter No. | Name | Unit | Factory Setting | | | | | | | |
|---------------|-------------------------------|------|-----------------|-------|-------|-------|-------|-------|-------|-------|
| E1-03 | V/f Pattern Selection | — | 8 | 9 | A | B | C | D | E | F |
| E1-04 | Max. Output Frequency | Hz | 50.0 | 50.0 | 60.0 | 60.0 | 90.0 | 120.0 | 180.0 | 60.0 |
| E1-05 | Max. Voltage | V | 230.0 | 230.0 | 230.0 | 230.0 | 230.0 | 230.0 | 230.0 | 230.0 |
| E1-06 | Max. Voltage Frequency | Hz | 50.0 | 50.0 | 60.0 | 60.0 | 60.0 | 60.0 | 60.0 | 60.0 |
| E1-07 | Mid. Output Frequency | V | 2.5 | 2.5 | 3.0 | 3.0 | 3.0 | 3.0 | 3.0 | 3.0 |
| E1-08 | Mid. Output Frequency Voltage | V | 21.8 | 27.6 | 21.8 | 27.6 | 17.2 | 17.2 | 17.2 | 17.2 |
| E1-09 | Min. Output Frequency | Hz | 1.3 | 1.3 | 1.5 | 1.5 | 1.5 | 1.5 | 1.5 | 1.5 |
| E1-10 | Min. Output Frequency Voltage | V | 12.6 | 14.9 | 12.6 | 17.2 | 10.3 | 10.3 | 10.3 | 10.3 |

* For 460V class units, the value is twice that of 230V class units. For 575V class units the value is 2.5 times the 230V value.

V/F Patterns for Inverter Capacity 2.2 ~ 45kW for 230V Class*

| Parameter No. | Name | Unit | Factory setting | | | | | | | |
|---------------|-------------------------------|------|-----------------|-------|-------|-------|-------|-------|-------|-------|
| E1-03 | V/f Pattern Selection | — | 0 | 1 | 2 | 3 | 4 | 5 | 6 | 7 |
| E1-04 | Max. Output Frequency | Hz | 50.0 | 60.0 | 60.0 | 72.0 | 50.0 | 50.0 | 60.0 | 60.0 |
| E1-05 | Max. Voltage | V | 230.0 | 230.0 | 230.0 | 230.0 | 230.0 | 230.0 | 230.0 | 230.0 |
| E1-06 | Max. Voltage Frequency | Hz | 50.0 | 60.0 | 50.0 | 60.0 | 50.0 | 50.0 | 60.0 | 60.0 |
| E1-07 | Mid. Output Frequency | V | 2.5 | 3.0 | 3.0 | 3.0 | 25.0 | 25.0 | 30.0 | 30.0 |
| E1-08 | Mid. Output Frequency Voltage | V | 16.1 | 16.1 | 16.1 | 16.1 | 40.2 | 57.5 | 40.2 | 57.5 |
| E1-09 | Min. Output Frequency | Hz | 1.3 | 1.5 | 1.5 | 1.5 | 1.3 | 1.3 | 1.5 | 1.5 |
| E1-10 | Min. Output Frequency Voltage | V | 8.0 | 8.0 | 8.0 | 8.0 | 6.9 | 8.0 | 6.9 | 8.0 |

* For 460V class units, the value is twice that of 230V class units. For 575V class units the value is 2.5 times the 230V value.

V/F Patterns for Inverter Capacity 2.2 ~ 45kW for 230V Class* (Continued)

| Parameter No. | Name | Unit | Factory Setting | | | | | | | |
|---------------|-------------------------------|------|-----------------|-------|-------|-------|-------|-------|-------|-------|
| E1-03 | V/f Pattern Selection | — | 8 | 9 | A | B | C | D | E | F |
| E1-04 | Max. Output Frequency | Hz | 50.0 | 50.0 | 60.0 | 60.0 | 90.0 | 120.0 | 180.0 | 60.0 |
| E1-05 | Max. Voltage | V | 230.0 | 230.0 | 230.0 | 230.0 | 230.0 | 230.0 | 230.0 | 230.0 |
| E1-06 | Max. Voltage Frequency | Hz | 50.0 | 50.0 | 60.0 | 60.0 | 60.0 | 60.0 | 60.0 | 60.0 |
| E1-07 | Mid. Output Frequency | V | 2.5 | 2.5 | 3.0 | 3.0 | 3.0 | 3.0 | 3.0 | 3.0 |
| E1-08 | Mid. Output Frequency Voltage | V | 20.7 | 26.4 | 20.7 | 26.4 | 16.1 | 16.1 | 16.1 | 16.1 |
| E1-09 | Min. Output Frequency | Hz | 1.3 | 1.3 | 1.5 | 1.5 | 1.5 | 1.5 | 1.5 | 1.5 |
| E1-10 | Min. Output Frequency Voltage | V | 10.3 | 12.6 | 10.3 | 14.9 | 8.0 | 8.0 | 8.0 | 8.0 |

* For 460V class units, the value is twice that of 230V class units. For 575V class units the value is 2.5 times the 230V value.

V/F Patterns for Inverter Capacity 55 ~ 300kW for 230V Class*

| Parameter No. | Name | Unit | Factory Setting | | | | | | | |
|---------------|-------------------------------|------|-----------------|----------|----------|----------|----------|----------|----------|----------|
| | | | 0 | 1 | 2 | 3 | 4 | 5 | 6 | 7 |
| E1-03 | V/f Pattern Selection | – | 0 | 1 | 2 | 3 | 4 | 5 | 6 | 7 |
| E1-04 | Max. Output Frequency | Hz | 50.0<21> | 60.0 | 60.0 | 72.0<21> | 50.0<21> | 50.0<21> | 60.0 | 60.0 |
| E1-05 | Max. Voltage | V | 230.0 | 230.0 | 230.0 | 230.0 | 230.0 | 230.0 | 230.0 | 230.0 |
| E1-06 | Max. Voltage Frequency | Hz | 50.0<21> | 60.0 | 50.0<21> | 60.0 | 50.0<21> | 50.0<21> | 60.0 | 60.0 |
| E1-07 | Mid. Output Frequency | V | 2.5<21> | 3.0 | 3.0 | 3.0 | 25.0<21> | 25.0<21> | 30.0 | 30.0 |
| E1-08 | Mid. Output Frequency Voltage | V | 13.8<21> | 13.8<21> | 13.8<21> | 13.8<21> | 40.2<21> | 57.5<21> | 40.2<21> | 57.5<21> |
| E1-09 | Min. Output Frequency | Hz | 1.3<21> | 1.5 | 1.5 | 1.5 | 1.3<21> | 1.3<21> | 1.5 | 1.5 |
| E1-10 | Min. Output Frequency Voltage | V | 6.9 | 6.9 | 6.9 | 6.9 | 5.7<21> | 6.9 | 5.7<21> | 6.9 |

* For 460V class units, the value is twice that of 230V class units. For 575V class units the value is 2.5 times the 230V value.

V/F Patterns for Inverter Capacity 55 ~ 300kW for 230V Class* (Continued)

| Parameter No. | Name | Unit | Factory Setting | | | | | | | |
|---------------|-------------------------------|------|-----------------|----------|----------|----------|----------|-----------|-----------|----------|
| | | | 8 | 9 | A | B | C | D | E | F |
| E1-03 | V/f Pattern Selection | – | 8 | 9 | A | B | C | D | E | F |
| E1-04 | Max. Output Frequency | Hz | 50.0<21> | 50.0<21> | 60.0 | 60.0 | 90.0<21> | 120.0<21> | 180.0<21> | 60.0 |
| E1-05 | Max. Voltage | V | 230.0 | 230.0 | 230.0 | 230.0 | 230.0 | 230.0 | 230.0 | 230.0 |
| E1-06 | Max. Voltage Frequency | Hz | 50.0<21> | 50.0<21> | 60.0 | 60.0 | 60.0 | 60.0 | 60.0 | 60.0 |
| E1-07 | Mid. Output Frequency | V | 2.5<21> | 2.5<21> | 3.0 | 3.0 | 3.0 | 3.0 | 3.0 | 3.0 |
| E1-08 | Mid. Output Frequency Voltage | V | 17.2<21> | 23.0<21> | 17.2<21> | 23.0<21> | 13.8<21> | 13.8<21> | 13.8<21> | 13.8<21> |
| E1-09 | Min. Output Frequency | Hz | 1.3<21> | 1.3<21> | 1.5 | 1.5 | 1.5 | 1.5 | 1.5 | 1.5 |
| E1-10 | Min. Output Frequency Voltage | V | 8.0<21> | 10.3<21> | 8.0<21> | 12.6<21> | 6.9 | 6.9 | 6.9 | 6.9 |

* For 460V class units, the value is twice that of 230V class units. For 575V class units the value is 2.5 times the 230V value.

E2-01 Motor Rated Current

Motor Rated FLA

| V/f Control | V/f w/ PG | Open Loop Vector | Flux Vector |
|-------------|-----------|------------------|-------------|
| | | | |

Sets the motor rated current in units of 0.01A for inverter sizes 7.5kW and smaller; 0.1A for sizes 11kW and larger. This setting varies depending on the inverter model setting (O2-04).

E2-02 Motor Rated Slip Frequency

Motor Rated Slip

| V/f Control | V/f w/ PG | Open Loop Vector | Flux Vector |
|-------------|-----------|------------------|-------------|
| | | | |

Setting range: 0.00 to 20.00Hz

Sets the motor rated slip frequency in units of 0.01Hz. This setting varies depending on the motor. Use the following equation to calculate the motor rated slip frequency:

$$f_s = f - \frac{N \cdot P}{120}$$

where:

- f_s : slip frequency (Hz)
- f : motor rated frequency (Hz)
- N : motor rated speed (rpm)
- P : number of motor poles

E2-03 Motor No-Load Current

No-Load Current

| V/f Control | V/f w/ PG | Open Loop Vector | Flux Vector |
|-------------|-----------|------------------|-------------|
| | | | |

Sets the motor no-load current in units of 0.01A for inverter sizes 7.5kW and smaller; 0.1A for sizes 11kW and larger. This setting varies depending on the inverter model setting (O2-04).

E2-04 Number of Motor Poles

Number of Poles

| V/f Control | V/f w/ PG | Open Loop Vector | Flux Vector |
|-------------|-----------|------------------|-------------|
| | | | |

Setting Range: 2 to 48 poles
 Factory Default: 4 poles

Sets the number of motor poles.

F1-04 PG Constant

PG Pulses/Rev

| V/f Control | V/f w/ PG | Open Loop Vector | Flux Vector |
|-------------|-----------|------------------|-------------|
| | | | |

Setting Range: 0 to 60000
 Factory Default: 1024

Sets the encoder pulse count (per revolution) for the closed loop control modes (VF w/PG and Flux Vector).

3.3 Main Menu: Auto-Tuning <ENTER>

Adaptation to most motors manufactured worldwide is possible with the FST-800 Drive automatic tuning function. Available in both open loop vector and flux vector control modes, the inverter prompts the user for minimal motor information, then guides the user through a quick, simple tuning process. Below is the motor data required for automatic tuning in the quick-start mode:

| Name | Description | V/f Contro | V/f w/ | Open Loop | Flux Vecto |
|-----------------------|--|---------------|-----------|--------------|---------------|
| Motor Rated Voltage | Sets motor's rated voltage in VAC. | | | | |
| Motor Rated Current | Sets motor's rated current in A. | | | | |
| Motor Rated Frequency | Sets motor's rated frequency in Hz. | | | | |
| Motor Rated Speed | Sets motor's rated speed in rpm. | | | | |
| Number of Motor Poles | Sets the number of motor poles. | | | | |
| Motor Selection | Chooses connected motor as 1st or 2nd motor. | | | | |

Be sure to uncouple the motor before beginning auto-tuning. After scrolling through tuning parameters using key, depress Run key to begin auto-tuning. During tuning, "Tune Proceeding" flashes on the digital operator display. After complete, "Tune Successful" is displayed.

Note: If the Stop key is depressed during tuning, auto-tuning is interrupted and the motor coasts to stop. The data changed during tuning returns to its original values.

After tuning is complete, depress the Menu key to exit the auto-tuning mode.

CHAPTER 4 DIAGNOSTICS

WARNING

Precautions

- 1) Never touch high voltage terminals in the inverter.
- 2) Replace all protective covers before powering up the inverter. When removing the cover, be sure to shut OFF the power supply to the inverter.
- 3) Perform maintenance or inspection only after verifying that the charge LED has gone OFF, after the main circuit power supply is turned OFF.
- 4) Only authorized personnel should be permitted to perform maintenance, inspections or parts replacement.

Failure to observe these precautions highlighted in this manual will expose the user to high voltages, resulting in equipment damage, serious injury or death.

CAUTION

Precautions

- ▶ The control PCB board employs CMOS ICs. Do not touch the CMOS elements.
- ▶ Do not connect or disconnect wiring or connectors while power is applied to the circuit.

Failure to observe these precautions may result in equipment damage.

4.1 MAINTENANCE & INSPECTION

This section describes basic maintenance and inspection procedures for the FST-800 Drive.

Periodic Inspection

The FST-800 Drive will function longer if it is kept clean, cool and dry, and if all precautions highlighted in this manual are observed. Periodically inspect the inverter as described in the table below to prevent accidents and to ensure high performance with high reliability.

To prevent electrical shock, disconnect all power before servicing the inverter. Then wait at least five minutes after the power supply is disconnected and all LEDs are extinguished.

| Component | Check | Corrective Action |
|---|--|---|
| External Terminals, Connectors, Mounting Screws, etc. | Loose screws or connectors | Securely tighten. |
| Heatsink | Build-up of dust and dirt | Blow with dry, compressed air [39.2×10^4 to 58.8×10^4 Pa (4 to $6\text{kg}\cdot\text{cm}^2$) pressure]. |
| Printed Circuit Board (PCB) | Accumulation of conductive dust or oil | Blow with dry, compressed air [39.2×10^4 to 58.8×10^4 Pa (4 to $6\text{kg}\cdot\text{cm}^2$) pressure]. If dust and oil cannot be removed, replace the board. |
| Cooling Fan | For abnormal noise and vibration | Replace the cooling fan. |
| Power Components | Accumulation of dust and dirt | Blow with dry, compressed air [39.2×10^4 to 58.8×10^4 Pa (4 to $6\text{kg}\cdot\text{cm}^2$) pressure]. |
| Smoothing Capacitor | Discoloration or odor | Replace the capacitor or the inverter. |

Parts Replacement Schedule

Replace the following parts periodically, for long, safe, trouble-free operation of the FST-800 Drive:

| Parts | Approximate Interval | Remarks |
|--|----------------------|--|
| Cooling Fan | 2 to 3 years | Replace with new one. |
| Smoothing Capacitor | 5 years | Replace with new one (after inspection). |
| Breakers or Relays | -- | Decide after inspection. |
| Fuses | 10 years | Replace with new one. |
| Aluminum Electrolytic Capacitor on PCB Board | 5 years | Replace with new one (after inspection). |

Optimum operating conditions:

Ambient temperature: 86°F yearly average
 Load factor: 80% or below
 Operation rate: 12 hours or less per day

4.2 ALARM & FAULT DISPLAYS

This section describes the alarm and fault displays, explanations for fault conditions, and corrective actions to be taken if the FST-800 Drive malfunctions.

Inverter Alarms & Faults

When the FST-800 Drive detects a fault, the fault is displayed on the digital operator and activates a fault contact output, after which the motor coasts to a stop. Check the causes listed in the table below and take the corresponding corrective actions. To restart the inverter, remove any run command and turn ON the reset input signal or depress the RESET key on the digital operator, or cycle power to reset the stop status. If taking the corrective actions described does not solve the problem, contact your Yaskawa representative immediately.

Unlike faults, alarms do not activate fault contact outputs. After the cause of the alarm is corrected, the inverter returns to its former operation status automatically.

Fault Diagnosis and Corrective Actions

| Fault Display | Name | Description | Corrective Action | Class |
|----------------------------|---|--|---|-------|
| UV1 DC Bus Undervolt | Main circuit undervoltage (PUV) | Undervoltage in the DC main circuit during running. <u>Detection level</u> 230 V class: Approx. 190 V or less 460 V class: Approx. 380 V or less 575 V class: Approx. 546 V or less | Check the power supply wiring. · Correct the line voltage | A |
| UV2CTL PS Undervolt | Control circuit under- voltage (CUV) | Undervoltage in the control circuit during running. | | A |
| UV3MC Answerback | MC fault | The pre-charge contactor opened during running. | | A |
| UV Under Voltage | Momentary power loss | The main circuit DC voltage fell below the PUV level. The control power source fell below the CUV level. The pre-charge contactor opened. | -- | B |
| OC Overcurrent | Overcurrent (OC) | The inverter output current exceeded the OC level. | · Check the motor coil resis- tance. · Extend the accel/decel time. · Check the motor insulation. · Multi-meter check. | A |
| GF Ground Fault | Ground fault (GF) | Inverter output grounding current exceeded 50% of inverter rated current. | · Check that motor insulation has not deteriorated. · Check that connection between inverter and motor is not damaged. | A |

| Fault Display | Name | Description | Corrective Action | Class |
|----------------------|---|---|--|-------|
| OV Overvoltage | Overvoltage (OV) | The main circuit direct current voltage exceeded the OV level. <u>Detection level</u> 230 V class: Approx. 410 V 460 V class: Approx. 820 V 575 V class: Approx. 1040 V | Extend the deceleration time, add braking circuit. | A |
| SC Short Circuit | Load short-circuit (SC) | Inverter output (load) is short-circuited. | · Check the motor coil resistance. · Check the motor installation. | A |
| PUF DC Bus Fuse Open | Fuse blown (FU) | · The DC bus fuse is blown. · The output transistors were damaged. | Check for damaged transistor, load side short circuit, grounding, etc. | A |
| OH Heatsink Over tmp | Heatsink overheat (OH1) | The transistor heatsink temperature exceeded the allowable value. | Check the fan and ambient temperature. | A |
| OL1 Motor Overloaded | Motor overload (OL1) | Inverter output exceeded the motor overload level. | Reduce the load. | A |
| OL2 Inv Overloaded | Inverter overload (OL2) | Inverter output exceeded the inverter overload level. | Reduce the load, extend the acceleration time. | A |
| PF Input Pha Loss | Input open-phase | Inverter input power supply has open phase. Large unbalance in input voltage. | · Check the line voltage. · Re-tighten the input terminal screws. | A |
| LF Output Pha Loss | Output open-phase | Inverter output has open-phase. | · Check the output wiring. · Check the motor impedance. · Re-tighten the output terminal screws. | A |
| RR Dyn Brk Transistr | Braking transistor failure | The braking transistor has failed. | The inverter requires repair. | A |
| RH Dyn Brk Resistor | Braking resistor unit overheat | The braking resistor unit temperature has exceeded the allowable value. (Protects only inverter built-in type) | Reduce the regenerative load. | A |
| OS Over speed | Overspeed (OS) | The motor speed exceeded the over-speed level. | -- | A |
| PGO PG open | PG open circuit (PGO) | The PG line is broken. | · Check the PG line. · Check the condition of the motor lock or the load. | A |
| DEV Speed Deviation | Speed deviation (DEV) | The deviation of the speed reference and speed feedback exceeded the regulation level. | Check the load. | B |
| EF External Fault | Simultaneous forward/reverse run commands | Both FWD and REV run commands are simultaneously input for 500ms or longer. | Check sequence circuit. | B |
| BB Base Block | External baseblock | External baseblock command is input from control circuit terminal. | Check sequence circuit. | B |

| Fault Display | Name | Description | Corrective Action | Class |
|-------------------------|--|---|---|-------|
| EF3 External Fault 3 | External fault at terminal 3 | Fault occurred in the external control circuit. | Check the condition of the input terminal. If the LED lights when terminal is not connected, then the inverter requires repair. | A |
| EF4 External Fault 4 | External fault at terminal 4 | Fault occurred in the external control circuit. | Check the condition of the input terminal. If the LED lights when terminal is not connected, then the inverter requires repair. | B |
| EF5 External Fault 5 | External fault at terminal 5 | | | |
| EF6 External Fault 6 | External fault at terminal 6 | | | |
| EF7 External Fault 7 | External fault at terminal 7 | | | |
| EF8 External Fault 8 | External fault at terminal 8 | | | |
| OPE01 kVA Selection | kVA setting error (OPE01) | Inverter kVA setting error. | Check and set the parameter data (O2-04). | C |
| OPE02 Limit | Parameter setting range error (OPE02) | Parameter data is out of range. | Check the parameter data settings. | C |
| OPE03 Terminal | Multi-function input setting error (OPE03) | <ul style="list-style-type: none"> · Multi-function input settings in H1-01 o H1-06 are not in ascending order. · Or, set values other than "F" are overlapping. | Check the function selection. | C |
| OPE10 V/f | V/f data setting error (E1-04 to E1-10) | V/f data is set such that the following equation is <i>not</i> satisfied: $E1-04 \quad E1-06 > E1-07 \quad E1-09$ | Check the parameter data settings. | C |
| OPE11 FC/ On-Dly | Parameter setting error | <p>When one of the following setting errors occurs:</p> <ul style="list-style-type: none"> · Carrier frequency upper limit (C6-01) > 5kHz, and Carrier frequency lower limit (C6-02)5kHz Carrier frequency proportional gain (C6-03) > 6 and (C6-01) < (C6-02) | Check the parameter data settings. | C |
| ERR EEPROM R/W Err | EEPROM writing fault(ERR) | EEPROM internal data did not match when initializing the parameter. | Replace the control board. | B |
| CALL Serial Com Call | SI-B transmission error | Control data was not received correctly when power supply was turned ON. | Check transmission devices and transmission signals. | C |
| CE Memobus Com Err | Transmission error | Control data was not received correctly when power supply was turned ON. | Check transmission devices and transmission signals. | A |

| Fault Display | Name | Description | Corrective Action | Class |
|---------------------------|---|---|---|-------|
| CPF00COM-ERR(OP&INV) | Control circuit fault 1 (CPF00) Digital perator transmission fault | · Transmission between the inverter and digital operator cannot be established 5 seconds after supplying power. · MPU peripheral element check fault (on-line) | · Insert the operator connector again. · Check the wiring of control circuit. · Replace the control board. | A |
| CPF01COM-ERR(OP&INV) | Control circuit fault 2 (CPF01) Digital perator transmission fault | · Transmission between the inverter and digital operator is established once after supplying power, but later transmission fault continues for more than 2 seconds. · MPU peripheral element check fault | · Insert the digital operator connector again. · Check the digital control circuit wiring. · Replace the control board. | A |
| CPF02 BB Circuit Err | Baseblock circuit fault (CPF02) | | | A |
| CPF03 EEPROM Error | EEPROM fault (CPF03) | | | A |
| CPF04 Internal A/D Err | CPU internal A/D converter fault (CPF04) | Inverter PCB control board fault. | Replace the control board. | A |
| CPF05 External A/D Err | CPU external A/D converter fault (CPF05) | | | A |
| CPF06 Option Error | Option connection fault (CPF06) | The option card is not installed correctly. | Install the option card again. | A |
| CPF20 Option A/D Error | A/D converter fault in analog speed reference card (CPF20) | Option card (AI-14B) A/D converter fault | Replace the option card. | A |

Classes are described as follows:

A: Major fault. Motor coasts to stop, operation indicator illuminates, and fault contact output (terminals 18 & 19) is activated.

B: Fault. Operation continues, operation indicator illuminates, and multi-function fault signal is output (when multi-function output is selected). Fault contact output is *not* activated.

C: Alarm (warning). Operation cannot be performed, and operation indicator illuminates, but *no* fault signal is output.

Motor Faults

If a motor fault occurs, follow the checkpoints listed in the table below and take the corresponding corrective actions. If taking the corrective actions described does not solve the problem, contact your Yaskawa representative immediately.

Motor Faults and Corrective Actions

| Fault | Check Point | Corrective Action |
|--|--|---|
| | Power supply voltage applied to power supply terminals L1, L2, L3? Charge LED is ON? | <ul style="list-style-type: none"> · Turn ON power supply. · Turn OFF power supply, and then ON again. · Check power supply voltage. · Make sure terminal screws are tight. |
| | Use rectifier type voltmeter to test. Voltage output to output terminals T1, T2, T3 correct? | Turn OFF power supply, then turn ON again. |
| Motor does not rotate | Motor locks due to excessive load? | Reduce the load and release the lock. |
| | Fault displayed in operator display? | Check troubleshooting table on page 64. |
| | FWD or REV run command entered? | Check the wiring. |
| | Frequency setting voltage entered (when using terminals 13 or 14)? | <ul style="list-style-type: none"> · Check the wiring. · Check frequency setting voltage. |
| | Are reference and run source settings correct? | Check reference and run source selections (B1-01, B1-02). |
| Motor rotation reverses | Wiring of terminals T1, T2, T3 correct? | Match wiring to the phase order of the motor leads T1, T2, T3. |
| | FWD and REV wiring run signals entered? | Correct the wiring. |
| Motor rotates, but variable speed not available. | Wiring of frequency setting circuit correct? | Correct the wiring. |
| | Are reference and run source settings correct? | Check reference and run source selections (B1-01, B1-02). |
| | Load excessively large? | Reduce the load. |
| | Motor ratings (number of poles, voltage) | Check motor nameplate specifications. |
| Motor rpm too high or too low | Accel/dec [∧] el speed change ratio for gears, etc. correct? | Check speed changer (gears, etc.) |
| | Maximum frequency set value correct? | Check the maximum frequency set value. |
| | Use rectifier voltmeter. Voltage between motor terminals not excessively reduced? | Check V/f characteristics values. |
| | Load excessively large? | Reduce the load. |
| | Load variation excessively large? | <ul style="list-style-type: none"> · Reduce the load variation. · Increase inverter motor capacity. |
| Motor rpm not stable during operation | 3-phase or single-phase power supply used? For 3-phase power supply, open phase? | <ul style="list-style-type: none"> · For 3-phase power supply, check the wiring if power supply is open phase. · For single-phase power supply, connect AC reactor to the power supply. |

CHAPTER 5 COPY MODE GUIDE

5.1. COPY MODE Specification:

- (1) Use E²PROM as save IC component, which don't need back up power.
- (2) Only allow same capacity of Anyhertz FST-800 inverter to enter copy parameter function,
- (3) During the copy mode, the below functions can be in proceed.
 - READ: Read the parameter from frequency inverter and write into E²PROM.
 - COPY: Save the parameter from keypad to frequency inverter.
 - VRFY: Automatically compare the parameter between keypad and frequency inverter
- (3) Only memory one piece frequency inverter's parameters

5.2. COPY MODE Explanation

There are 4-function keys of COPY MODE, which are COPY/MODE,READ,COPY,VRFY.

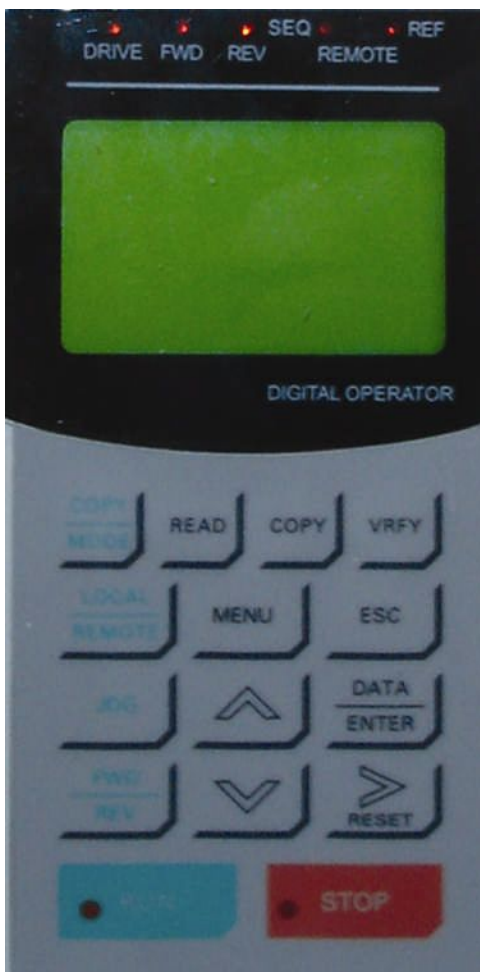

1. Drive Light On/Off indicator:
Drive mode: Light On PRGM
mode: Light off COPY mode:
Light flashing
2. COPY/MODE
Switch key between COPY mode and Drive
3. READ
Parameter Read Key
4. COPY
Parameter input key
5. VRFY
Parameter comparison key

5.3. OPERATION



Once power ON, the above keypad display under Drive Mode, Drive light on.

5.3.1 COPY MODE USER GUIDE:

| |
|--|
|  DANGER |
| <p>While switch COPY/MODE, control circuit terminal must be turn off. It is danger to switch COPY/MODE when motor is running.</p> |

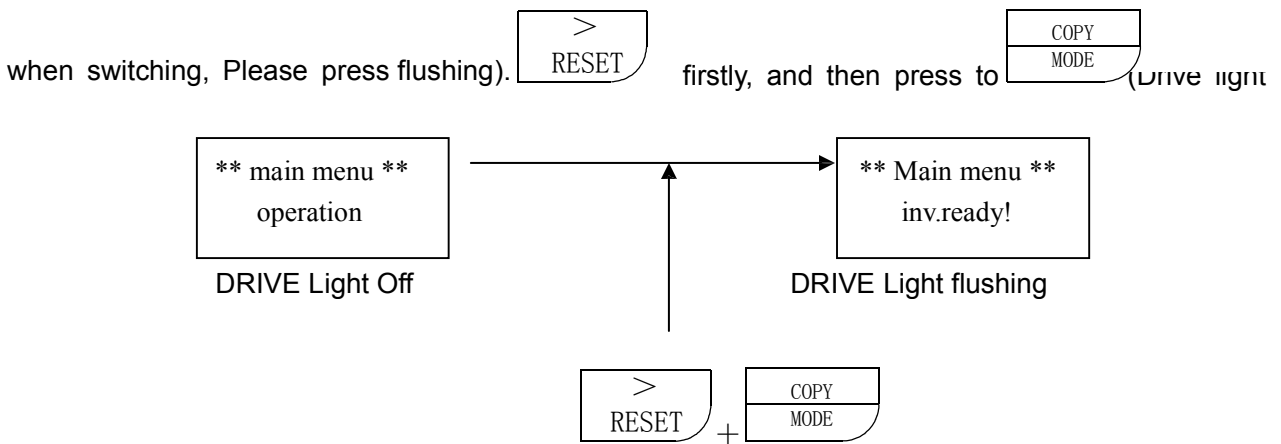
Only under main menu, COPY MODE can be switched from Drive Mode (Drive light on),

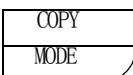

| DESCRIIION | KEY OPERATION | LED DISPLAY |
|---|---|---|
| <ul style="list-style-type: none"> ● DRIVE MODE |  | <div style="border: 1px solid black; padding: 5px; margin-bottom: 10px;"> <p>** Main menu ** Operation</p> </div> |
| <ul style="list-style-type: none"> ● COPY MODE switching |  +  | <div style="border: 1px solid black; padding: 5px;"> <p>** Copy mode ** inv.ready!</p> </div> |

From COPY MODE switch to DRIVE MODE, press  key only.

5.3.2 COPY MODE OPERATION GUIDE

(1) Read out (READ)

Read all the parameters from inverter, and then write into the keypad E^2 PROM function, which we called (READ). During read, we also delete all the parameter of E^2 PROM and replace them with latest parameter

Example: read parameter from the inverter

| DESCRIPIION | KEY OPERATION | LED DISPLAY |
|---|---|---|
| <ul style="list-style-type: none"> ● COPY MODE condition |  | <div style="border: 1px solid black; padding: 5px; width: fit-content; margin: 0 auto;"> ** Copy mode ** inv.ready! </div> |
| <ul style="list-style-type: none"> ● READ to execute | | <div style="border: 1px solid black; padding: 5px; width: fit-content; margin: 0 auto;"> ** Copy mode ** READ: ■■■■■■ </div> |
| <ul style="list-style-type: none"> ● READ to finish | | <div style="border: 1px solid black; padding: 5px; width: fit-content; margin: 0 auto;"> ** Copy mode ** read ok! </div> |

(2) Input (COPY)

Input the parameter from Keypad E^2 PROM to frequency inverter, which we called (COPY). This function is available for same capacity of the inverter only.

Example: Input inverter parameter

| DESCRIPIION | KEY OPERATION | LED DISPLAY |
|---|---|---|
| <ul style="list-style-type: none"> ● COPY MODE condition |  | <div style="border: 1px solid black; padding: 5px; width: fit-content; margin: 0 auto;"> ** Copy mode ** inv.ready! </div> |
| <ul style="list-style-type: none"> ● READ to execute. | | <div style="border: 1px solid black; padding: 5px; width: fit-content; margin: 0 auto;"> ** Copy mode ** COPY: ■■■■■■ </div> |
| <ul style="list-style-type: none"> ● READ to finish. | | <div style="border: 1px solid black; padding: 5px; width: fit-content; margin: 0 auto;"> ** Copy mode ** write ok! </div> |

(3) Comparing (VRFY)

The function to compare the parameters from the Keypad E²PROM with frequency inverter \mathfrak{S} parameters, which we call (VRFY), this function is available for same capacity of the inverter only.

Example:

| DESCRIIION | KEY OPERATION | LED DISPLAY |
|---|---|--|
| <ul style="list-style-type: none"> ● COPY MODE condition |  | <div style="border: 1px solid black; padding: 5px; width: fit-content; margin: 0 auto;"> ** Copy mode ** inv.ready! </div> |
| <ul style="list-style-type: none"> ● READ to execute. | | <div style="border: 1px solid black; padding: 5px; width: fit-content; margin: 0 auto;"> ** Copy mode ** VRFY: ■■■■■ </div> |
| <ul style="list-style-type: none"> ● READ to finish. | | <div style="border: 1px solid black; padding: 5px; width: fit-content; margin: 0 auto;"> ** Copy mode ** VRFY ok! </div> |

5.4. ERROR MESSAGE

| | | |
|-----|-----------------------------|---|
| (1) | COPE 00 Inv Status fault | Inverter abnormality |
| (2) | COPE 02 EEPROM fault | Inside E ² PROM of the keypad trouble |
| (3) | COPE 03 empty data | Inside E ² PROM of the keypad no date. |
| (4) | COPE 04 capacity fault | Inverter capacity fault |

CHAPTER 6 MENL PARAMETER

WARNING

Precautions

- a) Only turn ON the input power supply after replacing the front cover. Do not remove the cover while the inverter is powered up.
- b) When the retry function (parameter L5-02) is selected, do not approach the inverter or the load, since it may restart suddenly after being stopped.
- c) Since the Stop key can be disabled by a function setting, install a separate emergency stop switch.
- d) Do not touch the heatsink or braking resistor, due to very high temperatures.
- e) Since it is very easy to change operation speed from low to high speed, verify the safe working range of the motor and machine before operation.
- f) Install a separate holding brake, if necessary.
- g) Do not check signals during operation.
- h) All inverter parameters have been preset at the factory. Do not change the settings unless required.

Failure to observe these precautions may result in equipment damage, serious personal injury or death.

Notice

Printed Apr.2009. The information contained within this document is the proprietary property of Anyhertz . should not be copied, reproduced or transmitted to other producer without the expressed written authorization of Anyhertz.

No patent liability is assumed with respect to the use of the information contained herein. Moreover, because Anyhertz is constantly improving its high-quality products, the information contained in this manual is subject to change without notice. Every precaution has been taken in the preparation of this manual. Nevertheless, Anyhertz assumes no responsibility for errors or omissions. Neither is any liability assumed for damages resulting from the use of the information contained in this publication.

Introduction

Thank you for purchasing FST-800 Series high performance vector inverter. The FST-800 employs the latest hardware and software technology to provide unmatched performance, reliability and application flexibility.

The FST-800 flexible control mode architecture allows four choices of motor control technology for your application:

- Open Loop Vector is best for most applications, as it offers Adaptive Vector Control technology(AVC) for precise speed regulation, quick response and high starting torque.
- Closed Loop Flux Vector is the choice for applications requiring torque control, very precise speed regulation and full torque control at zero speed.
- V/f (Volts per Hertz) mode with Anyhertz's proprietary full range auto-torque boost provides ideal control for multi-motor applications.
- Closed Loop V/f allows encoder feedback for use with the Volts/hertz mode.

Use the following key to determine which control mode and access level are available for each parameter.

| No. | Parameter Name | LCD Display |
|-------|--------------------|-----------------|
| A1-00 | Language Selection | Select Language |

| V/ f | V/f w/PG | Open Loop Vector | Flux Vector |
|---------|----------|---------------------|----------------|
| Q | Q | Q | Q |

- Q: Quick-Start Level, selected parameters for maintenance-level programming
- B: Basic Level, selected parameters for basic programming in most applications
- A: Advanced Level, all parameters for advanced programming in special applications

The menu structure for all access levels are the same for the Operation, Initialize, Auto-tuning and Modified constants sections. The Programming section menu structure for each access level is as follows:

Quick-Start Access Level Structure

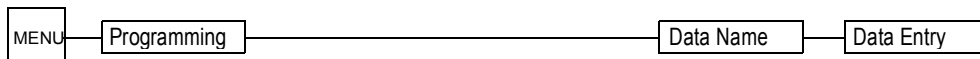

Basic Access Level Structure

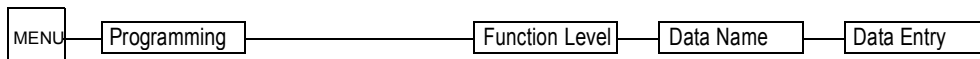

Advanced Access Level Structure

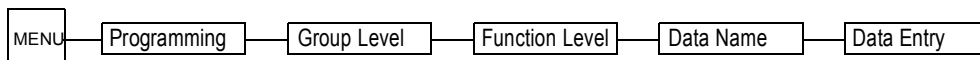

Software Version Explanation

Anyhertz recognizes the need to continuously improve product quality. This product may receive feature enhancements in the form of software or hardware changes. New programming parameters will be added to the latest programming manual. When a new parameter is added a software version note will be placed next to the parameter.

Software Version Example:

| | | | |
|---|---|---|---|
| Q | Q | Q | Q |
|---|---|---|---|

Select the language displayed on the digital operator according to the following table:

| Setting | Description |
|---------|------------------------------------|
| 0 | English (<i>factory default</i>) |
| 1 | Traditional Chinese |
| 2 | Simplified Chinese ◀ --- |
| 3 | German ▶ --- |
| 4 | French ▶ --- |
| 5 | Russian ▶ --- |
| 6 | Spanish ▶ --- |

This version note <1110> indicates that five additional languages have been added with software version 1110.

The part number of the main control printed circuit board on the drive reflects the software version. The software version normally increases to a higher number with newer versions. Please consult the factory for details.



The FST-800 ships preset to open loop vector control, quick-start access level. This publication describes all Quick-Start, Basic and Advanced parameters. For installation and simplified Quick-Start parameters.

FST-800 Series Parameter Tree

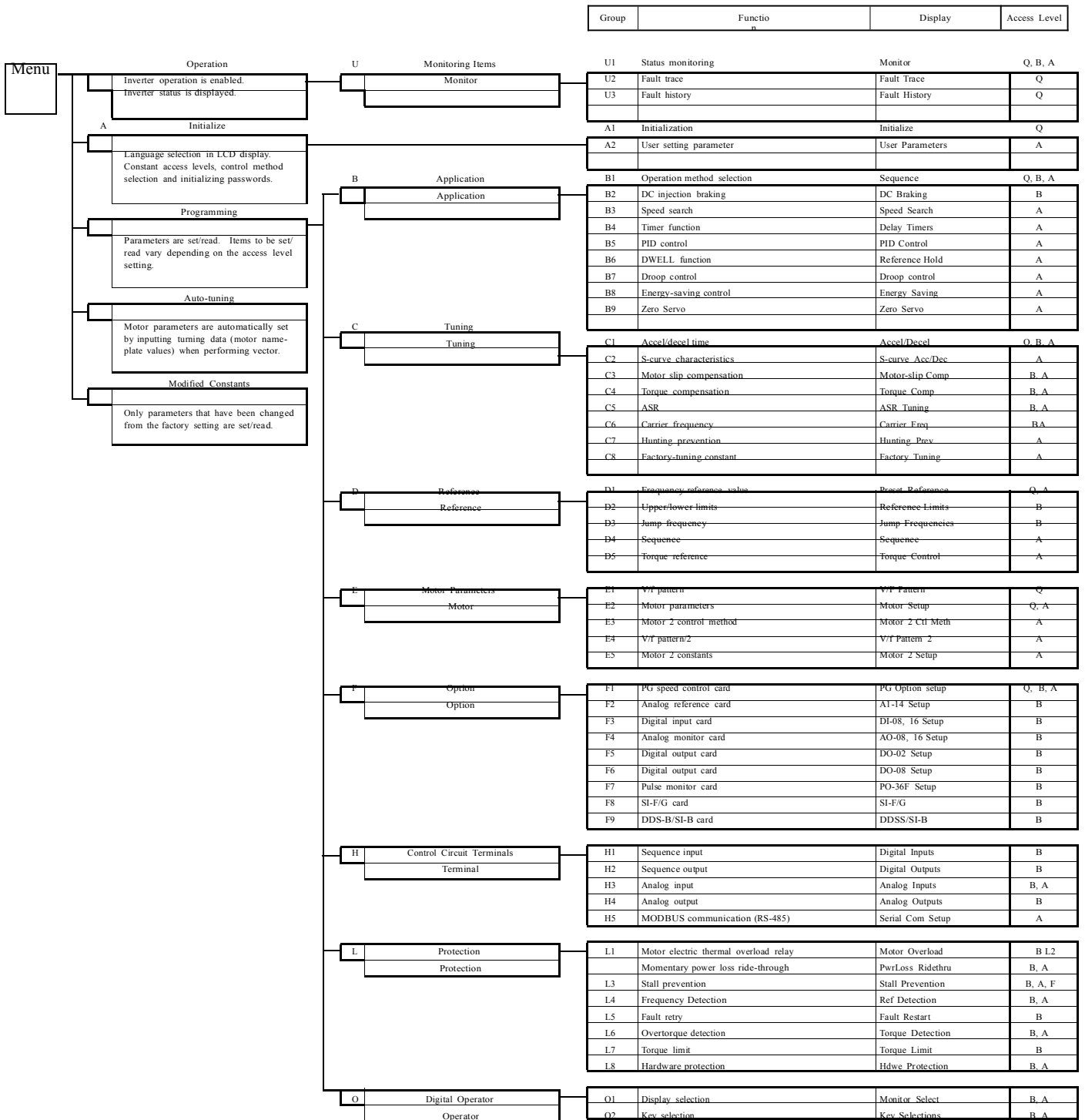

Main Menu: Initialize <ENTER>

A Initialization Parameters

A1 Initialization Set-up

A1-00 Language Selection

Select Language

| | | | |
|-----|----------|------------------|-------------|
| V/f | V/f w/PG | Open Loop Vector | Flux Vector |
| Q | Q | Q | Q |

Select the language displayed on the digital operator according to the following table:

| Setting | Description |
|---------|------------------------------------|
| 0 | English (<i>factory default</i>) |
| 1 | Traditional Chinese |
| 2 | Simplified Chinese |
| 3 | German |
| 4 | French |
| 5 | Russian |
| 6 | Spanish |

A1-01 Parameter Access Level

Access Level

| | | | |
|---|---|---|---|
| Q | Q | Q | Q |
|---|---|---|---|

This parameter allows the “masking” of parameters according to user level. See the following table:

| Setting | Description |
|---------|---|
| 0 | Operation Only |
| 1 | User Program - Accesses parameters selected by OEM (A2-01 to A2-32). |
| 2 | Quick Start Level (<i>factory default</i>) - For maintenance-level programming. |
| 3 | Basic Level - For basic programming in most applications. |
| 4 | Advanced Level - For advanced programming in special applications. |

A1-02 Control Method Selection

Control Method

| | | | |
|---|---|---|---|
| Q | Q | Q | Q |
|---|---|---|---|

Select the control method best suited for your application.

| Setting | Description |
|---------|---|
| 0 | V/f Control - For general-purpose and multiple motor applications. |
| 1 | V/f with PG Feedback - For general-purpose applications requiring closed loop speed control. |
| 2 | Open Loop Vector (<i>factory default</i>) - For applications requiring precise speed control, quick response and higher torque at low speeds (150% torque below 1Hz). |
| 3 | Flux Vector - For applications requiring very precise speed and torque control at a wide speed range including 0 speed. Uses encoder feedback. |

A1-03 Operator Status

Init Parameters

| | | | |
|---|---|---|---|
| Q | Q | Q | Q |
|---|---|---|---|

Use this parameter to reset the inverter to its factory default settings. Initialize the inverter after changing the control PCB, or after selecting language (A1-00), control method (A1-02), or inverter capacity(O2-04).

| Setting | Description |
|---------|--|
| 0 | No Initialization (<i>factory default</i>) |
| 1110 | User Initialization - resets the inverter to user-specified initial values. To set user-specified initial values, make all required changes to parameter settings, then set O2-03 to "1". The inverter will memorize all current settings as the user-specified initial values. Up to 50 changed parameters can be stored. |
| 2220 | 2-Wire Initialization - terminal 1 becomes FWD run command and terminal 2 becomes REV run command. All other parameters are reset to their original factory default settings. |
| 3330 | 3-Wire Initialization - terminal 1 becomes run command, terminal 2 becomes stop command and terminal 3 becomes FWD/ REV run selection. All other parameters are reset to their original factory default settings. |

A1-04 Password Entry

Enter Password

| | | | |
|---|---|---|---|
| Q | Q | Q | Q |
|---|---|---|---|

Parameter A1-04 is used to enter a password into the inverter, to be able to make adjustments to locked parameters.

- Password protection is provided for:
- A1-01 Access Level
- A1-02 Control Method
- A1-03 Initialization
- A2-01 to A2-32 User Parameters (If selected)

A2 User's Parameters

The user can select up to 32 parameters for quick-access programming. By setting the user access level (A1-01) to "User Program", only the parameters selected in function A2 can be accessed by the user.

Parameter A1-01 must be set to 4 (advanced access level) to input parameter numbers into A2-01 through A2-32, and then A1-01 must be set to 1 (User Level) for only the user selected parameters to be viewed

Main Menu: Programming <ENTER>

B Application Parameters

B1 Sequence

B1-01 Frequency Reference Selection

Reference Source

B1-02 Operation Method Selection

Run Source

| V/f | V/f w/PG | Open Loop Vector | Flux Vector |
|-----|----------|------------------|-------------|
| Q | Q | Q | Q |
| Q | Q | Q | Q |

Frequency reference and run command can be set independently as shown below:

| Setting | Description |
|---------|--|
| 0 | Command from digital operator |
| 1 | Command from control circuit terminal (<i>factory default</i>) |
| 2 | Command from serial communication |
| 3 | Command from option card |
| 4 | EWS (Reference from CP-717)* <1110> This setting will be used with the CP-717 to run and change the reference through DP-RAM. |

* Setting parameter B1-01 or B1-02 to 4 allows reference and/or run source from CP-717 when either CP-916 or CP-216 option cards are installed.

By depressing the LOCAL/REMOTE key on the digital operator, the operation mode can be selected as shown below:

Local: Operation according to frequency reference and run command from digital operator. Remote: Operation according to frequency reference and run command set by B1-01 and B1-02.

The digital operator is reset to remote operation when power is cycled.

B1-03 Stopping Method Selection

Stopping Method

| | | | |
|---|---|---|---|
| Q | Q | Q | Q |
|---|---|---|---|

This function selects the stopping method suitable for the particular application.

| Setting | Description |
|---------|---|
| 0 | Ramp to stop (<i>factory default</i>) |
| 1 | Coast to stop |
| 2 | DC injection to stop |
| 3 | Coast to stop with timer |

- Ramp to Stop ($B1-03 = "0"$)

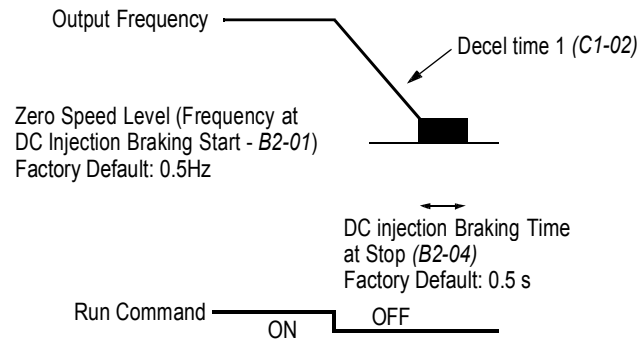

Figure 1 Stopping Method - Ramp to Stop

Upon removal of the FWD (REV) run command, the motor decelerates at a rate determined by the time set in deceleration time 1 ($C1-02$) and DC injection braking is applied after the minimum output frequency ($E1-09$) has been reached. If the deceleration time is set too short or the load inertia is large, an overvoltage fault (OV) may occur during deceleration. In this case, increase the deceleration time or install an optional braking transistor and/or braking resistor (braking transistors are provided as standard for units 230V 7.5kW and smaller, 460V 15kW and smaller).

Braking torque: without braking resistor, approx. 20% of motor rated torque
torque with braking option, approx. 150% of motor rated torque

- Coast to Stop ($B1-03 = "1"$)

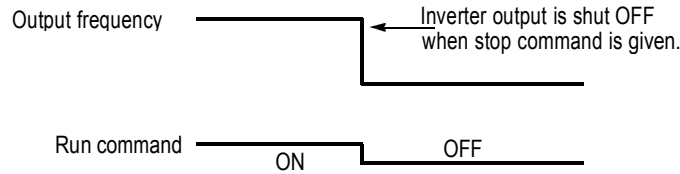

Figure 2 Stopping Method - Coast to Stop

Upon removal of the FWD (REV) run command, the motor starts to coast. After a stop command is given, a run command is accepted and operation will start after the minimum baseblock time ($L2-03$) elapses. If there is a possibility that a run command might be entered before the motor has come to a stop, the speed search function ($B3$) or Coast to Stop with Timer 1 ($B1-03 = "3"$) should be employed.

- DC Injection Braking to Stop ($B1-03 = "2"$)

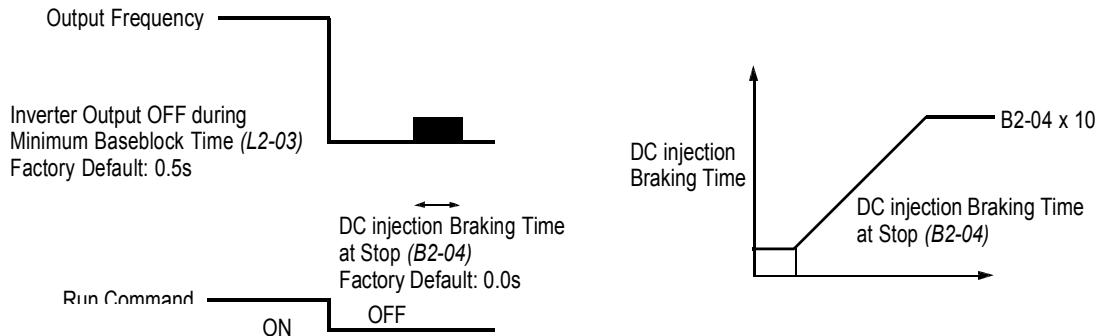

Figure 3 Stopping Method - DC Injection Braking to Stop

Upon removal of the FWD (REV) run command, the motor brakes to stop, according to the DC injection braking time at stop set in $B2-04$. If this value is set to "0" (*factory default*), DC injection braking is disabled, and the motor coasts to stop. When choosing this function, note that the actual stop time is the time set in $B2-04$ multiplied by 10 (see Figure 3 above). This stopping method is disabled during flux vector control. Braking duty cycle should allow excess motor heat to dissipate.

· Coast to Stop with Timer 1 (BI-03 = “3 ”)

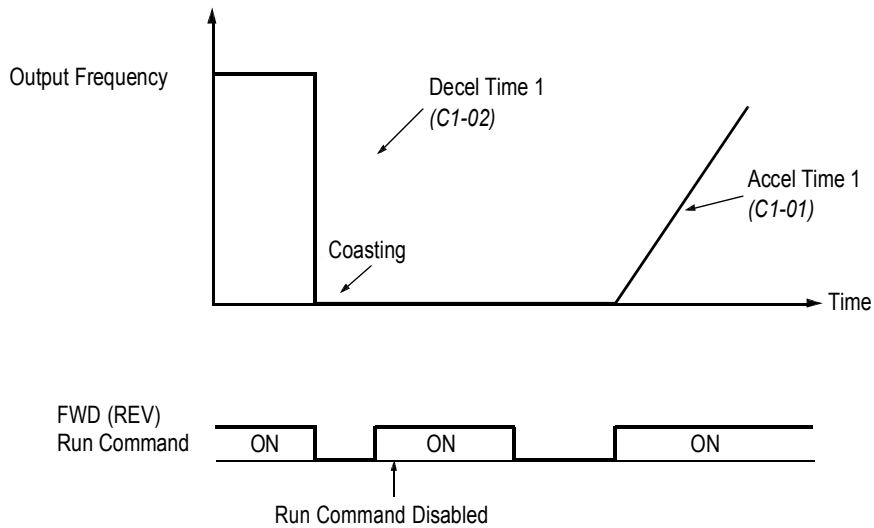

Figure 4 Stopping Method - Coast to Stop w/ Timer

After a stop command is given, a run command is not accepted while the coast to stop timer elapses (same as Decel 1). After the timer runs out, another run command must be given for the inverter to begin acceleration. This stopping method is disabled during flux vector control.

BI-04 Prohibition of Reverse Operation

Reverse Oper

| | | | |
|---|---|---|---|
| B | B | B | B |
|---|---|---|---|

A “reverse run disabled” setting does not allow a reverse run command from the control circuit terminal or the digital operator. This setting is used in applications where a reverse run command is undesirable.

| Setting | Description |
|---------|---------------------------------------|
| 0 | Reverse run enabled (factory default) |
| 1 | Reverse run disabled |

BI-05 Operation Selection at Zero Speed

Zero Speed Oper

| | | | |
|----|----|----|---|
| -- | -- | -- | A |
|----|----|----|---|

During flux vector control, select an operation mode to be employed when the frequency reference (analog input) drops below the minimum output frequency (E1-09). During V/f or open loop vector control, baseblock is applied when the output frequency drops below the minimum output frequency (E1-09).

| Setting | Description |
|---------|--|
| 0 | E1-09 disabled, run according to frequency reference (factory default) |
| 1 | Baseblock |
| 2 | Run at minimum output frequency (E1-09) |
| 3 | Zero-speed operation (internal speed reference is set to “0”) |

B1-06 *Input Scan Time*

Cntl Input Scans

| | | | |
|---|---|---|---|
| B | B | B | B |
|---|---|---|---|

This parameter selects the microprocessor scan time for reading sequence input data from the control circuit terminals.

| Setting | Description |
|---------|--|
| 0 | 2ms scan time for 2 scans |
| 1 | 5ms scan time for 2 scans (<i>factory default</i>) |

Set to “0” when a quicker response is needed from the control circuit terminals.

B1-07 *Operation Selection After Switch to Remote Mode LOC/REM RUN Sel*

| | | | |
|---|---|---|---|
| A | A | A | A |
|---|---|---|---|

Parameter b1-07 determines how the inverter will function when switching between local and remote operation. This function prevents the motor from running when switching between local/remote and the inverter is controlled from the digital operator.

| Setting | Description |
|---------|---|
| 0 | (Cycle Extrn RUN) - If the run command is closed when switching from local control to remote control, the inverter will not run. <i>The run command must be cycled for the inverter to run. (factory default)</i> |
| 1 | (Accept Extrn RUN) - If the run command is closed, when switching from local control to remote control, the inverter will run. |

B1-08 *Run Command Acceptance During Programming RUN CMD at PRG*

| | | | |
|---|---|---|---|
| A | A | A | A |
|---|---|---|---|

As a safety precaution the drive will not respond to a change in the run command when the digital operator is being used to set or adjust parameters. This parameter will allow the drive to accept or reject a change in the run command when the digital operator is being used to change or adjust parameters. <1110>

Table 1:

| Setting | Description |
|---------|---|
| 0 | Run command is disabled when drive is in the programming mode. (<i>factory default</i>) |
| 1 | Run command is enabled when the drive is in the program mode |

B2 *DC Braking*

B2-01 *DC Braking Frequency (Zero Speed Level)*

DCInj Start Freq

| | | | |
|---|---|---|---|
| B | B | B | B |
|---|---|---|---|

Setting Range: 0.0 to 10.0Hz
 Factory Default: 0.5Hz

Sets the frequency at which DC injection braking (or initial excitation for flux vector control) starts, in units of 0.1 Hz. When *B2-01* < *E1-09*, DC injection braking starts from the minimum frequency reference (*E1-09*).

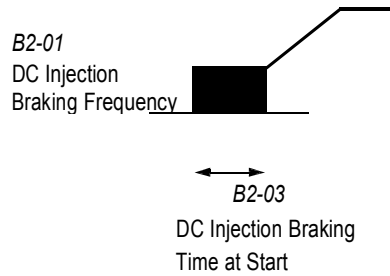

Figure 5 DC Injection Braking at Starting

B2-02 DC Braking Current

DCInj Current

| | | | |
|---|---|---|----|
| B | B | B | -- |
|---|---|---|----|

Setting Range: 0 to 100%
 Factory Default: 50%

DC injection braking current is set as a percentage of inverter rated current. In flux vector control mode, initial excitation is performed according to the motor no-load current set in E2-03. This parameter should not be set unnecessarily high or motor overexcitation may occur.

B2-03 DC Braking Time at Start
 Time@Start

DCInj

| | | | |
|---|---|---|---|
| B | B | B | B |
|---|---|---|---|

Setting Range: 0.00 to 10.00s
 Factory Default: 0.00s

DC injection braking at start can be used to stop a spinning motor (or when motor rotation direction is unknown) prior to running. DC injection braking time at start (or initial excitation for flux vector control) is set in units of 0.1 second. When B2-03 is set to "0", DC injection braking is disabled and acceleration starts from the minimum output frequency.

B2-04 DC Braking Time at Stop

DCInj Time@Stop

| | | | |
|---|---|---|---|
| B | B | B | B |
|---|---|---|---|

Setting Range: 0.00 to 10.00s
 Factory Default: 0.00s

DC injection braking time at stop (or initial excitation for flux vector control) is set in units of 0.1 second. When B2-04 is set to "0", DC injection braking is disabled, and the inverter output shuts OFF.

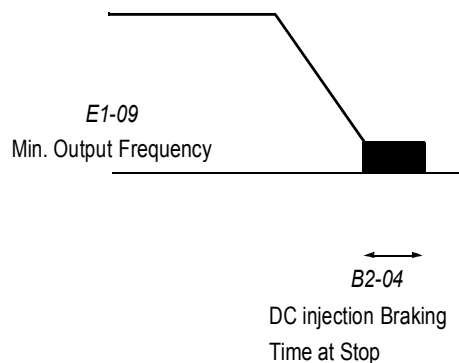

Figure 6 DC Injection Braking Time at Stop

When coast to stop is selected as the stopping method (B1-03), DC injection braking at stop is disabled.

B2-08 *Magnetic Flux Compensation Level* <1110>

FieldComp

| | | | |
|---|----|---|---|
| - | -- | A | A |
|---|----|---|---|

Setting Range: 0 to 500%
 Factory Default: 0%

This parameter allows the magnetizing motor flux to be boosted when starting the motor. This parameter will facilitate a quick ramp-up of the torque reference and magnetizing current reference to reduce motor slip during start. A setting of 100% equals motor no-load current E1-09. This flux level will be applied below *Minimum Output Frequency* (E1-09) until the *DC Injection Time at Start* (B2-03) expires. This parameter is useful when starting motors that are relatively larger than the inverter, due to the requirement for increased magnetizing current. This parameter may also compensate for reduced starting torque due to motor circuit inefficiencies.

B3 Speed Search

When starting into a coasting motor, use the speed search command or DC injection braking at start, to prevent a drive trip and motor burnout.

This function allows the restart into a coasting motor without the necessity to stop. It is useful during inverter bypass operation, when switching between the motor receiving power directly from the line and from the inverter. Two interlocking contactors must be employed for commercial power switchover to prevent line power from being applied to the inverter output terminals.

Set the multi-function contact input selection (H1-01 to H1-06) to “61” (start search command from maximum output frequency), “62” (start search command from the set frequency), or “64” (start search command from the SFS frequency when baseblock is applied).

B3-01 *Speed Search after Run Command*

SpdSrch at Start

| | | | |
|---|----|---|----|
| A | -- | A | -- |
|---|----|---|----|

| Setting | Description |
|---------|---|
| 0 | Speed search disabled, the motor accelerates to the set frequency from the min. frequency reference after run command is given (<i>factory default</i>). |
| 1 | Speed search enabled after run command is given, according to multi-function contact input selection. When using an encoder, the motor accelerates/decelerates to the set frequency from the motor speed. |

Note: This parameter is disabled except when (A1-02=1) (V/F w/PG Fdbk) or 3 (Flux Vector)

B3-02 *Speed Search Detection Current Level*

SpdSrch Current

| | | | |
|---|----|---|----|
| A | -- | A | -- |
|---|----|---|----|

Setting Range: 0 to 200%
 Factory Default: 150%

After power loss and recovery, speed search begins to ramp the frequency down from a specified point in order to locate the frequency of the spinning motor. During initial speed search the inverter’s output current exceeds the speed search detection current level. This level is set as a percentage of inverter rated current. When the inverter’s output current is less than the speed search detection level, the frequency is interpreted as the speed agree level, and the inverter accelerates/decelerates to the specified frequency.

Note: Factory setting defaults to 150 when A1-02=0 (V/F Control). When A1-02=2 (Open Loop Vector), the default is 100.

B3-03 Speed Search Deceleration Time

SpdSrch Dec Time

| | | | |
|---|----|---|----|
| A | -- | A | -- |
|---|----|---|----|

Setting Range: 0.1 to 10.0s
 Factory Default: 2.0s

Sets deceleration time during speed search in units of 0.1 second. When speed search deceleration time is set to 0.0 second, speed search is disabled. The speed search deceleration time should be set to be somewhat faster than the decel rate of coasting motor. Build an input sequence so that the speed search command is input at the same time or prior to the FWD (REV) run command. If the run command is input before the search command, the search command is not effective. Below is a timing diagram of the search command input:

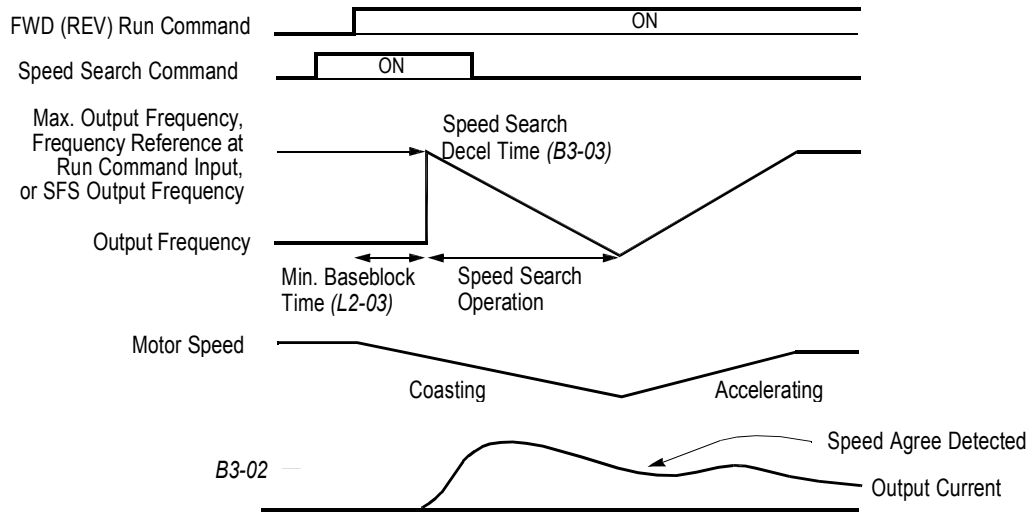

Figure 7 Search Command Input Timing Diagram

B4 Delay Timers

The inverter input and output contacts can be used in place of an external timer. When multi-function contact input (H1-__ = "18") is closed, a multi-function contact output (H2-__ = "12") can be set to close after the On-delay time (B4-01) has expired. When multi-function contact input (H1-__ = "18") is opened, a multi-function contact output (H2-__ = "12") can be set to open after the Off-delay time (B4-01) has expired. This function operates independently of any action the inverter is performing.

| | | |
|--------------|-----------------------|---------------|
| B4-01 | <i>On-delay Timer</i> | |
| | Setting Range: | 0.0 to 100.0s |
| | Factory Default: | 0.0s |

Delay-ON Timer

| | | | |
|---|---|---|---|
| A | A | A | A |
|---|---|---|---|

Sets the ON-delay time in units of 0.1 second. The multi-function input must be "closed" for longer than the ON-delay timer for the multi-function output to close.

B4-02 Off-delay Timer
Timer

Delay-OFF

| | | | |
|---|---|---|---|
| A | A | A | A |
|---|---|---|---|

Setting Range: 0.0 to 100.0s
Factory Default: 0.0s

Sets the OFF-delay time in units of 0.1 second. The multi-function input must be “open” for longer than the OFF-delay timer for the multi-function output to open.

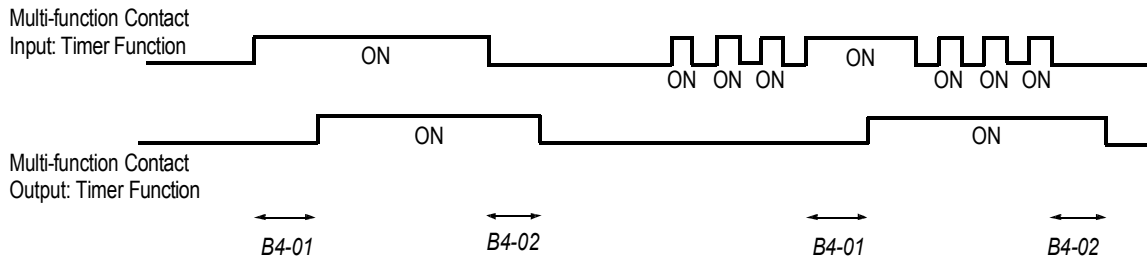

Figure 8 Timing Diagram of Timer Function

B5 PID Control

The Proportional, Integral and Derivative (PID) control function provides closed-loop control and regulation of a system variable such as temperature or pressure. A control signal based on the difference (or proportion) between a feedback signal and a desired setpoint is produced. Integration and derivative calculations are then performed on this signal, based upon the PID parameter settings (B5-01 to B5-08), to minimize deviation, for more precise control.

Proportional - P

PID refers to the type of action used to control modulating equipment such as valves or dampers. With **proportional** control, a control signal based on the difference between an actual condition and a desired condition is produced. The difference, such as that between an actual temperature and setpoint is the “error”. The inverter adjusts its output signal related directly to the error magnitude.

Integral - I

The **integral** action is designed to minimize offset. An integrating term is used to observe how long the error condition has existed, summing the error over time. Once the system has stabilized, the offset would be minimized.

Derivative - D

Overshoot refers to a control loop tendency to overcompensate for an error condition, causing a new error in the opposite direction. **Derivative** action provides an anticipatory function that exerts a “braking” action on the control loop. When combined, the proportional integral, and **derivative** actions provide quick response to error, close adherence to the setpoint, and control stability.

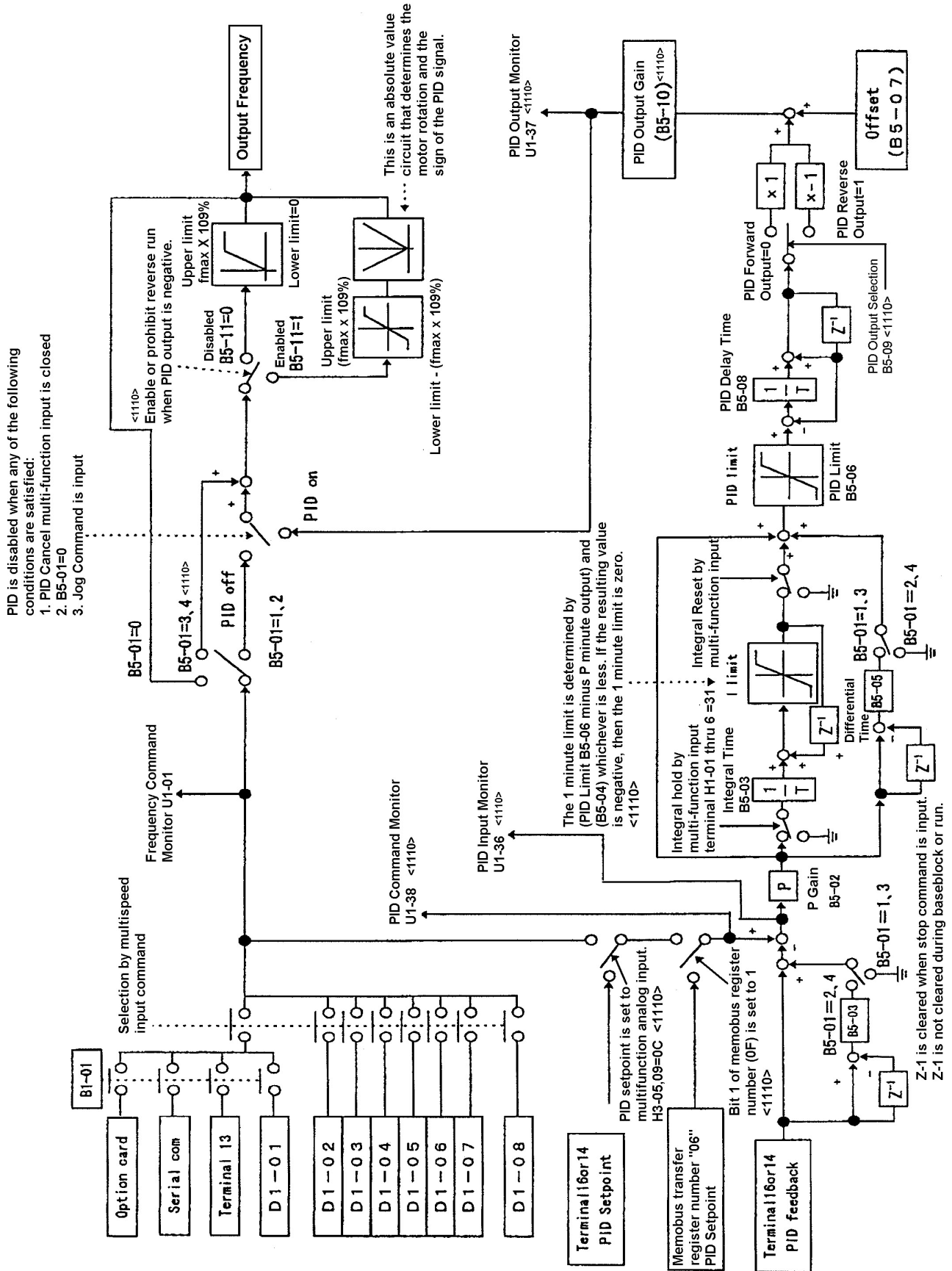

Figure 9 PID Block Diagram

B5-01 PID Control Mode Selection

PID Mode

| | | | |
|---|---|---|---|
| A | A | A | A |
|---|---|---|---|

To enable PID control, set PID control mode selection to “1” or “4”, according to the description below. Also be sure to set terminal 16 function selection (*H3-05*) to PID feedback (setting: “B”).

| Setting | Description |
|----------|---|
| 0 | PID disabled (<i>factory default</i>) |
| 1 | PID enabled (deviation signal is put through derivative control) |
| 2 | PID with feed forward (feedback signal is put through derivative control) |
| 3 <1110> | Reference= Frequency reference + PID output, D is Fdbk |
| 4 <1110> | Reference= Frequency reference + PID output, D is feed-forward |

Notes:

1. PID with feed forward applies control much quicker than normal PID, without waiting for the deviation signal to build up.
2. A PID inverse feedback signal can be selected by inverting the settings for terminal 16 gain and bias.

Then select the PID control intended value setpoint or detected feedback value setpoint as follows:

Intended Value Setting

The control circuit terminal 16 voltage signal (0 to 10V, -10 to 10V) or multi-step speed parameters *H1-03* to *H1-06* can be used to set the PID intended value.

Control circuit terminal 16 voltage signal:

Set reference selection (*B1-01*) to “1”.

Multi-step speed parameters (*H1-03* to *H1-06*):

Set reference selection (*B1-01*) to “0”.

(combination of multi-step speed references and jog frequency reference)

Detected Value Setting (Feedback)

The control circuit terminal 14 current signal (4 to 20mA) or voltage signals (0 to 10V, -10 to 10V) can be used to set the PID detected value.

Control circuit terminal 14 current signal:

Set terminal 14 signal selection (*H3-08*) to “2”.

Control circuit terminal 14 voltage signal:

Set terminal 14 signal selection (*H3-08*) to “0” or “1”

Notes:

1. I value is reset to “0” when operation stops.
2. The upper limit of the I value can be set by parameter *B5-04*. Increase the value of parameter *B5-04* to upgrade control capability by integration. If the control system vibrates and it cannot be stopped by adjusting the integral time, output delay time, etc., decrease the set value of parameter *B5-04*.
3. PID control can be canceled by a multi-function contact input signal. By setting any of parameters *H1-01* to *H1-06* to “19” and by closing the contact during running, PID control is disabled and the intended value signal itself is used as a frequency reference signal.

*B5-02 PID Control Proportional Gain**PID Gain*

| | | | |
|---|---|---|---|
| A | A | A | A |
|---|---|---|---|

Setting Range: 0.00 to 25.00

Factory Default: 1.00

The proportional gain is the value by which the deviation signal is multiplied to generate a new frequency reference.

*B5-03 PID Control Integral Time**PID I Time*

| | | | |
|---|---|---|---|
| A | A | A | A |
|---|---|---|---|

Setting Range: 0.00 to 360.0 seconds

Factory Default: 1.00 seconds

The integral calculation sums the deviation over time, which eliminates the offset, thus achieving the intended value. The integral time determines how quickly the integral gain increase is added to the control loop.

*B5-04 PID Control Integral Limit**PID I Limit*

| | | | |
|---|---|---|---|
| A | A | A | A |
|---|---|---|---|

Setting Range: 0.0 to 100.0%

Factory Default: 100.0%

The integral limit value eliminates oscillations and improves stability. This value is set as a percentage of maximum output frequency (*E1-04*).

*B5-05 PID Control Derivative Time**PID D Time*

| | | | |
|---|---|---|---|
| A | A | A | A |
|---|---|---|---|

Setting Range: 0.00 to 10.00 seconds

Factory Default: 0.00 seconds

The derivative calculation attempts to control the remaining overshoot left over after the proportion and integral calculations. If the system is approaching the intended value very rapidly, the derivative control produces a strong braking action to prevent overshoot. If the system is already stable with very little deviation change, derivative control has very little effect. The derivative time is used to dampen oscillations and reduce overshoot, thus improving stability. Setting the derivative time to a larger number produces more braking action in the control system.

*B5-06 PID Control limit**PID Limit*

| | | | |
|---|---|---|---|
| A | A | A | A |
|---|---|---|---|

Setting Range: 0.0 to 100.0%

Factory.Default 100.0%

The PID limit value further eliminates oscillations and improves stability. This value is set as a percentage of maximum output frequency (*E1-04*).

*B5-07 PID Control Offset**PID Offset*

| | | | |
|---|---|---|---|
| A | A | A | A |
|---|---|---|---|

Setting Range: -100.0% to

+100.0% Factory Default: 0.0%

The PID offset adds a bias to the calculated PID value, in order to reduce any offset.

B5-08 PID Control Output Primary Delay Time

PID Delay Time

| | | | |
|---|---|---|---|
| A | A | A | A |
|---|---|---|---|

Setting Range: 0.00 to 100.0 seconds
 Factory Default: 0.00 seconds

The output delay time is used to delay changes in the calculated PID value, which can prevent oscillations and improve stability.

Parameters *B5-04* and *B5-06* to *B5-08* are preset at the factory to optimum values for most applications, hence, do not need to be changed. When tuning a system, first adjust the proportional gain until oscillations are reduced. Then adjust the integral time so that minimal deviation is achieved as quickly as possible, without oscillations. Finally, adjust the derivative time to reduce any overshoot at start-up.

B5-09 PID Output Selection <1110>

Output Level Sel

| | | | |
|---|---|---|---|
| A | A | A | A |
|---|---|---|---|

The PID output term for the inverter control can be either negative or positive output.

| Setting | Description |
|---------|---|
| 0 | PID Normal or Forward Output (<i>factory default</i>) Increase in the manipulated variable when the process variable is larger than the setpoint and decrease the manipulated variable when the process variable is smaller. |
| 1 | PID Reverse or Inverse Output Increase the manipulated variable when the process variable is smaller than the setpoint and decrease the manipulated variable when the process variable is larger than the setpoint. |

B5-10 PID Output Gain <1110>

Output Gain

| | | | |
|---|---|---|---|
| A | A | A | A |
|---|---|---|---|

Setting Range: 0.0 to 25.0
 Factory Default: 1.0

This parameter sets the gain of the PID output. The PID output can be monitored by parameter *U1-37 PID Output Monitor*. Refer to PID Block Diagram Figure 9.

B5-11 PID Output Reverse <1110>

Output Rev Sel

| | | | |
|---|---|---|---|
| A | A | A | A |
|---|---|---|---|

This parameter is used when the motor is required to change direction during PID operation in response to a negative PID output signal. The PID output can be monitored using parameter *U1-37 PID Output Monitor*.

| Setting | Description |
|---------|---|
| 0 | Zero limit (<i>factory default</i>) When PID output is negative, motor direction is not changed. The PID output is limited to 0. |
| 1 | Reverse When PID output is negative the motor will reverse direction. |

Note: When *Reverse Prohibit B1-04* is selected, reverse will not operate.

B5-12 Loss of Feedback Action <1110>

Fb Los Det Sel

| | | | |
|---|---|---|---|
| A | A | A | A |
|---|---|---|---|

This parameter is used to select what action the inverter will take on a loss of PID feedback. A loss of PID feedback occurs when the feedback signal falls below the *B5-13 Feedback Loss Detection Level* for the time set by *B5-14 Feedback Loss Detection Time*.

| Setting | Description |
|---------|---|
| 0 | Disabled (<i>factory default</i>) PID feedback missing detection is disabled. |
| 1 | Alarm PID feedback missing detection is enabled. Operation continues after loss of feedback. The text "Fbl" will be displayed on the digital operator. |
| 2 | Fault PID feedback missing detection is enabled. The inverter output to the motor is shut off (the motor is stopped) and "Fbl" is displayed on the digital operator. |

B5-13 PID Feedback Loss Detection Level <1110>

Fb los Det Lvl

| | | | |
|---|---|---|---|
| A | A | A | A |
|---|---|---|---|

Setting Range: 0 to 100%
Factory Default: 1%

This parameter sets the level at which a loss of PID feedback is detected. The PID feedback must be at or below this level for the time defined by *B5-14* before a loss of feedback can be detected. A setting of 100% represents 100% of the feedback signal.

B5-14 PID Output Gain <1110>

Output Gain

| | | | |
|---|---|---|---|
| A | A | A | A |
|---|---|---|---|

Setting Range: 0.0 to 25.0
Factory Default: 1.0

This parameter sets the gain of the PID output. The PID output can be monitored by parameter *U1-37 PID Output Monitor*. Refer to PID Block Diagram Figure 9.

B6 Reference Hold

The reference hold or dwell function is used to temporarily hold the output frequency at a set reference, for a set time, and then start it again. This function can be used when driving a permanent magnet motor, or a motor with a heavy starting load. This pause in acceleration allows the magnets in a permanent magnet motor to synchronize with the stator field of the motor, thus reducing traditionally high starting current.

B6-01 Dwell Frequency Reference at Start @Start

Dwell Ref

| | | | |
|---|---|---|---|
| A | A | A | A |
|---|---|---|---|

Setting Range: 0.0 to 400.0Hz
Factory Default: 0.0Hz

Sets the dwell frequency reference during acceleration in units of 0.1Hz.

B6-02 Dwell Time at Start

Dwell Time@Start

| | | | |
|---|---|---|---|
| A | A | A | A |
|---|---|---|---|

Setting Range: 0.0 to 10.0s
Factory Default: 0.0s

Sets the amount of time that the frequency reference “dwells” during acceleration in units of 0.1s.

B6-03 Dwell Frequency Reference at Stop

Dwell Ref @Stop

| | | | |
|---|---|---|---|
| A | A | A | A |
|---|---|---|---|

Setting Range: 0.0 to 400.0Hz
Factory Default: 0.0Hz

Sets the dwell frequency reference during deceleration in units of 0.1Hz.

B6-04 Dwell Time at Stop

Dwell Time @Stop

| | | | |
|---|---|---|---|
| A | A | A | A |
|---|---|---|---|

Setting Range: 0.0 to 10.0s
Factory Default: 0.0s

Sets the amount of time that the frequency reference “dwells” during deceleration in units of 0.1s.

B7 Droop Control

The Drooping function reduces the motor speed based on the load torque of the motor.

B7-01 Droop Control Gain

Droop Quantity

| | | | |
|----|----|----|---|
| -- | -- | -- | A |
|----|----|----|---|

Setting Range: 0.0 to 100.0
Factory Default: 0.0

Parameter b7-01 sets the amount of motor speed reduction when the motor is producing 100% of rated torque. The actual amount of motor speed reduction is based on the ratio of the amount of motor torque and the maximum output frequency (E1-04).

B7-02 Droop Control Delay Time

Droop Delay

| | | | |
|---|----|----|---|
| - | -- | -- | A |
|---|----|----|---|

Setting Range: 0.03 to 2.00
Factory Default: 0.05

Parameter b7-02 sets the response time for the drooping function. Decreasing the droop delay time, will cause the response to become quicker; however, instability may occur.

B8 Energy Saving

This feature can save energy during operation under lightly loaded conditions, by decreasing output voltage, energy-saving operation is made available. Energy saving control is enabled by a **multi-function contact input**, when control mode selection (A1-02) is set to "0" (V/f Control) or "1" (V/f w/PG Fdbk). Parameters B8-03, B8-04 and B8-05 are for energy savings in the vector modes. B8-01 and B8-02 are only functional in the V/f modes via a multi-function input command. Parameters B8-03, B8-04 and B8-05 are for automatic energy savings in the vector modes.

B8-01 Energy Saving Gain

Energy Save

| | | | |
|---|---|----|----|
| A | A | -- | -- |
|---|---|----|----|

Setting Range: 0 to 100%
Factory Default: 80%

The output voltage during energy-saving operation is the product of the normal V/f settings (E1-03 to E1-10) and the energy saving gain. The output voltage decreases and recovers in the voltage recovery time (L2-04). As the energy saving gain increases, the output voltage increases also. **This feature is only enabled by a multi-function contact input.**

B8-02 Energy Saving Starting Frequency

Energy Save Freq

| | | | |
|---|---|----|----|
| A | A | -- | -- |
|---|---|----|----|

Setting Range: 0.0 to 400.0Hz
Factory Default: 0.0Hz

After the multi-function contact input for energy-saving operation closes (H1-___, setting: "63"), the output voltage is decreased when the output frequency reaches the energy-saving starting frequency. This feature is only enable by multi-function contact input.

B8-03 Automatic Energy Saving <1110>

Energy Save Sel

| | | | |
|---|---|---|---|
| - | - | A | A |
|---|---|---|---|

This parameter is used to select if Automatic Energy Saving Mode is to be on or off. A multi-function contact input **is not** required to activate Automatic Energy Saving Mode. This mode of operation automatically searches for the optimum motor voltage required to save energy. This function is separate and not to be confused with parameters B8-01 and B8-02. The energy saving mode that utilizes B8-01 and B8-02 requires a multi-function input to be activated for operation. This Automatic Energy Saving Mode selection **does not** require a multi-function input to activate operation.

| Setting | Description |
|---------|--|
| 0 | Disabled (<i>factory default</i>) Energy saving mode will not be activated under light loads. |
| 1 | Enabled The energy saving mode will be activated under light loads. |

B8-04 Energy Saving Control Gain

Energy Save Gain

| | | | |
|---|----|---|---|
| - | -- | A | A |
|---|----|---|---|

Setting Range: 0 to 10.0

Factory Default: 0.7

The output voltage during energy-saving operation is the product of the normal V/f settings (E1-03 to E1-10) and the energy saving gain. The output voltage decreases and recovers according to the Energy-Saving Control Time Constant B8-05. As the energy saving gain increases, the output voltage increases also.

Note: When the control mode A1-02=3, the default factory setting becomes 1.0

B8-05 Energy Control Time-Constant

Energy Save F. T

| | | | |
|---|----|---|---|
| - | -- | A | A |
|---|----|---|---|

Setting Range: 0.00 to 10.00

Factory Default: 0.50

Parameter B8-05 sets the response time for the Automatic Energy Saving function.

Decreasing the Energy Control Time-Constant, will cause the response to become quicker; however, instability may occur if this is decreased too much.

Note: When control mode A1-02=3, the default factory setting becomes 0.01.

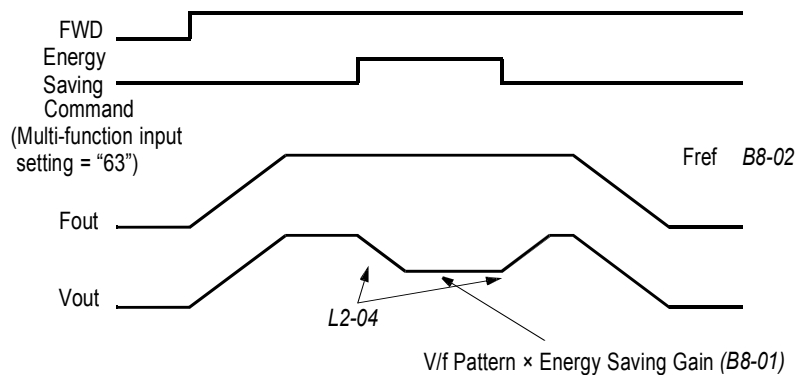

Figure 10 Timing Diagram of Energy Saving Function

B9 Zero Servo

The zero servo function is enabled when the multi-function contact input is set to zero servo command ($H1-__ = "72"$). The motor position is then memorized when motor speed feedback is less than the zero speed level ($B2-01$).

B9-01 Zero Servo Gain

Zero Servo Gain

| | | | |
|----|----|----|---|
| -- | -- | -- | A |
|----|----|----|---|

Setting Range: 0 to 100
 Factory Default: 5

Sets the zero-servo position loop gain. When adjusting the gain, the higher the setting, the quicker the response. However, if the gain is set too high, it can cause overshoot and a possible runaway condition.

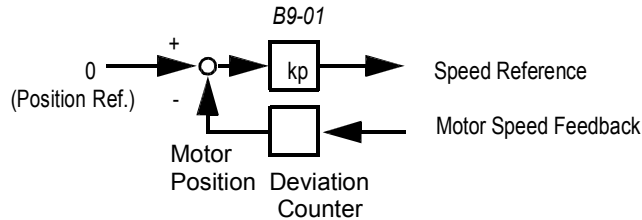

Figure 11 Zero Servo Position Loop

B9-02 Zero Servo Bandwidth Count

Zero Servo

| | | | |
|----|----|----|---|
| -- | -- | -- | A |
|----|----|----|---|

Setting Range: 0 to 16383 pulses
 Factory Default: 10 pulses

Sets zero servo bandwidth in units of one pulse. During zero servo control, the multi-function contact output ($H2-__ = "33"$) is closed until the number of pulses (or bandwidth) is completed. Then the contact output opens.

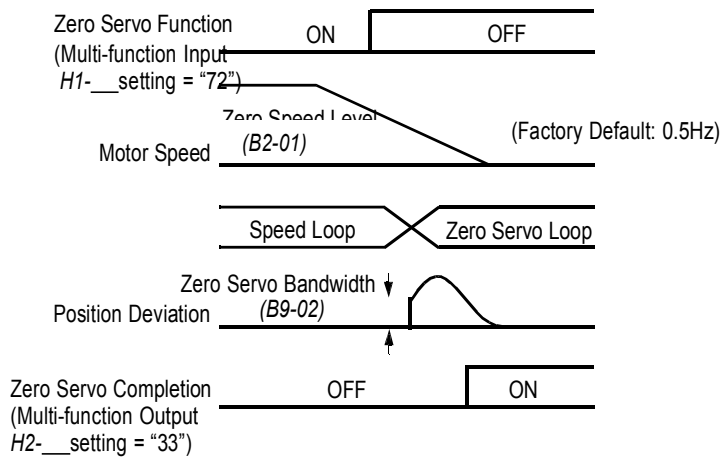

Figure 12 Timing Diagram of Zero Servo Function

Notes:

1. For multi-function contact input function selection, refer to parameters $H1-01$ to $H1-06$.
2. For multi-function contact output function selection, refer to parameters $H2-01$ to $H2-03$.
3. This function is only available during flux vector control ($A1-02 = "3"$).

C Tuning Parameters

C1 Accel/Decel

- C1-01 Acceleration time 1* *Accel Time 1*
- C1-02 Deceleration time 1* *Decel Time 1*
- C1-03 Acceleration time 2* *Accel Time 2*
- C1-04 Deceleration time 2* *Decel Time 2*
- C1-05 Acceleration time 3* *Accel Time 3*
- C1-06 Deceleration time 3* *Decel Time 3*
- C1-07 Acceleration time 4* *Accel Time 4*
- C1-08 Deceleration time 4* *Decel Time 4*

| | | | |
|---|---|---|---|
| Q | Q | Q | Q |
| Q | Q | Q | Q |
| B | B | B | B |
| B | B | B | B |
| A | A | A | A |
| A | A | A | A |
| A | A | A | A |
| A | A | A | A |

Setting Range: 0.00 to 6000.0s

Note: Setting range may be 0.00-600.0 or 0.0-6000.0 depending on the setting of parameter C1-10.

Factory Default: 10.0s

Acceleration time sets the time necessary for the output frequency to accelerate from 0Hz to maximum output frequency. Deceleration time sets the time necessary for the output frequency to decelerate from the maximum output frequency to 0Hz

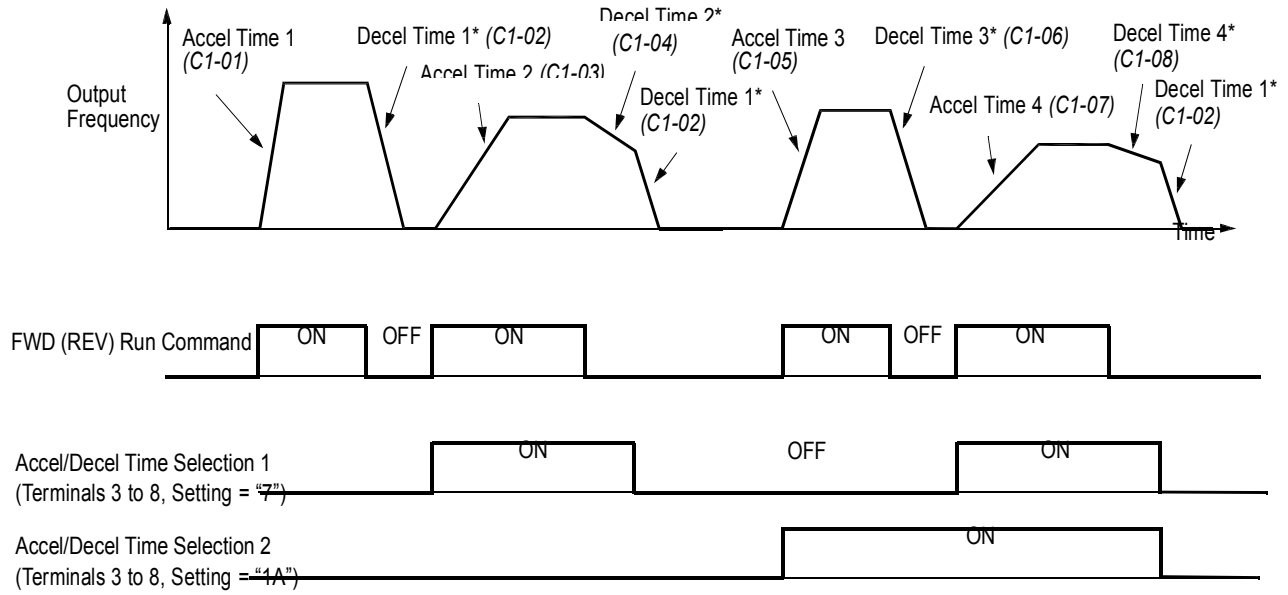

* When "deceleration to stop" is selected (B1-03 = "0")

Figure 13 Timing Diagram of Accel/Decel Time Adjustment

When any of the multi-function contact input selections (H1-01 to H1-06) are set to "7" and "1A", up to four accel/decel times can then be selected by opening or closing the appropriate accel/decel time selection commands (terminals 3 to 8).

| Accel/decel Time Selection 1 Multi-function Input Setting = "7" | Accel/decel Time Selection 2 Multi-function Input Setting = "1A" | Accel Time | Decel Time |
|--|---|------------|------------|
| Open or not set | Open or not set | C1-01 | C1-02 |
| Closed | Open or not set | C1-03 | C1-04 |
| Open or not set | Closed | C1-05 | C1-06 |
| Closed | Closed | C1-07 | C1-08 |

C1-09 Fast-Stop Time

Fast Stop Time

| | | | |
|---|---|---|---|
| B | B | B | B |
|---|---|---|---|

Setting Range: 0.00 to 6000.0s
 Factory Default: 10.0s

Fast-stop time is enabled when:
 Multi-function contact input is set to fast-stop command (setting = "15"), and the contact closes.
 The default stopping method when a fault is detected is fast-stop.

C1-10 Accel/Decel Time Setting Unit

Acc/Dec Units

| | | | |
|---|---|---|---|
| A | A | A | A |
|---|---|---|---|

| Setting | Description |
|---------|--|
| 0 | Accel/decel time (C1-01 to C1-09) setting range is in units of 0.01 second. Accel/decel time setting range: 0.00 to 600.00s |
| 1 | Accel/decel time (C1-01 to C1-09) setting range is in units of 0.1 second. Accel/decel time setting range: 0.0 to 6000.0s (factory default) |

If any of the parameters C1-01 to C1-09 is set to 600.1 seconds or more, C1-10 cannot be set to “0”.

C1-11 Accel/Decel Time Switching Frequency Level

Acc/Dec SW Freq

| | | | |
|---|---|---|---|
| A | A | A | A |
|---|---|---|---|

Setting Range: 0.0 to 400.0Hz
Factory Default: 0.0Hz

Accel/decel times can be changed automatically, without using the multi-function contact inputs. Use accel/decel times set in parameters C1-01 and C1-02 when output frequency > C1-11. Use accel/decel times set in parameters C1-07 and C1-08 when output frequency < C1-11. When multi-function contact inputs are set for accel/decel selection, this command has priority over automatic change of accel/decel.

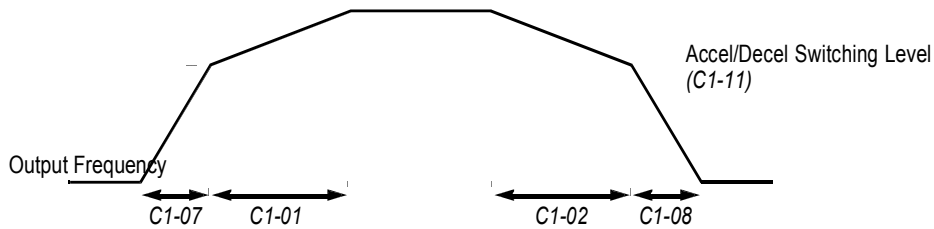

Figure 14 Accel/Decel Switching Level Adjustment

C2 S-Curve Accel/Decel

An S-curve pattern is used to reduce shock and provide smooth transitions during machine acceleration and deceleration. S-curve characteristic time is the time from the output frequency to the set accel/ decel time.

C2-01 S-Curve Time at Acceleration Start

SCrv Acc @ Start

C2-02 S-Curve Time at Acceleration End

SCrv Acc @ End

C2-03 S-Curve Time at Deceleration Start

SCrv Dec @ Start

C2-04 S-Curve Time at Deceleration End

SCrv Dec @ End

| | | | |
|---|---|---|---|
| A | A | A | A |
| A | A | A | A |
| A | A | A | A |
| A | A | A | A |

Setting Range: 0.00 to 2.50s
Factory Default: 0.20s

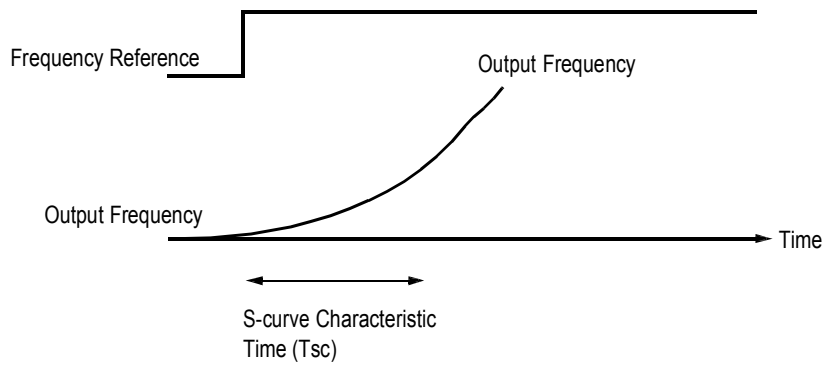

Figure 15 S-curve Characteristic Timing Diagram

The following figure shows FWD/REV run switching during deceleration to stop.

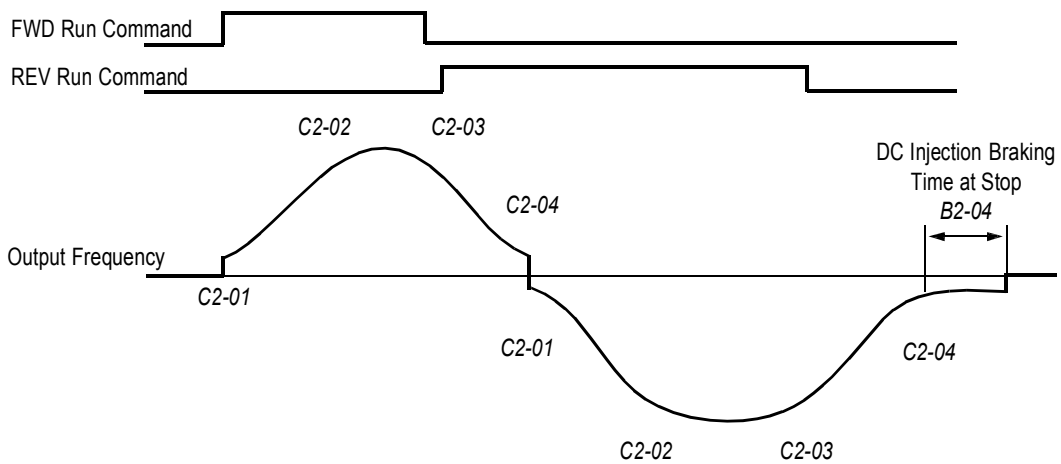

Figure 16 S-curve Characteristics - FWD/REV Operation

Time to accelerate from the minimum frequency to the maximum frequency (total acceleration) = $C1-___ + (C2-01 + C2-02)/2$

C3 Motor Slip Compensation

As the load becomes larger, the motor speed is reduced and motor slip increases. The slip compensation function keeps the motor speed constant even under varying load conditions.

C3-01 Slip Compensation Gain

Slip Comp Gain

| | | | |
|---|----|---|---|
| B | -- | B | B |
|---|----|---|---|

Setting Range: 0.0 to 2.50
 Factory Default: 1.0

This function controls the output frequency in response to the load's torque demand. Increase the set value in one tenth (0.1) increments when operating at low speeds; decrease the set value as the motor speed increases.

During flux vector control, this gain compensates for motor slip causes by changes in temperature. Normally, this setting does not have to be modified.

Note: Default factory setting will be 0.0 when parameter A1-02=0 [V/F mode]. When parameter A1-02=2 [Open Loop Vector] or 3 [Flux Vector] the default factory setting will be 1.0.

C3-02 Slip Compensation Primary Delay Time

Slip Comp Time

| | | | |
|---|----|---|----|
| A | -- | A | -- |
|---|----|---|----|

Setting Range: 0 to 10000ms
 Factory Default: 200ms

Adjust the slip compensation delay time when motor speed is unstable or speed response is slow. Increase the set value in 10ms increments when operating at low speeds; decrease the set value as the motor speed increases.

C3-03 Slip Compensation Limit

Slip Comp Limit

| | | | |
|---|----|---|----|
| A | -- | A | -- |
|---|----|---|----|

Sets the slip compensation limit as a percentage of motor rated slip (E2-02).

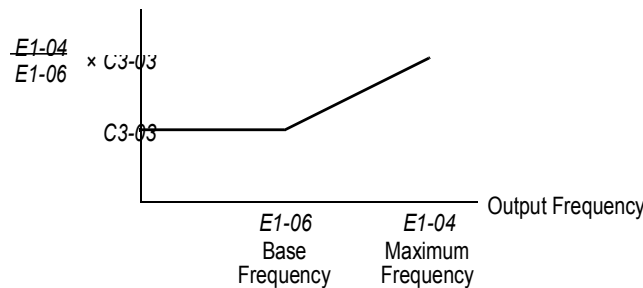

Figure 17 Slip Compensation Limit Adjustment

C3-04 Slip Compensation During Regeneration

Slip Comp Regen

| | | | |
|---|----|---|----|
| A | -- | A | -- |
|---|----|---|----|

| Setting | Description |
|---------|---|
| 0 | Slip compensation disabled during regeneration (<i>factory default</i>) |
| 1 | Slip compensation enabled during regeneration |

C3-05 Flux Calculation Method

Flux Select

| | | | |
|----|----|---|----|
| -- | -- | A | -- |
|----|----|---|----|

Parameter C3-05 determines if the motor torque characteristic is based on output frequency or motor speed.

| Setting | Description |
|---------|--|
| 0 | Slip Included Motor torque characteristic is based on frequency. (<i>factory default</i>) |
| 1 | Slip Excluded Motor torque characteristic is based on motor speed. |

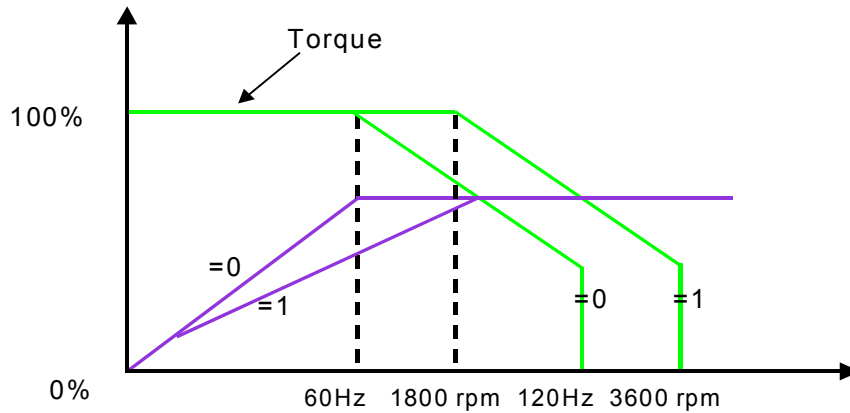

When running the motor only in the constant torque region, leave parameter C3-05 set to 0 for the best performance.

When running the motor in the constant horsepower region, set parameter C3-05 to 1 because the larger flux will result in better motor stability.

C3-06 Output Voltage Limit Operation Selection <1110> Output V Limit

| | | | |
|---|----|---|---|
| - | -- | A | A |
|---|----|---|---|

| Setting | Description |
|---------|---|
| 0 | Disabled (<i>factory default</i>) When this parameter is "0" slip compensation will be disabled when the motor is operating above its base speed. The motor voltage will not be reduced above base speed. |
| 1 | Enabled Open Loop Vector Mode: When this parameter is set to "1" the motor voltage will be reduced slightly when the motor is operating above 90% base speed. Slip Compensation is enabled. Speed control accuracy is improved. This may prevent speed instabilities due to motor voltage saturation. This setting may improve speed regulation however motor torque/amp will be reduced by up to 10% due to motor voltage reduction above base speed. Flux Vector Mode: Torque linearity is improved. |

C4 Torque Compensation

Motor torque can be adjusted by changing the V/f pattern (E1-03) or by adjusting the torque compensation gain. For details on setting the V/f pattern, see section E1, **V/f Pattern Adjustment**.

Parameters C4-03, C4-04 and C4-05 are added for the OLV mode to help improve starting/breakaway response. Individual torque compensation settings are possible for forward (C4-03) and reverse (C4-04). The delay time (C4-05) is the time for which the internal torque reference will be increased. This torque compensation is much like inputting an analog torque reference via an analog input.

C4-01 Torque Compensation Gain

Torq Comp Gain

| | | | |
|---|---|---|----|
| B | B | B | -- |
|---|---|---|----|

The motor torque requirement changes according to load conditions. Full-range automatic torque boost adjusts the voltage of the V/f pattern according to the required torque. The FST-800 Series automatically adjusts the voltage during constant-speed operation as well as during acceleration.

The required torque is calculated by the inverter. This ensures tripless operation and power savings.

$$\text{Output voltage} = \text{Torque compensation gain} \times \text{Required torque}$$

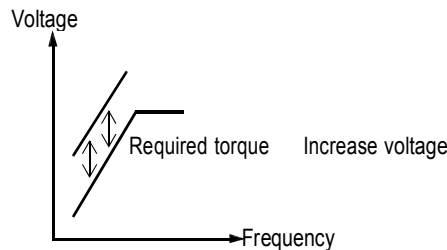

Figure 18 Torque Characteristics

Normally, no adjustment is necessary for torque compensation gain. When more torque is needed, increase the torque compensation gain in one tenth (0.1) increments. When the wiring distance between the inverter and the motor is long, or when the motor generates excessive vibration, decrease the torque compensation gain.

Increasing torque compensation gain increases motor torque, but an excessive increase may cause the following:

- Inverter fault trips due to motor overexcitation
- Motor overheat or excessive vibration

C4-02 Torque Compensation Time Constant

Torq Comp Time

| | | | |
|---|---|---|----|
| A | A | A | -- |
|---|---|---|----|

Setting Range: 0 to 10000ms

Factory Default: 20ms

Increase the torque compensation time constant in 10ms increments when the motor output current is unstable, and decrease this value when speed response is slow.

Note: When A1-02=2 [Open Loop Vector] the factory default setting is 20 ms. When A1-02=1 or 3 [V/F or V/F w/PG] factory default setting is 200 ms.

C4-03 Forward Torque Compensation Value at Start<1110> start

F TorqCmp @

| | | | |
|----|----|---|----|
| -- | -- | A | -- |
|----|----|---|----|

Setting Range: 0.0 to 200.0%

Factory Default: 0.0

This parameter may improve the motor performance during start. This feature functions only when starting a motor. Torque reference and motor flux can be ramped up quickly to improve speed response during start. A setting of 0.0 disables this feature.

C4-04 Reverse Torque Compensation Value at Start<1110> start

R TorqCmp @

| | | | |
|----|----|---|----|
| -- | -- | A | -- |
|----|----|---|----|

Setting Range: 0.0 to 200.0%

Factory Default: 0.0

This parameter may improve the motor performance during start. This feature functions only when starting a motor. Torque reference and motor flux can be ramped up quickly to improve speed response during start. A setting of 0.0 disables this feature.

C4-05 Torque Compensation Time Constant@Start<1110>

TorqCmp Delay T

| | | | |
|----|----|---|----|
| -- | -- | A | -- |
|----|----|---|----|

Setting Range: 0 to 200 ms

Factory Default: 1 ms

This parameter functions with C4-03 and C4-04. This parameter is the time delay that will be applied to the Torque Compensation parameters C4-03 and C4-04. A setting of less than 4 milliseconds (ms) causes this filter to be disabled.

C5 ASR Tuning

The automatic speed regulator (ASR) provides optimum performance during changes in motor speed or load, when speed feedback is provided.

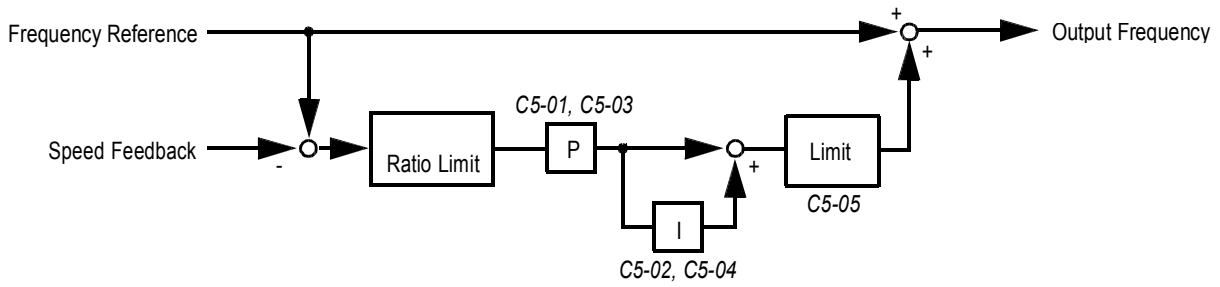

Figure 19 ASR Block Diagram (V/f Control with PG Feedback)

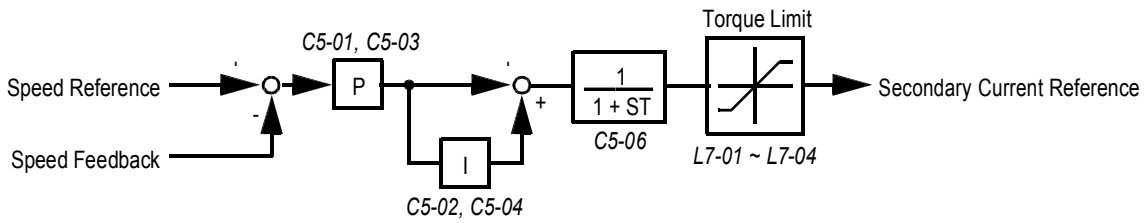

Figure 20 ASR Block Diagram (Flux Vector Control)

C5-01 ASR Proportional Gain 1

ASR P Gain 1

| | | | |
|----|---|----|---|
| -- | B | -- | B |
|----|---|----|---|

Setting Range: 0.00 to 300.00
 Factory Default: 20.00

The ASR proportional gain 1 adjusts the speed in response to speed deviation, and softens the effect of changes in load. Speed response increases as the proportional gain is increased. However, the load may become unstable if the ASR proportional gain is set too high.

Note: When parameter A1-02=1 [V/f w/PG] the factory default setting is 0.20. When parameter A1-02=3 the factory default setting is 20.00.

C5-02 ASR Integral Time 1

ASR I Time 1

| | | | |
|----|---|----|---|
| -- | B | -- | B |
|----|---|----|---|

Setting Range: 0.000 to 10.000s
 Factory Default: 0.500s

The ASR integral time 1 adjusts the inverter's response time to changes in load. Speed response increases as the integral time is decreased. However, the load may become unstable if the ASR integral time is set too low.

Note: When A1-02=1 [V/f w/PG] the factory default setting is .200. When A1-02=3 factory default setting is 0.500

When A1-02=1 [V/f w/PG] factory default setting is 0.20. When A1-02=3 factory default setting is 20.00.
 When A1-02=1 [V/f w/PG] factory default setting is 0.200. When A1-02=3 factory default setting is 0.500
 When A1-02=1 [V/f w/PG] factory default setting is 0.02. When A1-02=3 factory default setting is 20.00.

C5-03 ASR Proportional Gain 2

ASR P Gain 2

| | | | |
|----|---|----|---|
| -- | B | -- | B |
|----|---|----|---|

Setting Range: 0.00 to 300.00
 Factory Default: 20.00

The ASR proportional gain 2 is an additional proportional gain adjustment that can be enabled by a multi-function contact input (H1-__ = "77").

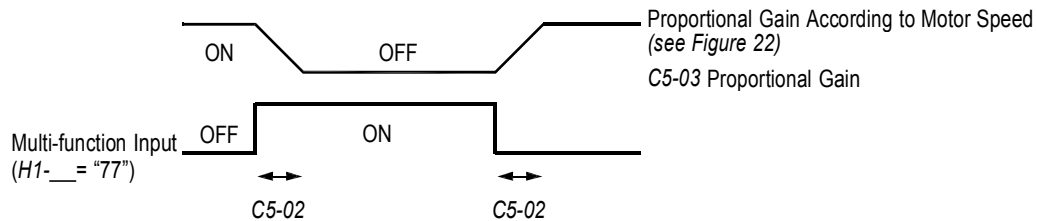

Figure 21 ASR Multi-function Input Timing Diagram

Note: When parameter A1-02=1 [V/f w/PG] factory default setting is .02. When A1-02=3 the factory default setting is 20.00.

C5-04 ASR Integral Time 2

ASR I Time 2

| | | | |
|---|---|----|---|
| - | B | -- | B |
|---|---|----|---|

Setting Range: 0.000 to 10.000s
 Factory Default: 0.500s

The ASR integral time 2 is an additional integral time adjustment.

C5-05 ASR Limit

ASR Limit

| | | | |
|----|---|----|----|
| -- | A | -- | -- |
|----|---|----|----|

Sets ASR frequency compensation limit as a percentage of maximum output frequency (E1-04). This function is enabled when V/f control with PG feedback is selected as the control method (A1-02).

C5-06 ASR Output Primary Delay Time

ASR Delay Time

| | | | |
|---|----|----|---|
| - | -- | -- | A |
|---|----|----|---|

Setting Range: 0.000 to 0.500s
 Factory Default: 0.004s

Mechanical backlash in an application causes secondary current (I₂) reference variations in the motor's rotor. This condition can prevent the adjustment of ASR parameters. The output delay time constant is used to control these secondary current (I₂) reference variations.

C5-07 ASR Switching Frequency Level

ASR Gain SW Freq

| | | | |
|----|----|----|---|
| -- | -- | -- | A |
|----|----|----|---|

Setting Range: 0.0 to 400.0Hz
 Factory Default: 0.0Hz

Sets frequency to change ASR proportional gain and integral time constant in units of 0.1Hz when flux vector control is selected.

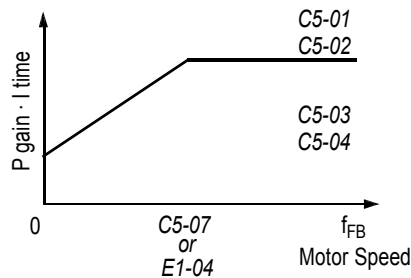

$$f_{FB} = \frac{P \cdot N}{120}$$

where:
 P = Number of Motor Poles
 N = Motor RPM

* When C5-07="0", proportional gain 1 (C5-01) and integral time 1 (C5-02) are selected.

Figure 22 ASR Switching Frequency Level

Notes:

1. When C5-07="0", proportional gain 1 (C5-01) and integral time 1 (C5-02) are selected.
2. During V/f control with PG feedback (A1-02="1"), the frequency switching level becomes the maximum output frequency (E1-04).

C5-08 ASR Integral Limit

ASR I Limit

| | | | |
|---|----|----|---|
| - | -- | -- | A |
|---|----|----|---|

Setting Range: 0 to 400%
 Factory Default: 400%

.Parameter C5-08 adjusts the amount of Integral control of the automatic speed regulator in the Closed Loop Flux Vector control mode. Setting parameter C5-08 to zero will make the ASR control proportional. Setting C5-08 to 400% will make the ASR control proportional and integral.

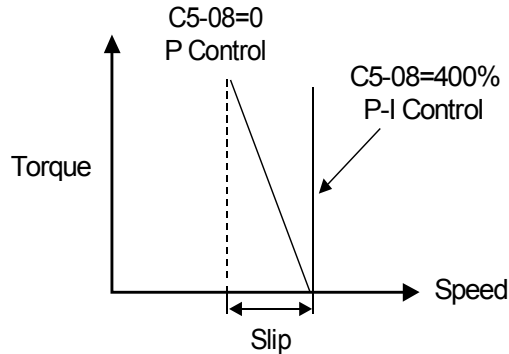

C6 Carrier Frequency

This function sets the inverter output transistor switching frequency (carrier frequency). Increase the carrier frequency to reduce motor noise and decrease it to reduce leakage current.

C6-01 Carrier Frequency Upper Limit

CarrierFreq Max

| | | | |
|---|---|----|----|
| B | B | B | B |
| A | A | -- | -- |

C6-02 Carrier Frequency Lower Limit

CarrierFreq Min

Setting Range: 0.4 to 15.0kHz
 Factory Default: 15.0Hz*

For constant carrier frequency operation, set the gain (C6-03) to "0", and set the upper limit (C6-01) and lower limit (C6-02) to the same value.

* Factory defaults vary depending on drive rating. See the following table for more details:

Carrier Frequency Factory Defaults

| Model CIMR- G5U | Upper Limit C6-01 Setting | Lower Limit C6-02 Setting | Gain C6-03 Setting | Model CIMR- G5U | Upper Limit C6-01 Setting | Lower Limit C6-02 Setting | Gain C6-03 Setting |
|-----------------------|---------------------------------|---------------------------------|--------------------------|-----------------------|---------------------------------|---------------------------------|--------------------------|
| 230 | | | | | | | |
| 20P4 | 15.0 | 15.0 | 0 | 2015 | 15.0 | 15.0 | 0 |
| 20P7 | 15.0 | 15.0 | 0 | 2018 | 15.0 | 15.0 | 0 |
| 21P5 | 15.0 | 15.0 | 0 | 2022 | 10.0 | 10.0 | 0 |
| 22P2 | 15.0 | 15.0 | 0 | 2030 | 10.0 | 10.0 | 0 |
| 23P7 | 15.0 | 15.0 | 0 | 2037 | 10.0 | 10.0 | 0 |
| 25P5 | 15.0 | 15.0 | 0 | 2045 | 10.0 | 10.0 | 0 |
| 27P5 | 15.0 | 15.0 | 0 | 2055 | 10.0 | 10.0 | 0 |
| 2011 | 15.0 | 15.0 | 0 | 2075 | 10.0 | 10.0 | 0 |
| - | - | - | - | 2090 | 2.0 | 2.0 | 0 |
| - | - | - | - | 2185 | 2.0 | 2.0 | 0 |
| 460 | | | | | | | |
| 40P4 | 15.0 | 15.0 | 0 | 4022 | 8.0 | 8.0 | 0 |
| 40P7 | 15.0 | 15.0 | 0 | 4030 | 8.0 | 8.0 | 0 |
| 41P5 | 15.0 | 15.0 | 0 | 4037 | 6.0 | 6.0 | 0 |
| 42P2 | 15.0 | 15.0 | 0 | 4045 | 6.0 | 6.0 | 0 |
| 43P7 | 15.0 | 15.0 | 0 | 4055 | 6.0 | 6.0 | 0 |
| 44P0 | 15.0 | 15.0 | 0 | 4075 | 6.0 | 6.0 | 0 |
| 45P5 | 15.0 | 15.0 | 0 | 4090 | 5.0 | 5.0 | 0 |
| 47P5 | 12.5 | 12.5 | 0 | 4110 | 5.0 | 5.0 | 0 |
| 4011 | 12.5 | 12.5 | 0 | 4132 | 5.0 | 5.0 | 0 |
| 4015 | 10.0 | 10.0 | 0 | 4160 | 5.0 | 5.0 | 0 |
| 4018 | 10.0 | 10.0 | 0 | 4185 | 2.0 | 2.0 | 0 |
| - | - | - | - | 4220 | 2.0 | 2.0 | 0 |
| - | - | - | - | 4300 | 2.0 | 2.0 | 0 |
| 575 | | | | | | | |
| 51P5 | 10.0 | 10.0 | 0 | 5030 | 10.0 | 10.0 | 0 |
| 52P2 | 10.0 | 10.0 | 0 | 5037 | 10.0 | 10.0 | 0 |
| 53P7 | 10.0 | 10.0 | 0 | 5045 | 10.0 | 10.0 | 0 |
| 55P5 | 10.0 | 10.0 | 0 | 5055 | 8.0 | 8.0 | 0 |
| 57P5 | 10.0 | 10.0 | 0 | 5075 | 2.0 | 1.0 | 36 |
| 5011 | 10.0 | 10.0 | 0 | 5090 | 2.0 | 1.0 | 36 |
| 5015 | 10.0 | 10.0 | 0 | 5110 | 2.0 | 1.0 | 36 |
| 5018 | 10.0 | 10.0 | 0 | 5160 | 2.0 | 1.0 | 36 |
| 5022 | 10.0 | 10.0 | 0 | | | | |

C6-03 Carrier Proportional Gain

Setting Range: 0 to 99
 Factory Default: 0

CarrierFreq Gain

| | | | |
|---|---|----|----|
| A | A | -- | -- |
|---|---|----|----|

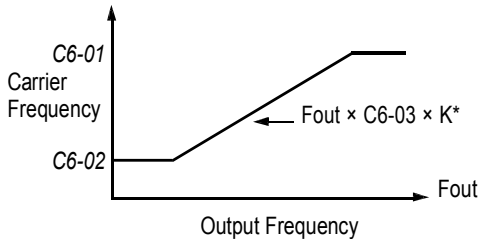

* K varies depending on the carrier frequency upper limit (C6-01):

| | |
|--|---------|
| $C6-01 > 10.0\text{kHz}$ | $K = 3$ |
| $10.0\text{kHz} > C6-01 > 5.0\text{kHz}$ | $K = 2$ |
| $C6-01 < 5.0\text{kHz}$ | $K = 1$ |

Figure 23 Carrier Frequency Setting

Note: An OPE11 fault occurs if either of the following conditions is present:

1. $C6-03 > 6\text{kHz}$ and $C6-02 > C6-01$
2. $C6-01 > 5\text{kHz}$ and $C6-02 \leq 5\text{kHz}$

C7 Hunting Prevention

Occasionally, in an application, resonance between the internal control system and the mechanical system causes current instability. This instability is called hunting, and may cause the machine to vibrate at lower speeds (up to 30Hz). The hunting prevention function monitors the motor flux and uses a special control circuit to “smooth out” any peaks in the output current waveform.

C7-01 Hunting Prevention Selection

Hunt Prev Select

| | | | |
|---|---|----|----|
| A | A | -- | -- |
|---|---|----|----|

Enables the hunting prevention function in V/f control mode.

| Setting | Description |
|---------|--|
| 0 | Hunting prevention is disabled. |
| 1 | Hunting prevention is enabled (factory default). |

C7-02 Hunting Prevention Gain

Hunt Prev Gain

| | | | |
|---|---|----|----|
| A | A | -- | -- |
|---|---|----|----|

Setting Range: 0.00 to 2.50
 Factory Default: 1.00

Sets hunting prevention gain in units of 0.01. When hunting is present while driving a light load, increase the set value in one tenth (0.1) increments. When the motor vibrates or stalls while driving a heavy load, decrease the set value.

C8 Factory Tuning

This section describes parameters not normally accessed by the user, but which may require adjustment.

C8-08 Automatic Frequency Regulator Adjustment *AFR Gain*

| | | | |
|----|----|---|----|
| -- | -- | A | -- |
|----|----|---|----|

Setting Range: 0.00 to 10.00

Factory Default: 1.00

Sets AFR gain in units of 0.01. When hunting is present during open loop vector control, decrease the set value in one tenth (0.1) increments. If the speed or torque response is slow, increase the set value.

C8-09 Automatic Frequency Regulator Time Constant *AFR Time*

| | | | |
|----|----|---|----|
| -- | -- | A | -- |
|----|----|---|----|

Setting Range: 0 to 2000 milliseconds

Factory Default: 50 milliseconds

Parameter C8-09 sets the AFR (automatic frequency regulator) time. Adjusting C8-09 will increase or decrease the AFR frequency response, when the load changes.

If the motor is unstable, increase the set value.

If the speed response is slow, decrease the set value.

C8-30 Carrier Frequency Selection During Auto-tuning *Carrier in Tune*

| | | | |
|----|----|---|---|
| -- | -- | A | A |
|----|----|---|---|

During normal auto-tuning, the inverter is tuned while running at a carrier frequency of 2kHz. This parameter allows the user to specify the inverter carrier frequency during auto-tuning. Adjustment may be necessary when using a spindle motor with low inductance.

| Setting | Description |
|---------|--|
| 0 | Carrier frequency during auto-tuning is 2kHz (<i>factory default</i>). |
| 1 | Carrier frequency during auto-tuning is set by <i>C6-01</i> . |
| 2 | Carrier frequency is 5kHz. Except for 185-300 kW which is 2.5 kHz |

D Reference Parameters

D1 Preset References

| | |
|---|--------------------|
| <i>D1-01 Preset Frequency Reference 1</i> | <i>Reference 1</i> |
| <i>D1-02 Preset Frequency Reference 2</i> | <i>Reference 2</i> |
| <i>D1-03 Preset Frequency Reference 3</i> | <i>Reference 3</i> |
| <i>D1-04 Preset Frequency Reference 4</i> | <i>Reference 4</i> |
| <i>D1-05 Preset Frequency Reference 5</i> | <i>Reference 5</i> |
| <i>D1-06 Preset Frequency Reference 6</i> | <i>Reference 6</i> |
| <i>D1-07 Preset Frequency Reference 7</i> | <i>Reference 7</i> |
| <i>D1-08 Preset Frequency Reference 8</i> | <i>Reference 8</i> |

| | | | |
|---|---|---|---|
| Q | Q | Q | Q |
| Q | Q | Q | Q |
| Q | Q | Q | Q |
| Q | Q | Q | Q |
| B | B | B | B |
| B | B | B | B |
| B | B | B | B |
| B | B | B | B |

Setting Range: 0.0 to 400.0Hz
 Factory Default: 0.0Hz

Up to 9 preset speed references (including jog) can be set through

multi-function contact input function selections. When using the multi-step speed references, set the reference selection (*B1-01*) to "0", and set terminal 16 selection (*H3-05*) to "1F". See the following table for programming preset speed references.

| Terminal 5 <i>H1-03 = "3"</i> | Terminal 6 <i>H1-04 = "4"</i> | Terminal 7 <i>H1-05 = "5"</i> | Terminal 8 <i>H1-06 = "6"</i> | Speed Reference |
|----------------------------------|----------------------------------|----------------------------------|----------------------------------|---|
| Open | Open | Open | Open | Speed Reference 1 - Set Reference Source (<i>B1-01</i>) to "0". |
| Closed | Open | Open | Open | Speed Reference 2 - Set Terminal 16 Selection (<i>H3-05</i>) to "1F". |
| Open | Closed | Open | Open | Speed Reference 3 |
| Closed | Closed | Open | Open | Speed Reference 4 |
| Open | Open | Closed | Open | Speed Reference 5 |
| Closed | Open | Closed | Open | Speed Reference 6 |
| Open | Closed | Closed | Open | Speed Reference 7 |
| Closed | Closed | Closed | Open | Speed Reference 8 |
| Closed | Closed | Closed | Closed | Jog Speed Reference |

D1-09 Jog Frequency Reference

JOG Reference

| | | | |
|---|---|---|---|
| Q | Q | Q | Q |
|---|---|---|---|

Setting Range: 0.0 to 400.0Hz

Factory Default: 0.0Hz

The jog frequency reference can be set in this parameter. Depress the JOG key on the digital operator, or close terminal 7, to use this function. The jog command always has priority over other reference commands. When using the multi-step speed references, change the jog command from terminal 7 to terminal 8 (*H1-06* = "6").

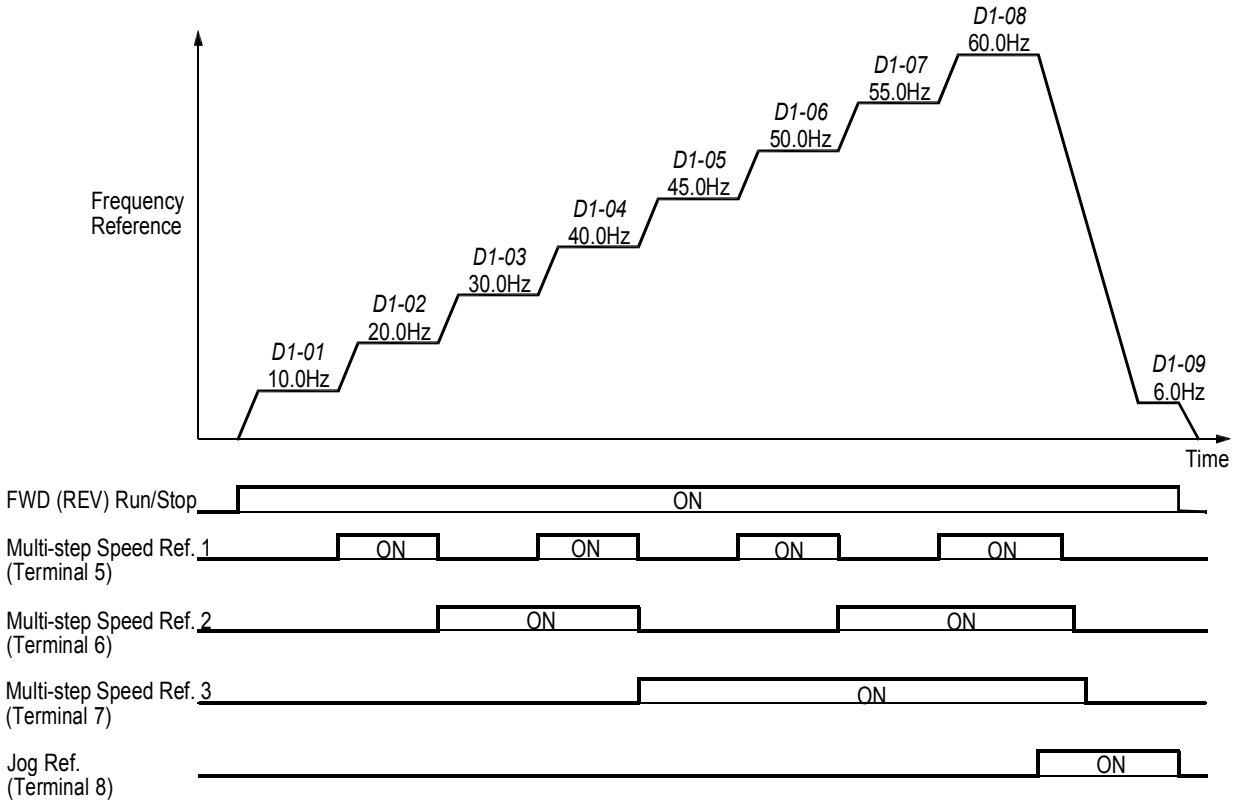

Figure 24 Multi-step Speed Operation - Timing Diagram

Note: Setting units for *D1-01* to *D1-09* are dependent upon the setting of digital operator display mode (*O1-03*). Possible setting units include Hz, percentage, RPM or engineering units. See section **O1, Monitor Selection**, on page 120 for more details.

D2 Reference Limits

D2-01 Frequency Reference Upper Limit

Ref Upper Limit

| | | | |
|---|---|---|---|
| B | B | B | B |
|---|---|---|---|

Setting Range: 0.0 to 110.0%
 Factory Default: 100.0%

The frequency reference upper limit is set as a percentage of the maximum output frequency (E1-04) in increments of 1%.

D2-02 Frequency Reference Lower Limit

Ref Lower Limit

| | | | |
|---|---|---|---|
| B | B | B | B |
|---|---|---|---|

Setting Range: 0.0 to 109.0%
 Factory Default: 100.0%

The frequency reference lower limit is set as a percentage of the maximum output frequency (E1-04) in increments of 1%. When a run command is input and the frequency reference is less than the lower limit, operation continues at the frequency reference lower limit. However, when the lower limit is set to less than the minimum output frequency (E1-09), operation discontinues.

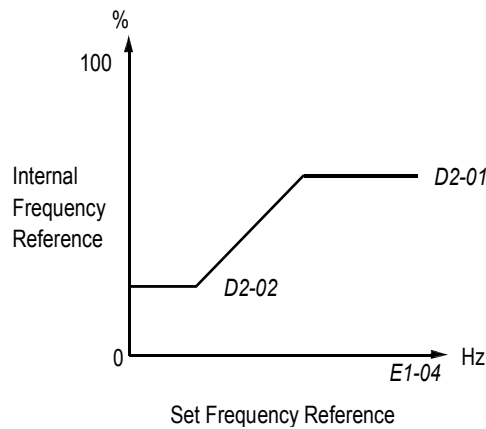

Figure 25 Setting Frequency Upper and Lower Limits

D3 Jump Frequencies

D3-01 Jump Frequency Reference1

Jump Freq 1

D3-02 Jump Frequency Reference2

Jump Freq 2

D3-03 Jump Frequency Reference1

Jump Freq 3

D3-04 Jump Frequency Reference Bandwidth

Jump Bandwidth

| | | | |
|---|---|---|---|
| B | B | B | B |
| B | B | B | B |
| B | B | B | B |
| B | B | B | B |

This function allows the prohibition or “jumping” of critical frequencies so that the motor can operate without resonant vibrations caused by some machine systems. This function is also used for dead-band control. Setting the value to 0.0Hz disables this function.

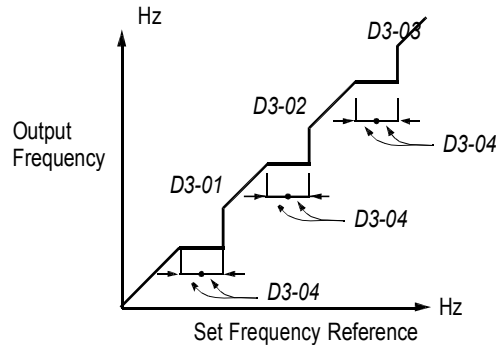

Figure 26 Jump Frequencies

D4 Sequence

D4-01 Hold Reference Memory Selection

MOP Ref Memory

| | | | |
|---|---|---|---|
| A | A | A | A |
|---|---|---|---|

Selects whether the held frequency during motor operated potentiometer (MOP) simulation operation is stored when operation is stopped (when power is removed or when the run command is removed).

| Setting | Description |
|---------|---|
| 0 | Held frequency during MOP operation not retained. If a stop command is given or if power is removed, the frequency reference is reset to 0Hz. If the inverter is still decelerating when the run command is restored, operation resumes at the frequency reference which the inverter has ramped down to (factory default). |
| 1 | Held frequency during MOP operation is retained. If a stop command is given, or if power is removed, operation resumes at the held frequency reference when run command is restored. |

Note: MOP operation is set using the multi-function contact input function selections (H1-01 to H1-06, setting = “10” and “11”). See section **H1, Digital Inputs**, on page 76 for more information.

D4-02 Trim Control Level

Trim Control Lvl

| | | | |
|---|---|---|---|
| A | A | A | A |
|---|---|---|---|

Setting Range: 0 to 100%
 Factory Default: 10%

Sets the motor operated pot or “trim” control level as a percentage of maximum output frequency in units of 1%. When trim control increase and decrease are selected as multi-function contact input functions (setting: H1-__ = “1C” and “1D”, respectively), the trim control level is added to or subtracted from the analog frequency reference, when each respective contact closes. This is useful in applications such as winders and unwinders, where speed compensation may be needed.

D5 Torque Control**D5-01 Torque Control Selection***Torq Control Sel*

| | | | |
|---|----|----|---|
| - | -- | -- | A |
|---|----|----|---|

Selects between speed and torque control during flux vector operation (*A1-03* = "3").

| Setting | Description |
|---------|--|
| 0 | Speed control enabled with torque limit (<i>factory default</i>) |
| 1 | Torque control enabled with speed limit |

Speed/torque control selection can also be made by using a multi-function contact input function selection (*H1-__* = "71").

D5-02 Torque Limit Primary Delay Time*Torq Ref Filter*

| | | | |
|---|----|----|---|
| - | -- | -- | A |
|---|----|----|---|

Setting Range: 0 to 1000ms

Factory Default: 0ms

Sets delay time constant for torque reference input in the torque control mode, in units of 1ms.

D5-03 Speed Limit Input Selection*Speed Limit Sel*

| | | | |
|---|----|----|---|
| - | -- | -- | A |
|---|----|----|---|

Sets speed limit selection in the torque control mode.

| Setting | Description |
|---------|--|
| 1 | Speed limit is the analog speed reference set by terminal 13 or 14 (<i>factory default</i>). |
| 2 | Speed limit is the reference set by <i>B1-01</i> . |

D5-04 Speed Limit Value*Speed Lmt Value*

| | | | |
|---|----|----|---|
| - | -- | -- | A |
|---|----|----|---|

Setting Range: -120 to 120%

Factory Default: 0%

Sets the speed limit value in the torque control mode as a percentage of the maximum output frequency, when *D5-03* = "2".

D5-05 Speed Limit Bias

Speed Lmt Bias

| | | | |
|----|----|----|---|
| -- | -- | -- | A |
|----|----|----|---|

Setting Range: 0 to 120%
 Factory Default: 10%

Sets the speed limit bias value in the torque control mode as a percentage of the maximum output frequency.

D5-06 Reference Delay Timer

Ref Hold Time

| | | | |
|----|----|----|---|
| -- | -- | -- | A |
|----|----|----|---|

Setting Range: 0 to 1000ms
 Factory Default: 0ms

Sets delay time from when the speed/torque control selection is made to when the control mode is actually changed, in units of 1ms.

Torque Control Operation

To select torque control, set torque selection (*D5-01*) to "1", or close the multi-function contact input set to speed/torque control (*H1-__* = "71") and set terminal 16 function selection to torque reference (*H3-05* = "13").

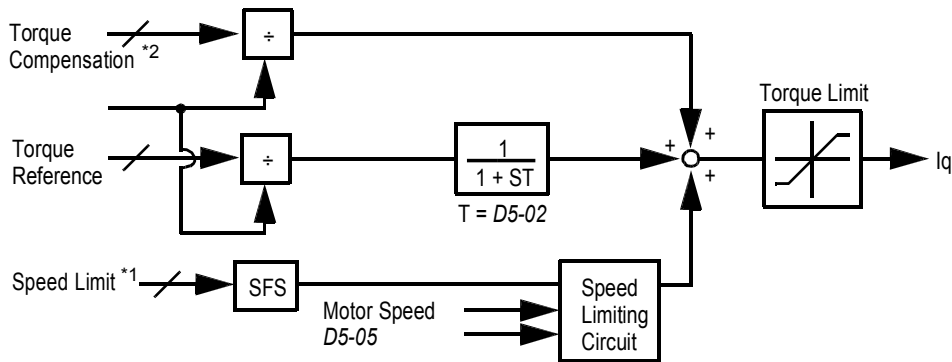

Figure 27 Torque Control Block Diagram

- *1: When speed limit selection (*D5-03*) is set to "1", the master frequency reference input from terminal 13 or 14 becomes the speed limit; when speed limit selection (*D5-03*) is set to "2", the set value of *D5-04* becomes the speed limit.
- *2: When terminal 14 function selection is set to torque compensation (*H3-09* = "14"), terminal 14 set value can be used as the torque compensation value.

When torque reference > 0 and speed limit > 0 (winder application sequence), the following sequence is activated:

- When $[-1 \times \text{speed limit bias } (D5-05)] < \text{motor speed} < [\text{speed limit} + D5-05]$, torque control is activated using the set torque reference.
- When motor speed $> [\text{speed limit} + D5-05]$, torque control is activated using the set torque reference.
- When motor speed $< [-1 \times D5-05]$, the speed limiting circuit outputs a positive torque reference to prevent the motor speed from increasing in the reverse direction.

Therefore, when torque reference > 0 and speed limit > 0 , the torque control range is:

$$[-1 \times D5-05] < \text{motor speed} < [\text{speed limit} + D5-05]$$

Refer to the following table for more details on the relationship between torque reference, speed limit and motor speed.

| | | Winder Control | | Unwinder Control | |
|-----------------------------|-------------------------|----------------|---------|------------------|---------|
| Configuration | | | | | |
| Direction of Motor Rotation | | Forward | Reverse | Forward | Reverse |
| Reference Polarity | Torque Reference (TREF) | + | - | - | + |
| | Speed Limit | + | - | + | - |
| | | | | | |

Speed/Torque Control Switching

When the FST-800 is set up for flux vector control ($A1-03 = "3"$), speed control or torque control can be selected "on the fly" by using the multi-function input speed/torque control selection command ($H1-__ = "71"$).

| Terminal No. | Parameter No. | Setting | Description |
|--------------|---------------|---------|--|
| 8 | $H1-06$ | 71 | Speed/torque control selection |
| 13 | $B1-01$ | 1 | Frequency reference selection (terminals 13, 14) |
| | $D5-03$ | 1 | Speed limit selection (terminals 13, 14) |
| 16 | $H3-05$ | 13 | Torque reference/speed limit |

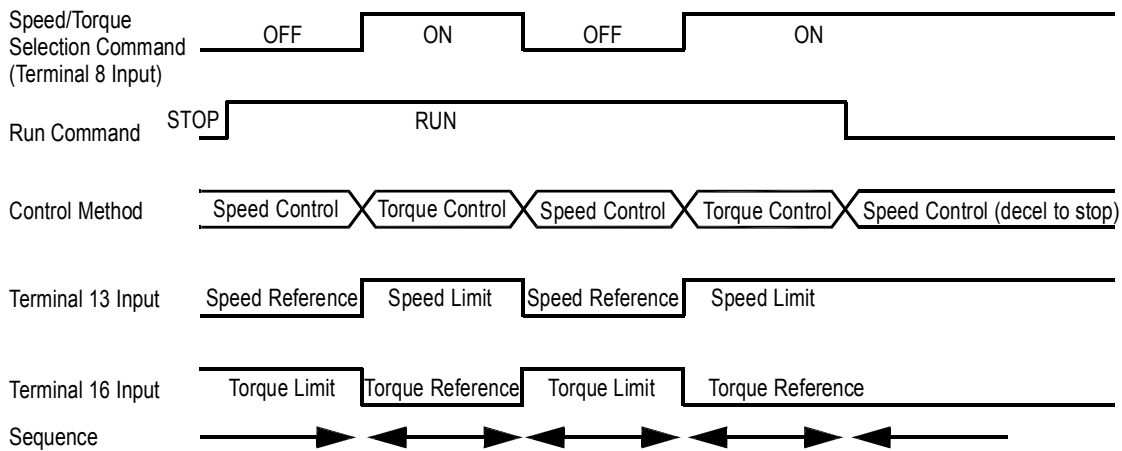

Figure 28 Speed/Torque Control Selection Timing Diagram

Sequence Description

When the speed/torque control selection contact is OFF, speed control is activated.

- Speed reference during speed control depends on the frequency reference selection ($B1-01$) setting. To use terminal 13 or 14 as the master frequency reference, set $B1-01$ to "1".
- Torque limit during speed control is the smaller of the absolute value of terminal 16 torque limit, or the values set in the torque limit parameters ($L7-01$ to $L7-04$).
- When a stop command is given during speed control, speed control is maintained and the smaller of the absolute value of terminal 16 torque limit, or the values set in the torque limit parameters ($L7-01$ to $L7-04$), is used as the torque limit. Then the motor decelerates to stop.

When the speed/torque control selection contact is ON, torque control is activated.

- Speed limit during torque control is the master frequency reference at terminal 13 or 14 when speed limit selection ($D5-03$) is set to "1", and is the speed limit value ($D5-04$) when $D5-03 = "2"$, regardless of the frequency reference selection ($B1-01$) setting.
- During torque control, the terminal 16 analog input value becomes the torque reference.

By giving a stop command during torque control, operation changes to speed control automatically, and the motor decelerates to stop. The torque limit during deceleration to stop becomes the values set in the torque limit parameters (*L7-01* to *L7-04*).

Note: The control mode actually changes after the speed/torque control selection command changes and after the reference delay timer (*D5-06*) elapses. The terminal 13 speed reference/speed limit and the terminal 16 torque limit/torque reference are stored in the inverter until the time set to *D5-06* elapses.

E Motor Parameters

E1 V/f Pattern

E1-01 Input Voltage

Input Voltage

| | | | |
|---|---|---|---|
| Q | Q | Q | Q |
|---|---|---|---|

Setting Range: 155 to 255V (230V class), 310 to 510V (460V class) 445 to 733 (575V class)<1110>

Factory Default: 230V, 460V, 575V <1110>

Sets the inverter input voltage in units of 1V.

E1-02 Motor Selection

Motor Selection

| | | | |
|---|---|---|---|
| Q | Q | Q | Q |
|---|---|---|---|

Select between fan-cooled, blower-cooled and vector/inverter duty motor types with this parameter.

| Setting | Description |
|---------|--|
| 0 | Fan-cooled motor characteristics (<i>factory default</i>) |
| 1 | Blower-cooled or TENV motor characteristics This setting allows 120% motor current at and above 5.6 Hz continuously, and allows 100% motor current at 0 Hz continuously (w/ linear in between). |
| 2 | Vector/inverter duty motor <1110> This setting allows 120% motor current at all frequencies. |

E1-03 V/f Pattern Selection

V/f Selection

| | | | |
|---|---|---|---|
| Q | Q | Q | Q |
|---|---|---|---|

Choose a preset V/f pattern for operation in V/f modes only. It may be necessary to change the V/f pattern when using a high-speed motor, or when special torque adjustment is required in the application.

Set values 0 to E: preset V/f pattern can be selected

F: custom V/f pattern can be set (*factory default*)

Preset V/f patterns are automatically scaled by the input voltage value set in parameter *E1-01*. Set the V/f pattern according to the applications described in the table on the following page:

Preset V/f Patterns

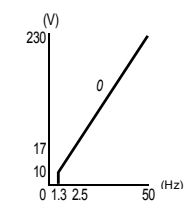
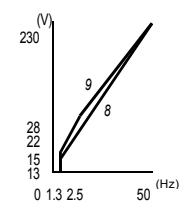
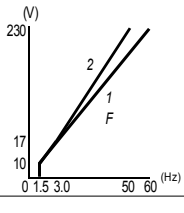
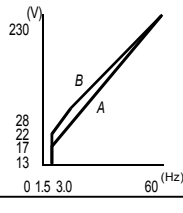
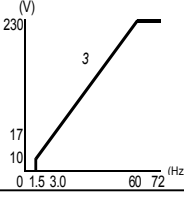
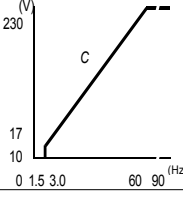
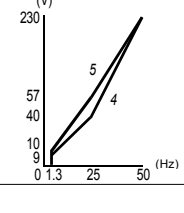
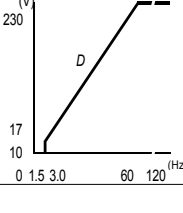
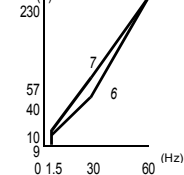
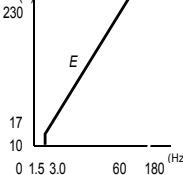
| Specifications | | E1- | V/f Pattern *1 | Specifications | | E1-03 | V/f Pattern *1 |
|-----------------|-----------------|------------------------|---|-------------------------|-----------------------------|-----------------------------|---|
| General-purpose | 50Hz | 0 |  | High Starting Torque *2 | 50Hz | High Starting Torque 1 8 |  |
| | | | | | High Starting Torque 2 9 | | |
| | 60Hz Saturation | 1 F |  | | 60Hz | High Starting Torque 1 A |  |
| | 50Hz Saturation | 2 | | | High Starting Torque 2 B | | |
| | 72Hz | 3 |  | | 90Hz | C |  |
| Variable Torque | 50Hz | Variable Torque 1 4 |  | High Speed Operation | 120Hz | D |  |
| | | Variable Torque 2 5 | | | | | |
| | 60Hz | Variable Torque 1 6 |  | | 180Hz | E |  |
| | | Variable Torque 2 7 | | | | | |

Notes:

- The following conditions must be considered when selecting a V/f pattern:
 - The voltage and frequency characteristics of the motor.
 - The maximum speed of the motor.
- Select a high starting torque V/f pattern only under the following conditions:
 - The wiring distance is long - 492 ft. (150m) and above.
 - Large voltage drop at start-up.
 - AC reactor is connected to the inverter's input or output.
- Voltage in preset patterns is doubled for 460V class inverters. The 575V patterns are 2.5 times the 230V patterns.

Custom V/f Pattern

Set up a custom V/f pattern by setting parameter E1-03 to "F", and then setting the values in parameters E1-04 to E1-13.

E1-04 Maximum Frequency

E1-05 Maximum Voltage

E1-06 Motor Base Frequency

E1-07 Middle Output Frequency A

E1-08 Middle Output Voltage A

E1-09 Minimum Output Frequency

E1-10 Minimum Output Voltage

E1-11 Middle Output Frequency B

E1-12 Middle Output Voltage B

E1-13 Motor Base Voltage

Max Frequency

Max Voltage

Base Frequency

Mid Frequency A

Mid Voltage A

Min Frequency

Min Voltage

Mid Frequency B

Mid Voltage B

Base Voltage

| | | | |
|------|-----|---|---|
| Q | Q | Q | Q |
| Q | Q | Q | Q |
| Q | Q | Q | Q |
| Q | Max | A | |
| MidB | Q | A | |
| Q | Q | Q | A |
| Q | Q | A | |
| A | A | A | A |
| A | A | A | A |
| A | A | Q | Q |

Be sure to satisfy the following conditions for setting parameters E1-04 to E1-13:

E1-09 E1-07 E1-06 E1-11 E1-04

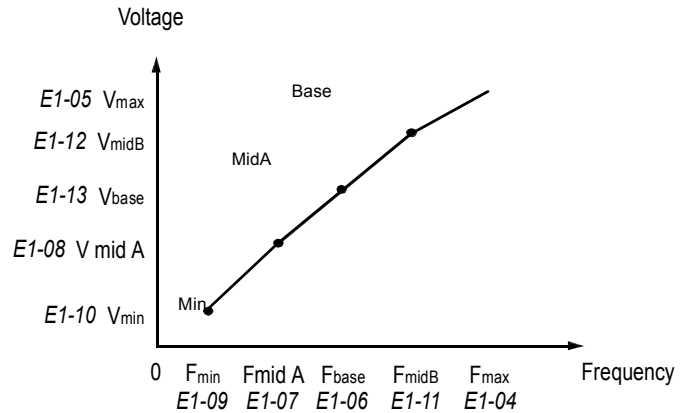

Figure 28 Custom V/f Pattern Setting

* For 460V class units, the value is twice that of 230V class units. For 575V class units the value is 2.5 times the 230V value.

Increasing the voltage in the V/f pattern increases motor torque. However, when setting a custom V/f pattern, increase the voltage gradually while monitoring the motor current, to prevent:

- Inverter fault trips as a result of motor overexcitation
- Motor overheat or excessive vibration

V/F Pattern for Inverter Capacity 0.4 ~ 1.5kW for 200V Class

| Parameter No. | Name | Unit | Factory Setting | | | | | | | |
|---------------|-------------------------------|------|-----------------|-------|-------|-------|-------|-------|-------|-------|
| | | | 0 | 1 | 2 | 3 | 4 | 5 | 6 | 7 |
| E1-03 | V/f Pattern Selection | — | 0 | 1 | 2 | 3 | 4 | 5 | 6 | 7 |
| E1-04 | Max. Output Frequency | Hz | 50.0 | 60.0 | 60.0 | 72.0 | 50.0 | 50.0 | 60.0 | 60.0 |
| E1-05 | Max. Voltage | V | 230.0 | 230.0 | 230.0 | 230.0 | 230.0 | 230.0 | 230.0 | 230.0 |
| E1-06 | Max. Voltage Frequency | Hz | 50.0 | 60.0 | 50.0 | 60.0 | 50.0 | 50.0 | 60.0 | 60.0 |
| E1-07 | Mid. Output Frequency | V | 2.5 | 3.0 | 3.0 | 3.0 | 25.0 | 25.0 | 30.0 | 30.0 |
| E1-08 | Mid. Output Frequency Voltage | V | 17.2 | 17.2 | 17.2 | 17.2 | 40.2 | 57.5 | 40.2 | 57.5 |
| E1-09 | Min. Output Frequency | Hz | 1.3 | 1.5 | 1.5 | 1.5 | 1.3 | 1.3 | 1.5 | 1.5 |
| E1-10 | Min. Output Frequency Voltage | V | 10.3 | 10.3 | 10.3 | 10.3 | 9.2 | 10.3 | 9.2 | 10.3 |

For 460V class units, the value is twice that of 230V class units. For 575V class units the value is 2.5 times the 230V value.

Inverter Capacity 0.4 ~ 1.5kW for 200V Class (Continued)

| Parameter No. | Name | Unit | Factory Setting | | | | | | | |
|---------------|-------------------------------|------|-----------------|-------|-------|-------|-------|-------|-------|-------|
| | | | 8 | 9 | A | B | C | D | E | F |
| E1-03 | V/f Pattern Selection | — | 8 | 9 | A | B | C | D | E | F |
| E1-04 | Max. Output Frequency | Hz | 50.0 | 50.0 | 60.0 | 60.0 | 90.0 | 120.0 | 180.0 | 60.0 |
| E1-05 | Max. Voltage | V | 230.0 | 230.0 | 230.0 | 230.0 | 230.0 | 230.0 | 230.0 | 230.0 |
| E1-06 | Max. Voltage Frequency | Hz | 50.0 | 50.0 | 60.0 | 60.0 | 60.0 | 60.0 | 60.0 | 60.0 |
| E1-07 | Mid. Output Frequency | V | 2.5 | 2.5 | 3.0 | 3.0 | 3.0 | 3.0 | 3.0 | 3.0 |
| E1-08 | Mid. Output Frequency Voltage | V | 21.8 | 27.6 | 21.8 | 27.6 | 17.2 | 17.2 | 17.2 | 17.2 |
| E1-09 | Min. Output Frequency | Hz | 1.3 | 1.3 | 1.5 | 1.5 | 1.5 | 1.5 | 1.5 | 1.5 |
| E1-10 | Min. Output Frequency Voltage | V | 12.6 | 14.9 | 12.6 | 17.2 | 10.3 | 10.3 | 10.3 | 10.3 |

For 460V class units, the value is twice that of 230V class units. For 575V class units the value is 2.5 times the 230V value.

V/F Patterns for Inverter Capacity 2.2 ~ 45kW for 200V Class

| Parameter No. | Name | Unit | Factory Setting | | | | | | | |
|---------------|-------------------------------|------|-----------------|-------|-------|-------|-------|-------|-------|-------|
| | | | 0 | 1 | 2 | 3 | 4 | 5 | 6 | 7 |
| E1-03 | V/f Pattern Selection | — | 0 | 1 | 2 | 3 | 4 | 5 | 6 | 7 |
| E1-04 | Max. Output Frequency | Hz | 50.0 | 60.0 | 60.0 | 72.0 | 50.0 | 50.0 | 60.0 | 60.0 |
| E1-05 | Max. Voltage | V | 230.0 | 230.0 | 230.0 | 230.0 | 230.0 | 230.0 | 230.0 | 230.0 |
| E1-06 | Max. Voltage Frequency | Hz | 50.0 | 60.0 | 50.0 | 60.0 | 50.0 | 50.0 | 60.0 | 60.0 |
| E1-07 | Mid. Output Frequency | V | 2.5 | 3.0 | 3.0 | 3.0 | 25.0 | 25.0 | 30.0 | 30.0 |
| E1-08 | Mid. Output Frequency Voltage | V | 16.1 | 16.1 | 16.1 | 16.1 | 40.2 | 57.5 | 40.2 | 57.5 |
| E1-09 | Min. Output Frequency | Hz | 1.3 | 1.5 | 1.5 | 1.5 | 1.3 | 1.3 | 1.5 | 1.5 |
| E1-10 | Min. Output Frequency Voltage | V | 8.0 | 8.0 | 8.0 | 8.0 | 6.9 | 8.0 | 6.9 | 8.0 |

For 460V class units, the value is twice that of 230V class units. For 575V class units the value is 2.5 times the 230V value.

V/F Patterns for Inverter Capacity 2.2 ~ 45kW for 200V Class (Continued)

| Parameter No. | Name | Unit | Factory Setting | | | | | | | |
|---------------|-------------------------------|------|-----------------|-------|-------|-------|-------|-------|-------|-------|
| | | | 8 | 9 | A | B | C | D | E | F |
| E1-03 | V/f Pattern Selection | — | 8 | 9 | A | B | C | D | E | F |
| E1-04 | Max. Output Frequency | Hz | 50.0 | 50.0 | 60.0 | 60.0 | 90.0 | 120.0 | 180.0 | 60.0 |
| E1-05 | Max. Voltage | V | 230.0 | 230.0 | 230.0 | 230.0 | 230.0 | 230.0 | 230.0 | 230.0 |
| E1-06 | Max. Voltage Frequency | Hz | 50.0 | 50.0 | 60.0 | 60.0 | 60.0 | 60.0 | 60.0 | 60.0 |
| E1-07 | Mid. Output Frequency | V | 2.5 | 2.5 | 3.0 | 3.0 | 3.0 | 3.0 | 3.0 | 3.0 |
| E1-08 | Mid. Output Frequency Voltage | V | 20.7 | 26.4 | 20.7 | 26.4 | 16.1 | 16.1 | 16.1 | 16.1 |
| E1-09 | Min. Output Frequency | Hz | 1.3 | 1.3 | 1.5 | 1.5 | 1.5 | 1.5 | 1.5 | 1.5 |
| E1-10 | Min. Output Frequency Voltage | V | 10.3 | 12.6 | 10.3 | 14.9 | 8.0 | 8.0 | 8.0 | 8.0 |

For 460V class units, the value is twice that of 230V class units. For 575V class units the value is 2.5 times the 230V value.

V/F Patterns for Inverter Capacity 55 ~ 300kW for 200V Class

| Parameter No. | Name | Unit | Factory Setting | | | | | | | |
|---------------|-------------------------------|------|-----------------|----------|----------|----------|----------|----------|----------|----------|
| | | | 0 | 1 | 2 | 3 | 4 | 5 | 6 | 7 |
| E1-03 | V/f Pattern Selection | – | 0 | 1 | 2 | 3 | 4 | 5 | 6 | 7 |
| E1-04 | Max. Output Frequency | Hz | 50.0<21> | 60.0 | 60.0 | 72.0<21> | 50.0<21> | 50.0<21> | 60.0 | 60.0 |
| E1-05 | Max. Voltage | V | 230.0 | 230.0 | 230.0 | 230.0 | 230.0 | 230.0 | 230.0 | 230.0 |
| E1-06 | Max. Voltage Frequency | Hz | 50.0<21> | 60.0 | 50.0<21> | 60.0 | 50.0<21> | 50.0<21> | 60.0 | 60.0 |
| E1-07 | Mid. Output Frequency | V | 2.5<21> | 3.0 | 3.0 | 3.0 | 25.0<21> | 25.0<21> | 30.0 | 30.0 |
| E1-08 | Mid. Output Frequency Voltage | V | 13.8<21> | 13.8<21> | 13.8<21> | 13.8<21> | 40.2<21> | 57.5<21> | 40.2<21> | 57.5<21> |
| E1-09 | Min. Output Frequency | Hz | 1.3<21> | 1.5 | 1.5 | 1.5 | 1.3<21> | 1.3<21> | 1.5 | 1.5 |
| E1-10 | Min. Output Frequency Voltage | V | 6.9 | 6.9 | 6.9 | 6.9 | 5.7<21> | 6.9 | 5.7<21> | 6.9 |

For 460V class units, the value is twice that of 230V class units. For 575V class units the value is 2.5 times the 230V value.

V/F Patterns for Inverter Capacity 55 ~ 300kW for 200V Class (Continued)

| Parameter No. | Name | Unit | Factory Setting | | | | | | | |
|---------------|-------------------------------|------|-----------------|----------|----------|----------|----------|-----------|-----------|----------|
| | | | 8 | 9 | A | B | C | D | E | F |
| E1-03 | V/f Pattern Selection | – | 8 | 9 | A | B | C | D | E | F |
| E1-04 | Max. Output Frequency | Hz | 50.0<21> | 50.0<21> | 60.0 | 60.0 | 90.0<21> | 120.0<21> | 180.0<21> | 60.0 |
| E1-05 | Max. Voltage | V | 230.0 | 230.0 | 230.0 | 230.0 | 230.0 | 230.0 | 230.0 | 230.0 |
| E1-06 | Max. Voltage Frequency | Hz | 50.0<21> | 50.0<21> | 60.0 | 60.0 | 60.0 | 60.0 | 60.0 | 60.0 |
| E1-07 | Mid. Output Frequency | V | 2.5<21> | 2.5<21> | 3.0 | 3.0 | 3.0 | 3.0 | 3.0 | 3.0 |
| E1-08 | Mid. Output Frequency Voltage | V | 17.2<21> | 23.0<21> | 17.2<21> | 23.0<21> | 13.8<21> | 13.8<21> | 13.8<21> | 13.8<21> |
| E1-09 | Min. Output Frequency | Hz | 1.3<21> | 1.3<21> | 1.5 | 1.5 | 1.5 | 1.5 | 1.5 | 1.5 |
| E1-10 | Min. Output Frequency Voltage | V | 8.0<21> | 10.3<21> | 8.0<21> | 12.6<21> | 6.9 | 6.9 | 6.9 | 6.9 |

For 460V class units, the value is twice that of 230V class units. For 575V class units the value is 2.5 times the 230V value.

E2 Motor Set-up

*E2-01 Motor Rated Current
FLA*

Motor Rated

| | | | |
|---|---|---|---|
| Q | Q | Q | Q |
|---|---|---|---|

Sets the motor rated current in units of 0.01A for inverter models 27P5, 47P5 and smaller; 0.1A for models G5U2011, G5U4011 and larger. The default setting varies depending on the inverter model setting (O2-04).

E2-02 Motor Rated Slip Frequency

Motor Rated Slip

| | | | |
|---|---|---|---|
| A | A | Q | Q |
|---|---|---|---|

Setting range: 0.00 to 20.00Hz

Sets the motor rated slip frequency in units of 0.01Hz. The default setting varies depending on the inverter model setting (O2-04). Use the following equation to calculate the motor rated slip frequency:

$$f_s = f - \frac{N \cdot P}{120}$$

where:

- f_s : slip frequency (Hz)
- f : rated frequency (Hz)
- N : rated motor speed (rpm)
- P : number of motor poles

E2-03 Motor No-Load Current

No-Load Current

| | | | |
|---|---|---|---|
| A | A | Q | Q |
|---|---|---|---|

Sets the motor no-load current in units of 0.01A for inverter models 27P5, 47P5 and smaller; 0.1A for models G5U2011, G5U4011 and larger. The default setting varies depending on the inverter model setting (O2-04).

E2-04 Number of Motor Poles

Number of Poles

| | | | |
|----|---|----|---|
| -- | Q | -- | Q |
|----|---|----|---|

Setting Range: 2 to 48 poles
Factory Default: 4 poles

Sets the number of motor poles.

E2-05 Motor Terminal Resistance

Term Resistance

| | | | |
|---|---|---|---|
| A | A | A | A |
|---|---|---|---|

Sets the motor phase-to-phase resistance value in units of 0.01W.

$$\text{Phase-to-Phase Resistance at Insulation Class Temperature} \times \frac{273 + (25^\circ\text{C} + \text{insulation class temperature}) / 2}{273 + \text{insulation class temperature}}$$

The default setting varies depending on the inverter model setting (O2-04).

*E2-06 Leakage Inductance**Leak Inductance*

| | | | |
|----|----|---|---|
| -- | -- | A | A |
|----|----|---|---|

Sets the motor leakage inductance in units of 0.1%. The default setting varies depending on the inverter model setting (O2-04).

*E2-07 Core-Saturation Compensation Coefficient 1**Saturation Comp1*

| | | | |
|----|----|---|---|
| -- | -- | A | A |
|----|----|---|---|

Setting Range: 0.00 to 1.00

Factory Default: 0.5

Sets the motor iron core saturation coefficient at 50% of the magnetic flux. This parameter is set automatically during auto-tuning, so it does not need to be changed.

*E2-08 Core-Saturation Compensation Coefficient 2**Saturation Comp2*

| | | | |
|----|----|---|---|
| -- | -- | A | A |
|----|----|---|---|

Setting Range: 0.00 to 1.00

Factory Default: 0.75

Sets the motor iron core saturation coefficient at 75% of the magnetic flux. This parameter is set automatically during auto-tuning, so it does not need to be changed.

*E2-09 Motor Mechanical Loss**Mechanical Loss*

| | | | |
|----|----|----|---|
| -- | -- | -- | A |
|----|----|----|---|

Setting Range: 0.0 to 10.0%

Factory Default: 0.0%

Sets the motor mechanical loss as a percentage of motor rated output power, in units of 0.1%.

*E2-10 Motor Iron Loss Torque Compensation <1110>**Tcomp Iron Loss*

| | | | |
|---|---|----|----|
| A | A | -- | -- |
|---|---|----|----|

Setting Range: 0 to 65535

Factory Default: 14 (Factory default depends on inverter capacity.)

This parameter sets the motor iron loss of the torque compensation.

E3 Motor 2 Set-up

E3-01 Motor 2 Control Method Selection

Control Method

| | | | |
|---|---|---|---|
| A | A | A | A |
|---|---|---|---|

The FST-800 inverter has the capability to control 2 motors independently. A second motor may be selected using a multi-function contact input.

Select the control method best suited for your application for Motor 2.

| Setting | Description |
|---------|---|
| 0 | V/f Control - For general-purpose and multiple motor applications. |
| 1 | V/f with PG Feedback - For general-purpose applications requiring closed loop speed control. |
| 2 | Open Loop Vector (<i>factory default</i>) - For applications requiring precise speed control, quick response and higher torque at low speeds (150% torque below 1Hz). |
| 3 | Flux Vector - For applications requiring very precise speed and torque control at a wide speed range including 0 speed. Uses encoder feedback. |

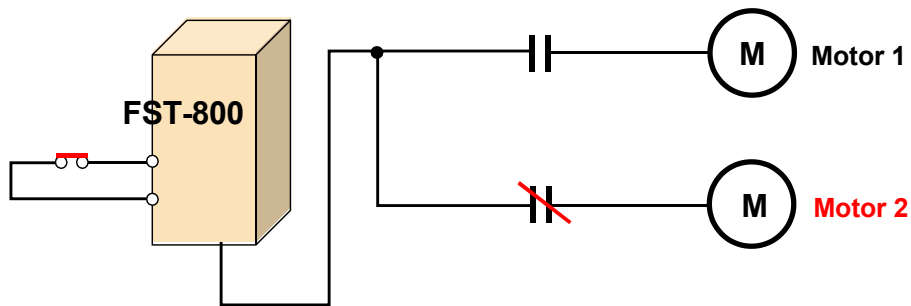

The following is a list of parameters that become effective when motor 2 is selected.

| Function E3 Control Method 2 | | Function E4 V/F Pattern 2 | | Function E5 Motor Setup 2 | |
|---------------------------------|------------------|------------------------------|----------------|------------------------------|------------------|
| E3-01 | Control Method 2 | E4-01 | Max Frequency | E5-01 | Motor Rated FLA |
| | | E4-02 | Max Voltage | E5-02 | Motor Rated Slip |
| | | E4-03 | Base Frequency | E5-03 | No-Load Current |
| | | E4-04 | Mid Frequency | E5-05 | Term Resistance |
| | | E4-05 | Mid Voltage | E5-06 | Leak Inductance |
| | | E4-06 | Min Frequency | | |
| | | E4-07 | Min Voltage | | |

The inverter must be stopped to switch motors.

The motor 2 parameters are identical to the motor 1 parameters. Refer to E1-03 through E1-10.

| | | | | | | | |
|--------------|--|------------------------|---|---|---|---|---|
| <i>E4-01</i> | <i>Motor 2 Maximum Frequency</i> | <i>Max Frequency</i> | <table border="1"><tr><td>A</td><td>A</td><td>A</td><td>A</td></tr></table> | A | A | A | A |
| A | A | A | A | | | | |
| <i>E4-02</i> | <i>Motor 2 Maximum Voltage</i> | <i>Max Voltage</i> | <table border="1"><tr><td>A</td><td>A</td><td>A</td><td>A</td></tr></table> | A | A | A | A |
| A | A | A | A | | | | |
| <i>E4-03</i> | <i>Motor 2 Base Frequency</i> | <i>Base Frequency</i> | <table border="1"><tr><td>A</td><td>A</td><td>A</td><td>A</td></tr></table> | A | A | A | A |
| A | A | A | A | | | | |
| <i>E4-04</i> | <i>Motor 2 Middle Output Frequency A</i> | <i>Mid Frequency A</i> | <table border="1"><tr><td>A</td><td>A</td><td>A</td><td></td></tr></table> | A | A | A | |
| A | A | A | | | | | |
| <i>E4-05</i> | <i>Motor 2 Middle Output Voltage A</i> | <i>Mid Voltage A</i> | <table border="1"><tr><td>A</td><td>A</td><td>A</td><td></td></tr></table> | A | A | A | |
| A | A | A | | | | | |
| <i>E4-06</i> | <i>Motor 2 Minimum Output Frequency</i> | <i>Min Frequency</i> | <table border="1"><tr><td>A</td><td>A</td><td>A</td><td>A</td></tr></table> | A | A | A | A |
| A | A | A | A | | | | |
| <i>E4-07</i> | <i>Motor 2 Minimum Output Voltage</i> | <i>Min Voltage</i> | <table border="1"><tr><td>A</td><td>A</td><td>A</td><td></td></tr></table> | A | A | A | |
| A | A | A | | | | | |

E5 Motor 2 Set-up

| | | | | | | | |
|--------------|------------------------------|------------------------|---|---|---|---|---|
| <i>E5-01</i> | <i>Motor 2 Rated Current</i> | <i>Motor Rated FLA</i> | <table border="1"><tr><td>A</td><td>A</td><td>A</td><td>A</td></tr></table> | A | A | A | A |
| A | A | A | A | | | | |

Sets the motor rated current in units of 0.01A for inverter models 27P5, 47P5 and smaller; 0.1A for models G5U2011, G5U4011 and larger. The default setting varies depending on the inverter model setting (O2-04).

| | | | | | | | |
|--------------|-------------------------------------|-------------------------|---|---|---|---|---|
| <i>E5-02</i> | <i>Motor 2 Rated Slip Frequency</i> | <i>Motor Rated Slip</i> | <table border="1"><tr><td>A</td><td>A</td><td>A</td><td>A</td></tr></table> | A | A | A | A |
| A | A | A | A | | | | |
| | Setting range: | 0.00 to 20.00Hz | | | | | |

Sets the motor rated slip frequency in units of 0.01Hz. The default setting varies depending on the inverter model setting (O2-04). Use the following equation to calculate the motor rated slip frequency:

$$f_s = f - \frac{N \cdot P}{120}$$

- where:
- f_s : slip frequency (Hz)
 - f : rated frequency (Hz)
 - N : rated motor speed (rpm)
 - P : number of motor poles

| | | | | | | | |
|--------------|--------------------------------|------------------------|---|---|---|---|---|
| <i>E5-03</i> | <i>Motor 2 No-Load Current</i> | <i>No-Load Current</i> | <table border="1"><tr><td>A</td><td>A</td><td>A</td><td>A</td></tr></table> | A | A | A | A |
| A | A | A | A | | | | |

Sets the motor no-load current in units of 0.01A for inverter models 27P5, 47P5 and smaller; 0.1A for models G5U2011, G5U4011 and larger. The default setting varies depending on the inverter model setting (O2-04).

| | | | | | | | |
|--------------|--------------------------------------|------------------------|---|----|---|----|---|
| <i>E5-04</i> | <i>Motor 2 Number of Motor Poles</i> | <i>Number of Poles</i> | <table border="1"><tr><td>--</td><td>A</td><td>--</td><td>A</td></tr></table> | -- | A | -- | A |
| -- | A | -- | A | | | | |

Setting Range: 2 to 48 poles
 Factory Default: 4 poles

Sets the number of motor poles for motor 2.

E5-05 Motor 2 Terminal Resistance

Term Resistance

| | | | |
|---|---|---|---|
| A | A | A | A |
|---|---|---|---|

Sets the motor phase-to-phase resistance value in units of 0.01W.

$$\text{Phase-to-Phase Resistance at Insulation Class Temperature} \times \frac{273 + (25^\circ\text{C} + \text{insulation class temperature}) / 2}{273 + \text{insulation class temperature}}$$

The default setting varies depending on the inverter model setting (O2-04).

E5-06 Motor 2 Leakage Inductance

Leak Inductance

| | | | |
|---|----|---|---|
| A | -- | A | A |
|---|----|---|---|

Sets the motor leakage inductance in units of 0.1%. The default setting varies depending on the inverter model setting (O2-04).

F Option Parameters

F1 PG Option Set-up

These parameters can be accessed during operation using a pulse generator (PG) for speed feedback.

When access level is BASIC (A1-03), the parameter is not displayed unless the option card is connected.

F1-01 PG Pulses per Revolution

PG Pulses/Rev

| | | | |
|----|---|----|---|
| -- | Q | -- | Q |
|----|---|----|---|

Setting Range: 0 to 60000
 Factory Default: 1024

Sets the number of PG pulses per motor revolution (pulses/rev).

F1-02 PG Disconnection Detection Stopping Method PG Fdbk Loss Sel

| | | | |
|----|---|----|---|
| -- | B | -- | B |
|----|---|----|---|

Selects the stopping method when a disconnected PG is detected.

| Setting | Description |
|---------|--|
| 0 | Ramp to stop - according to C1-02 |
| 1 | Coast to stop (<i>factory default</i>) |
| 2 | Fast-stop according to C1-09 |
| 3 | Alarm flashes, operation continues (this setting is disabled during flux vector control) |

F1-03 Overspeed Detection Stopping Method

PG Overspeed Sel

| | | | |
|----|---|----|---|
| -- | B | -- | B |
|----|---|----|---|

Selects the stopping method when an overspeed condition is detected.

| Setting | Description |
|---------|--|
| 0 | Ramp to stop - according to C1-02 |
| 1 | Coast to stop (<i>factory default</i>) |
| 2 | Fast-stop according to C1-09 |
| 3 | Alarm flashes, operation continues (this setting is disabled during flux vector control) |

F1-04 PG Deviation Detection Stopping Method

PG Deviation Sel

| | | | |
|----|---|----|---|
| -- | B | -- | B |
|----|---|----|---|

Selects the stopping method when excessive speed deviation is detected.

| Setting | Description |
|---------|---|
| 0 | Ramp to stop - according to C1-02 |
| 1 | Coast to stop |
| 2 | Fast-stop according to C1-09 |
| 3 | Alarm flashes, operation continues (<i>factory default</i>) |

F1-05 PG Rotation Selection

PG Rotation Sel

| | | | |
|----|---|----|---|
| -- | B | -- | B |
|----|---|----|---|

Sets the relationship between the motor rotation direction and PG polarity.

| Setting | Description |
|---------|---|
| 0 | Motor FWD direction is counterclockwise (<i>factory default</i>). |
| 1 | Motor FWD direction is clockwise. |

The motor rotation direction applies when viewing the motor shaft from the load side.

F1-06 PG Division Rate (pulse output)

PG Output Ratio

| | | | |
|----|---|----|---|
| -- | B | -- | B |
|----|---|----|---|

Setting Range: 1 to 132

Factory Default: 1

Sets the division ratio for monitoring the PG pulse signals.

Division Ratio = $\frac{n+1}{m}$ Data →

Setting Example:
 When F1-06 is set to "132". then the division ratio = $\frac{1+1}{32} = \frac{2}{16}$

This parameter is effective only when the printed circuit board PG-B2 is used

F1-07 Integral Value During Accel/Decel PG Ramp PI/I Sel

| | | | |
|----|---|----|----|
| -- | B | -- | -- |
|----|---|----|----|

Selects whether speed control (ASR) integral operation is activated during acceleration/deceleration.

| Setting | Description |
|---------|---|
| 0 | Integral operation disabled (factory default) |
| 1 | Integral operation enabled |

F1-08 Overspeed Detection Level PG Overspd Level

| | | | |
|----|---|----|---|
| -- | A | -- | A |
|----|---|----|---|

Setting Range: 0 to 120%
 Factory Default: 115%

Sets the motor overspeed detection level as a percentage of maximum output frequency (E1-04).

F1-09 Overspeed Detection Time PG Overspd Time

| | | | |
|----|---|----|---|
| -- | A | -- | A |
|----|---|----|---|

Setting Range: 0.0 to 2.0s
 Factory Default: 0.0s

Sets the elapsed time from when an overspeed condition is detected to when a fault occurs.

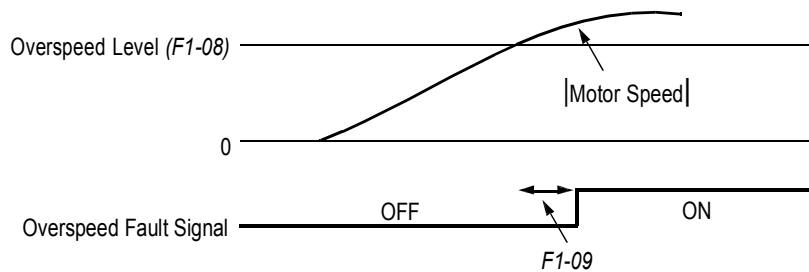

Figure 29 Overspeed Detection Timing Diagram

A fault signal is output to stop operation after the absolute value of the motor speed exceeds the set value of F1-08 and after the time set to F1-09 elapses. The stopping method is set by F1-03. When parameter A1-02=1 [V/f w/PG] the factory setting will be 1.0. When parameter A1-02=3 [Flux Vector] the factory setting will be 0.0.

F1-10 PG Deviation Detection Level

PG Deviate Level

| | | | |
|---|---|----|---|
| - | A | -- | A |
|---|---|----|---|

Setting Range: 0 to 50%

Factory Default: 115%

Sets the excessive speed deviation detection level as a percentage of maximum output frequency (*E1-04*).

F1-11 PG Deviation Detection Time

PG Deviate Time

| | | | |
|---|---|----|---|
| - | A | -- | A |
|---|---|----|---|

Setting Range: 0.0 to 2.0s

Factory Default: 0.0s

Sets the elapsed time from when excessive speed deviation is detected to when a fault occurs.

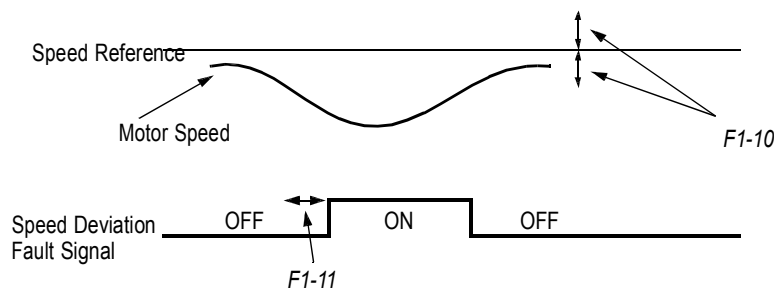

Figure 30 Overspeed Detection Timing Diagram

A fault signal is output to stop operation after the deviation between speed reference and the motor speed exceeds the set value of *F1-10* and after the time set to *F1-11* elapses. The stopping method is set by *F1-04*. Also, detection is not activated while accelerating/decelerating or during torque control.

F1-12 Number of Teeth Gear 1

PG # Gear Teeth1

F1-13 Number of Teeth Gear 2

PG # Gear Teeth2

| | | | |
|--|---|--|--|
| | A | | |
| | A | | |

Setting Range: 0 to 1000

Factory Default: 0

Sets the number of teeth for each gear when gears are installed between the motor and the PG. When the number of gear teeth is set, the motor revolutions per minute (rpm) are calculated as shown below.

$$\text{No. of Motor RPM's} = \frac{\text{No. of PG Output Pulses} \times 60}{\text{PG Pulses/Revolution (F1-01)}} \times \frac{\text{No. of Teeth Gear 2 (F1-13)}}{\text{No. of Teeth Gear 1 (F1-12)}}$$

This function is disabled when either *F1-12* or *F1-13* = "0".

F1-14 PGO Detection Time

PGO Detect Time

| | | | |
|---|---|----|---|
| - | A | -- | A |
|---|---|----|---|

Setting Range: 0.0 to 10 seconds
 Factory Default: 2 seconds

Parameter F1-14 sets the time from when the pulse generator (PG) signal is missing to when the fault signal is displayed.

The stopping method when a “PGO” fault is detected is selected by parameter F1-02.

If a speed reference is commanded, but the motor is physically locked, a “PGO” fault will occur even though the PG is not disconnected from the inverter.

F2 AI-14B Set-up

F2-01 Bipolar or Unipolar Input Selection

AI-14 Input Sel

| | | | |
|---|---|---|---|
| A | A | A | A |
|---|---|---|---|

Sets CH1 to CH3 input functions when AI-14B option is connected.

| Setting | Function | CH1 (TC1 to TC4) | CH2 (TC2 to TC4) | CH3 (TC3 to TC4) |
|---------|---|--|------------------------------------|------------------------------------|
| 0 | 3-channel individual input (<i>factory default</i>) | Substitute for terminals 13 and 17 | Substitute for terminals 14 and 17 | Substitute for terminals 16 and 17 |
| 1 | 3-channel additional input | Sum of CH1 to CH3 input values is used as the frequency reference value. | | |

When the 3CH individual input is used, parameter *B1-01* is automatically set to “I” (frequency reference from control circuit terminal). The option/inverter reference selection, which is selected by a multi-function contact input (*H1-__ = “2”*), is disabled when using the AI-14B option.

F3 DI-08/DI-16H Set-up

F3-01 Digital Input Option

DI Input

| | | | |
|---|---|---|---|
| A | A | A | A |
|---|---|---|---|

Selects the setting mode of the frequency reference input from the DI-08 and DI-16H options.

| Setting | Frequency Reference Setting Mode |
|---------|---|
| 0 | BCD 1% unit (<i>factory default</i>) |
| 1 | BCD 0.1% unit |
| 2 | BCD 0.01% unit |
| 3 | BCD 1Hz unit |
| 4 | BCD 0.1Hz unit |
| 5 | BCD 0.01Hz unit |
| 6 | Binary DI-08: 255/100% DI-16H, 12-bit selection: 4096/100% DI- 16H, 16-bit selection: 30000/100% |
| 7 | Binary, set value is displayed in decimal notation. |

F4 AO-08/AO-12 Set-up

F4-01 Analog Output Channel 1 Selection

AO CHI Select

| | | | |
|---|---|---|---|
| A | A | A | A |
|---|---|---|---|

Selects the analog output monitors for channel 1 of the AO-08 and AO-12 options.

Analog Output Channel 1 Selection

| F4-01 Setting | Function | Description |
|---------------|---|---|
| 1 | Frequency reference | Monitors the frequency reference value. 10V= Max frequency (0-+/-10V possible) |
| 2 | Output frequency (<i>factory default</i>) | Monitors the output frequency. 10V= Max frequency (0-+/-10V possible) |
| 3 | Inverter output current | Monitors the output current. 10V=Rated current (0 to +10V output) |
| 5 | Motor speed | Monitors the motor speed. 10V= Max frequency (0 to +/- 10 V possible) |
| 6 | Output voltage | Monitors the inverters internal output voltage reference value. 10V=200,400 or 575 VAC |
| 7 | DC bus voltage | Monitors the DC voltage of the inverters internal main circuit. 10V=400 or 800 VDC (0 to +10V output) |
| 8 | Output power | Monitors the output power, this is an internally detected value. 10V=Max motor capacity. (0 to +/-10 V possible) |
| 9 | Torque reference (internal) | Monitors the internal torque reference value when vector control is used. 10 V=Rated torque. (0 to +/-10V possible) |
| 10-14 | Not Used | -- |
| 15 | Terminal 13 input voltage level | Monitors the input voltage of the frequency reference (voltage). An input of 10 V corresponds to 100%. 10 V=100% (10 V) 0 to +/-10 V possible. |
| 16 | Terminal 14 input voltage or current level | Monitors the input current of the frequency reference. (current) An input of 20 mA corresponds to 100%. 20 mA=100% (20 mA) 0 to + 10 V output. |
| 17 | Terminal 16 input voltage level | Monitors the input voltage of the multi-function analog input. An input of 10 V corresponds to 100%. 10 V= 100% (10 V). (0 to +/-10 V possible) |
| 18 | Motor secondary current (Iq) | Monitors the calculated value of the motors secondary current. (Iq) The motors rated secondary current corresponds to 100%. 10 V=Rated secondary current. (0 to + 10 V output) |
| 19 | Motor excitation current (Id) | Monitors the calculated value of the motors excitation current. (Id) The motors rated excitation current corresponds to 100%. 10 V=Rated excitation current. (0 to + 10 V output). |
| 20 | SFS output frequency | Monitors the output frequency after a soft start. This is the frequency without the correction from compensation functions such as slip compensation. 10 V=Max. frequency (0 to +/- 10 V possible) |
| 21 | ASR input | Monitors the input to the speed control loop. The max. frequency corresponds to 100%. 10 V=Max. frequency (0 to +/- 10 V possible) |
| 22 | ASR output | Monitors the output from the speed control loop. Analog monitor becomes 10 V/ max. output frequency with V/F control. In vector control the analog monitor becomes 10V= motor rated excitation current. (0 to +/-10V possible.) |
| 23 | Speed deviation | Monitors the speed deviation within the speed control loop. The max. frequency corresponds to 100%. 10 V=Max. frequency (0 to +/-10 V possible.) |
| 24 | PID feedback | Monitors the feedback value when the PID control is utilized. The input for the max. frequency corresponds to 100%. 10 V= Max frequency. (0 to +/-10 V possible.) |
| 25 | Not Used | -- |
| 26 | Voltage reference (Vq output) | Monitors the inverters internal voltage reference value for the motors secondary current control. 10 V= 200,400 or 575 VAC (0 to +/- 10 V possible.) |
| 27 | Voltage reference (Vd output) | Monitors the inverters internal voltage reference value for the motors excitation current control. 10 V= 200,400 or 575 VAC (0 to +/- 10 V possible.) |
| 28-30 | Not Used | -- |
| 31 | Not Used | -- |

| F4-01 Setting | Function | Description |
|---------------|---------------------------|--|
| 32 | ACR(q) Output | Monitors current control output value for the motors secondary current. 10 V= 100%. |
| 33 | ACR(d) Output | Monitors current control output value for the motors excitation current. 10 V= 100%. |
| 34-35 | Not Used | -- |
| 36 | PID Input Monitor | Monitors the input to the PID circuit. This is the PID reference + the PID reference bias - the PID feedback. 10 V= Max frequency. |
| 37 | PID Output Monitor | Monitors the output of the PID circuit. 10 V= Max frequency. |
| 38 | PID Setpoint or Reference | Monitors the PID setpoint. This is the PID setpoint + the PID setpoint bias. 10 V= Max frequency. |

F4-02 Analog Output Channel 1 Gain

AO CH1 Gain

| | | | |
|---|---|---|---|
| A | A | A | A |
|---|---|---|---|

Setting Range: 0.00 to 2.50
 Factory Default: 1.00

Sets the channel 1 output gain for the analog output monitors. To obtain the output level, multiply the monitor output level by the gain value set in *F4-02*.

F4-03 Analog Output Channel 2 Selection

AO CH2 Select

| | | | |
|---|---|---|---|
| A | A | A | A |
|---|---|---|---|

Setting Range: Same as *F4-01*
 Factory Default: Inverter output current (setting = "3")

Selects the analog output monitors for channel 2 of the AO-08 and AO-12 options.

F4-04 Analog Output Channel 2 Gain

AO CH2 Gain

| | | | |
|---|---|---|---|
| A | A | A | A |
|---|---|---|---|

Setting Range: 0.00 to 2.50
 Factory Default: 0.50

Sets the channel 2 output gain for the analog output monitors. To obtain the output level, multiply the monitor output level by the gain value set in *F4-04*.

F4-05 Analog Output Channel 1 Bias

AO CH1 Bias

| | | | |
|---|---|---|---|
| A | A | A | A |
|---|---|---|---|

Setting Range: -10.0 to + 10.0
 Factory Default: 0.0

Sets the channel 1 output bias for the analog output monitors. This is for the AO-08 and AO-12 option cards.

F4-06 Analog Output Channel 2 Bias

AO CH2 Bias

| | | | |
|---|---|---|---|
| A | A | A | A |
|---|---|---|---|

Setting Range: -10.0 to + 10.0
 Factory Default: 0.0

Sets the channel 2 output bias for the analog output monitors. This is for the AO-08 and AO-12 option cards.

F5 DO-02 Set-up

The DO-02C option card has 2 form C type dry contacts. Each of the dry contacts can be individually set by F5-01 and F5-02.

The DO-02C option card connects to the control board at 3CN.

The table is a list of items that can be selected.

F5-01 DO-02C Digital Output Channel 1 Selection DO-02 CH1 Select

| | | | |
|---|---|---|---|
| A | A | A | A |
|---|---|---|---|

Selects the multi-function output selections for channel 1 of the DO-02C option.

For detailed information on these settings, refer to section **H2, Digital Outputs**, on page 88.

| Setting | Descriptio | Setting | Descriptio |
|---------|---|---------|---------------------------|
| 0 | During run 1 (<i>factory default</i>) | 13 | Fref/Fout agree 2 |
| 1 | Zero speed | 14 | Fref/set agree 2 |
| 2 | Fref/Fout agree 1 | 15 | Frequency detection 3 |
| 3 | Fref/set agree 1 | 16 | Frequency detection 4 |
| 4 | Frequency detection 1 | 17 | Torque detection 1 (N.C.) |
| 5 | Frequency detection 2 | 18 | Torque detection 2 (N.O.) |
| 6 | Inverter ready | 19 | Torque detection 2 (N.C.) |
| 7 | DC bus undervoltage | 1A | Reverse direction |
| 8 | Baseblock 1 | 1B | Baseblock 2 |
| 9 | Option frequency reference | 1C | Motor 2 selected |
| A | Remote operation | 1D | Regenerating |
| B | Torque detection 1 (N.O.) | 1E | Restart enabled |
| C | Loss of reference | 1F | Overload (OL1) |
| D | DB overheat | 20 | OH pre-alarm |
| E | Fault | 30 | Current/torque limit |
| F | Not used | 31 | Speed limit |
| 10 | Minor fault | 33 | Zero servo end |
| 11 | Reset command active | 37 | During run 2 |
| 12 | Timer output | - | -- |

F5-02 DO-02C Digital Output Channel 2 Selection Select

DO-02 CH2

| | | | |
|---|---|---|---|
| A | A | A | A |
|---|---|---|---|

Setting Range: Same as *F5-01*

Factory Default: Zero speed (setting = "1")

Selects the multi-function output selections for channel 2 of the DO-02C option.

F6 DO-08 Set-up

F6-01 DO-08 Digital Output Selection

DO-08 Selection

| | | | |
|---|---|---|---|
| A | A | A | A |
|---|---|---|---|

Selects the multi-function output selections for the DO-08 option.

| Setting | Terminal No. | Descriptio |
|--|--------------|-----------------------------|
| 0 8-channel individual (factory default) | TD5/TD11 | Overcurrent (SC, OC, GF) |
| | TD6/TD11 | Overvoltage (OV) |
| | TD7/TD11 | Inverter overload (OL2) |
| | TD8/TD11 | Fuse blown (FU) |
| | TD9/TD11 | Not used |
| | TD10/TD11 | Inverter overheat (OH) |
| | TD1/TD2 | During zero-speed detection |
| | TD3/TD4 | During speed agree |
| 1 binary output | TD5/TD11 | Binary output * |
| | TD6/TD11 | |
| | TD7/TD11 | |
| | TD8/TD11 | |
| | TD9/TD11 | During zero-speed detection |
| | TD10/TD11 | During speed agree |
| | TD1/TD2 | During run |
| | TD3/TD4 | Minor fault |

* When F6-01 is set to binary output (setting = "1"), use the table below to read the DO-08 output.

| TD8/TD1 1 (bit | TD7/TD1 1 (bit 2) | TD6/TD1 1 (bit 1) | TD5/TD1 1 (bit 0) | Description |
|-------------------|----------------------|----------------------|----------------------|---------------------------------|
| 0 | 0 | 0 | 0 | No fault |
| 0 | 0 | 0 | 1 | Overcurrent (SC, OC, GF) |
| 0 | 0 | 1 | 0 | Overvoltage (OV) |
| 0 | 0 | 1 | 1 | Inverter overload (OL2) |
| 0 | 1 | 0 | 0 | Inverter overheat (OH) |
| 0 | 1 | 0 | 1 | Overspeed (OS) |
| 0 | 1 | 1 | 0 | Fuse blown (FU) |
| 0 | 1 | 1 | 1 | Not used |
| 1 | 0 | 0 | 0 | External fault (EF3 ~ EF8) |
| 1 | 0 | 0 | 1 | Controller fault |
| 1 | 0 | 1 | 0 | Motor overload (OL1) |
| 1 | 0 | 1 | 1 | Not used |
| 1 | 1 | 0 | 0 | Power loss (UV1, UV2, UV3) |
| 1 | 1 | 0 | 1 | Excessive speed deviation (DEV) |
| 1 | 1 | 1 | 0 | PG disconnection (PGO) |
| 1 | 1 | 1 | 1 | Not used |

Note: When the terminal is open, the bit setting is "0"; when the terminal is closed, the bit setting is "1".

F7 PO-36F Set-up

The PO-36F option card outputs pulse signals that correspond to the inverter output frequency. These signals are used in master/slave configurations where speed matching is needed.

F7-01 PO-36F Pulse Monitor Output Selection PO-36F Selection

| | | | |
|---|---|---|---|
| A | A | A | A |
|---|---|---|---|

Sets the number of pulse signals to be output from the PO-36F option.

| Setting | Number of Output Pulses |
|---------|--|
| 0 | Inverter output frequency × 1 |
| 1 | Inverter output frequency × 6 (<i>factory default</i>) |
| 2 | Inverter output frequency × 10 |
| 3 | Inverter output frequency × 12 |
| 4 | Inverter output frequency × 36 |

F8 Function F8 SI-F/G Set-up

The setting of parameter F8-01 selects the stopping method when an E-15 fault is detected.

F8-01 (E-15) Detection Stopping Method E-15 Det Sel

| | | | |
|---|---|---|---|
| A | A | A | A |
|---|---|---|---|

An E-15 fault may occur when using the SI-F or SI-G communication options. The fault will occur after initial communication has been established then the connection is lost. The following fault code will be displayed:

| Setting | Description |
|---------|--|
| 0 | Ramp to stop according to C1-02 set value |
| 1 | <i>Coast to stop.</i> |
| 2 | Ramp to stop according to C1-09 set value. |
| 3 | Alarm flashes, operation continues. |

F9 CP-916 Setup

The CP-916 option card provides PLC and motion type functions. This allows the FST-800 inverter to be a stand alone control system.

The CP-916 option card connects to the control board at 3CN.

When the CP-916 option is installed, the 4CN speed feedback option port is the only option port that is supported.

Specifications

- RS 232C communication port - Used for programming the CP-916G and for communication to other devices such as PLC's or printers.
- High speed (4 Mb/s) peer to peer communication port.
- Available protocol;
MEMOBUS (MODBUS) 19.2 kbps maximum.
Application Download Tool 19.2 kbps maximum.
CP 717 Programming Tool 9.6 kbps.

F9-01 *Option External Fault Selection*

EFO Selection

| | | | |
|---|---|---|---|
| A | A | A | A |
|---|---|---|---|

Parameter F9-01 selects the initial state for an external fault condition when the inverter is configured for serial communication using the CP-916.

| Setting | Description |
|---------|--|
| 0 | When closed, the inverter will trip. (factory default) |
| 1 | When open, the inverter will trip. |

The “EFO” fault code will be displayed.

F9-02 *Option External Fault Detection*

EFO Detection

| | | | |
|---|---|---|---|
| A | A | A | A |
|---|---|---|---|

Parameter F9-02 selects the condition of detection for an external fault when using the CP-916 option.

| Setting | Description |
|---------|--|
| 0 | The fault will always be detected, even when the drive is stopped. (factory default) |
| 1 | The fault will be detected only when the drive is running. |

F9-03 *Option External Fault Action*

EFO Fault Action

| | | | |
|---|---|---|---|
| A | A | A | A |
|---|---|---|---|

The setting of parameter F9-03 selects the stopping method when an EFO fault is detected.

| Setting | Description |
|---------|--|
| 0 | Ramp to stop according to C1-02 set value. |
| 1 | Coast to stop. (factory setting) |
| 2 | Ramp to stop according to C1-09 set value. |
| 3 | Alarm flashes, operation continues. |

F9-04 *Trace Sample Time*

Trace Sample Tim

| | | | |
|---|---|---|---|
| A | A | A | A |
|---|---|---|---|

Setting Range: 0-60000
 Factory Default: 0

Parameter F9-04 sets the trace sample time when using the CP-916B option card.

F9-05 *Torque Reference/Torque Limit Select (CP-916)* *Torq Ref/Lmt Sel*

| | | | |
|----|----|----|---|
| -- | -- | -- | A |
|----|----|----|---|

Parameter F9-05 allows the CP-916 option card to set the torque limits when the inverter is in the speed control mode and the torque reference when operating in the torque control mode

| Setting | Description |
|---------|--|
| 0 | Disabled - Torque reference/torque limits set by G5 program parameters or by analog input. |
| 1 | Enabled - Torque reference/torque limits set by G5 program parameters, analog input, or by the CP-916. (factory default) |

Operation Truth Table for Parameter F9-05

| Set Value | Speed Control (Torque Limit) | Torque Control (Torque Reference) |
|-----------|--|--|
| F9-05 = 0 | Set by parameter or analog input. | Set by analog input terminal 14 or 16. |
| F9-05 = 1 | Set by CP-916 option card, parameter, or analog input. | Set by CP-916 option card. |

Note: The inverter will use the lowest value from the CP-916, L7-01 to L7-04, or the multi-function analog input terminals 14 or 16.

F9-06 *Bus Fault Select*

Bus Fault Sel

| | | | |
|---|---|---|---|
| A | A | A | A |
|---|---|---|---|

The setting of parameter F9-06 selects the stopping method when an BUS fault is detected. A BUS fault may occur when using the SI-B or the CP-916 communication options. The fault will occur after initial communication has been established then the connection is lost. The following fault code will be displayed: "BUS SI-B Com Err".

| Setting | Description |
|---------|---|
| 0 | Ramp to Stop - Ramp to stop according to C1-02 set value. |
| 1 | Coast to stop. |
| 2 | Fast-Stop - Ramp to stop according to C1-09 set value. |
| 3 | Alarm Only - Alarm flashes, operation continues. |

H Control Circuit Terminal Parameters

H1 Digital Inputs

The FST-800 series has six multi-function contact inputs for the set-up of numerous functions, including multi-step speed operation, PID, speed search, speed/torque control selection, and many other. This section includes descriptions of these functions.

| | | |
|--------------|--|-----------------------|
| <i>H1-01</i> | <i>Multi-function Input Terminal 3 Selection</i> | <i>Terminal 3 Sel</i> |
| <i>H1-02</i> | <i>Multi-function Input Terminal 4 Selection</i> | <i>Terminal 4 Sel</i> |
| <i>H1-03</i> | <i>Multi-function Input Terminal 5 Selection</i> | <i>Terminal 5 Sel</i> |
| <i>H1-04</i> | <i>Multi-function Input Terminal 6 Selection</i> | <i>Terminal 6 Sel</i> |
| <i>H1-05</i> | <i>Multi-function Input Terminal 7 Selection</i> | <i>Terminal 7 Sel</i> |
| <i>H1-06</i> | <i>Multi-function Input Terminal 8 Selection</i> | <i>Terminal 8 Sel</i> |

| | | | |
|---|---|---|---|
| B | B | B | B |
| B | B | B | B |
| B | B | B | B |
| B | B | B | B |
| B | B | B | B |
| B | B | B | B |

The following table lists the function selections for the multi-function contact inputs (terminals 4 to 8), and indicates the control modes during which each function can be enabled.

| H1-01 to 6 Setting | Function | Control Method (A1-02) | | | | Reference Page |
|--------------------------|---|------------------------|-----------|---------------------|-------------|-------------------|
| | | V/f | V/f w/ PG | Open Loop Vector | Flux Vector | |
| 0 | 3-Wire Control | | | | | |
| 1 | Local/Remote Selection | | | | | |
| 2 | Option/Inverter Selection | | | | | |
| 3 | Multi-Step Ref. 1 (<i>factory default, H1-03</i>) | | | | | |
| 4 | Multi-Step Ref. 2 (<i>factory default, H1-04</i>) | | | | | |
| 5 | Multi-Step Reference 3 | | | | | |
| 6 | Jog Frequency Ref. (<i>factory default, H1-05</i>) | | | | | |
| 7 | Multi-Accel/Decel 1 | | | | | |
| 8 | Ext. Baseblock N.O. (<i>factory default, H1-06</i>) | | | | | |
| 9 | External Baseblock N.C. | | | | | |
| A | Accel/Decel Ramp Hold | | | | | |
| B | OH2 Alarm Signal | | | | | |
| C | Terminal 16 Enable | | | | | |
| D | V/f Mode Selection | | | | | |
| E | ASR Integral Reset | | | | | |
| 10 | MOP Increase | | | | | |
| 11 | MOP Decrease | | | | | |
| 12 | Forward Jog | | | | | |
| 13 | Reverse Jog | | | | | |
| 14 | Fault Reset (<i>factory default, H1-02</i>) | | | | | |
| 15 | Fast-Stop | | | | | |
| 16 | Motor 2 Select | | | | | |
| 17 | Fast-Stop (Closed, motor decels by C1-09) | | | | | |
| 18 | Timer Function | | | | | |
| 19 | PID Disable | | | | | |
| 1A | Multi-Accel/Decel 2 | | | | | |

| | | | | | | |
|-------|--|--|--|--|--|--|
| 1B | Program Lockout | | | | | |
| 1C | Trim Control Increase | | | | | |
| 1D | Trim Control Decrease | | | | | |
| 1E | Reference Sample Hold | | | | | |
| 1F | Terminal 13/14 Switch | | | | | |
| 20-2F | External Fault (<i>factory default, H1-01</i>) | | | | | |
| 30 | Closed: PID Integral is Reset | | | | | |
| 31 | Closed: PID Integral Value is Held <1110> | | | | | |
| 60 | DC Injection Activate | | | | | |
| 61 | Speed Search 1 | | | | | |
| 62 | Speed Search 2 | | | | | |
| 63 | Energy Saving Command | | | | | |
| 64 | Speed Search 3 | | | | | |
| 65 | KEB Ridethrough N.C. | | | | | |
| 66 | KEB Ridethrough N.O | | | | | |
| 71 | Speed/Torque Control Change | | | | | |
| 72 | Zero Servo Command | | | | | |
| 77 | ASR Gain Switch | | | | | |

- 3-Wire Control (setting: "0")
 When *H1-__* is set to "0", 3-wire control is enabled. The terminal set to "0" becomes the FWD/REV run command.

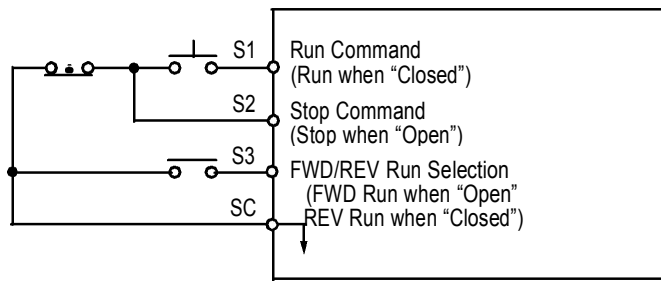

Figure 31 Terminal Function at 3-Wire Sequence Selection (*H1-__* = "0")

· Local/Remote Selection (setting: "1")

Selects the operation mode, only when the inverter is stopped.

Local: Operation according to frequency reference and run command from digital operator. Remote: Operation according to frequency reference and run command set by *B1-01* and *B1-02*, respectively.

Note: When local/remote selection is set by a multi-function contact input terminal, local/remote selection from the digital operator key is disabled.

· Option/Inverter Selection (setting: "2")

Selects whether operation is performed using a reference command from an option card or from the inverter. Selection is effective only when the inverter is stopped.

Open: Runs by frequency reference and run command from inverter control circuit terminal or digital operator.

Closed: Runs by frequency reference and run command from an option card.

Multi-Step Ref 1 through 3 and Jog Freq Ref (Set value = 3, 4, 5, and 6)

| Terminal 8 (H1-06 = 6) Jog Freq Ref | Terminal 7 (H1-05 = 5) Multi-Step Ref 3 | Terminal 6 (H1-04 = 4) Multi-Step Ref 2 | Terminal 5 (H1-03 = 3) Multi-Step Ref 1 | Preset Reference |
|---|---|---|---|-----------------------|
| O | O | O | O | Reference 1 (d1-01) |
| O | O | O | X | Reference 2 (d1-02) |
| O | O | X | O | Reference 3 (d1-03) |
| O | O | X | X | Reference 4 (d1-04) |
| O | X | O | O | Reference 5 (d1-05) |
| O | X | O | X | Reference 6 (d1-06) |
| O | X | X | O | Reference 7 (d1-07) |
| O | X | X | X | Reference 8 (d1-08) |
| X | --- | --- | --- | Jog Reference (d1-09) |

O - Open

X - Closed

-- Has no effect

d1-01 is effective when b1-01 is set to 0 (reference from the digital operator)

d1-02 is effective when the terminal 16 setting (H3-05) is set to anything other than zero.

It is possible to mix analog and digital references in the multi-speed input function. The parameters must be set as shown below

| Parameter | Reference | Digital | Analog |
|-----------|---------------|-----------|-------------------------------|
| (d1-01) | Reference 1 | b1-01 = 0 | b1-01 = 1 (terminal 13 or 14) |
| (d1-02) | Reference 2 | H3-05 = 0 | H3-05 = 0 (terminal 16) |
| (d1-03) | Reference 3 | d1-03 | not available |
| (d1-04) | Reference 4 | d1-04 | |
| (d1-05) | Reference 5 | d1-05 | |
| (d1-06) | Reference 6 | d1-06 | |
| (d1-07) | Reference 7 | d1-07 | |
| (d1-08) | Reference 8 | d1-08 | |
| (d1-09) | Jog Reference | d1-09 | |

· Multi Accel/Decel (Set value = 7)

Open: Acceleration 1 / Deceleration 1 is set by parameters C1-01 and C1-02 respectively.

Closed: Acceleration 2 / Deceleration 2 is set by parameters C1-03 and C1-04 respectively.

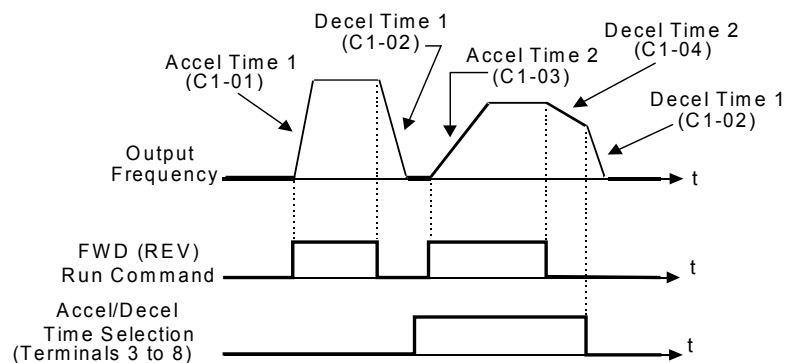

· External Baseblock N.O. (setting: "8")

Baseblock operation is performed when the contact output is closed. External baseblock operation differs as described below, depending on the run command input status.

When an external baseblock signal is input while the inverter is running, BB blinks on the digital operator display, and the inverter output is shut OFF. When the external baseblock signal is removed, operation restarts at the previous frequency reference before baseblock. Output voltage is then increased up to its previous level before baseblock, in the voltage recovery time (L2-04).

When a stop signal is input and an external baseblock signal is input while the inverter is decelerating, BB blinks on the digital operator, the inverter output shuts OFF and the frequency reference is set to 0.

- External Baseblock N.C. (setting: “9”)

Baseblock operation is performed similar to setting “8”, except that operation is performed when the contact output is closed.

- Accel/Decel Hold Command (setting: “A”)

The accel/decel hold command is used to temporarily hold the output frequency at the current frequency reference, when the hold command is input. When a stop command is input, the accel/decel hold condition is released and operation stops.

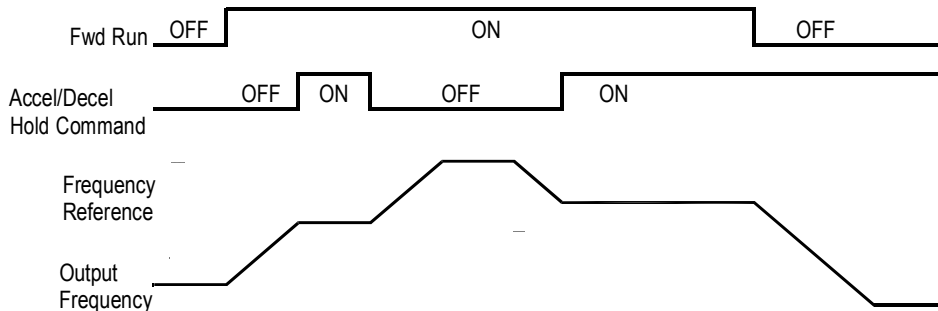

Figure 32 Accel/Decel Hold Command Timing Diagram

Notes:

1. When hold reference memory selection is enabled ($D4-01 = "1"$) and an accel/decel hold command is input, by inputting a run command again after a stop command is input, the held output frequency is stored unless the accel/decel stop command is released. Operation resumes at the stored frequency.
2. When the power supply is turned OFF after the accel/decel hold command is input, the held output frequency is also stored.
3. When $D4-01$ is set to “0”, the held output frequency is not stored,

- Inverter Overheat OH2 Alarm (setting: “B”)

When the inverter overheat alarm signal is input, OH2 blinks on the digital operator display. This contact can be connected to an external temperature switch for monitoring the inverter ambient temperature. A multi-function contact output ($H2- _$) can be set to “20” to close a contact at this condition.

- Multi-function Analog Input Selection (setting: “C”)

This setting disables the terminal 16 multi-function analog input.

Open: Terminal 16 command is not accepted.
Closed: Terminal 16 command is accepted.

- Feedback Mode During V/f Selection (setting: “D”)

Feedback input can be disabled while the inverter is running when this function is selected. However, the speed control integral value ($C5-05$) is held until stop.

Open: Feedback control enabled (closed loop)
Closed: Feedback control disabled (open loop)

This function is available only during V/f control with PG feedback.

· Speed Control Integral Value Reset (setting: “E”)

The speed control integral value can be reset while the inverter is running when this function is selected. Reset is effective only when integral control selection during accel/decel ($F1-07$) = “0”.

Open: PI-control (speed control integral values are added.)

Closed: P-control (speed control integral values are reset by the integral time constant.)

· Up/Down Command (settings: Up = “10”. Down = “11”)

With the FWD (REV) run command entered, a change in frequency is performed by inputting the Up or Down signals to any two contact inputs, so that operation can be performed at the desired speed.

| | | | | |
|------------------|--------|--------|------|--------|
| UP command | Closed | Open | Open | Closed |
| DOWN command | Open | Closed | Open | Closed |
| Operation Status | Accel | Decel | Hold | Hold |

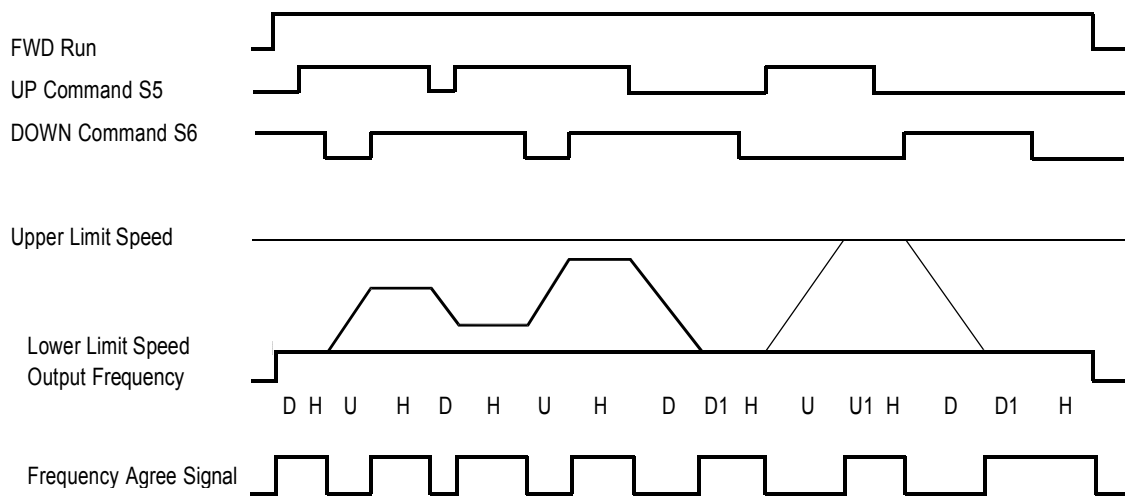

- U: Up (accelerating) status
- D: Down (decelerating) status
- H: Hold (constant speed) status
- U1: Up status, with clamping at upper limit speed
- D1: Down status, with clamping at lower limit speed

Figure 33 UP/DOWN Command Timing Diagram

Notes:

1. Be sure to set frequency reference selection ($B1-01$) = “1”. When $B1-01$ = “0”, Up/Down operation is disabled.
2. Upper limit speed
= Max. output frequency ($E1-04$) \times Frequency reference upper limit ($D2-01$), if used
3. The lower limit value is either the master frequency reference from control circuit terminals 13 or 14, or the frequency reference lower limit ($D2-01$), whichever is larger.
4. When hold reference memory selection is enabled ($D4-01$ = “1”) and a hold command is input, the held output frequency is stored even after the power supply is turned OFF. When $D4-01$ = “0”, the held output frequency is *not* stored.
5. If the jog frequency reference is input during Up/Down operation, the jog frequency reference has priority.

- Forward and Reverse JOG commands (settings: Fwd Jog = “12”, Rev Jog = “13”) Forward and reverse run jog frequency commands are enabled.

| Setting | Description |
|---------|--|
| 12 | Forward jog command is closed, run at jog frequency reference (D1-09). |
| 13 | Reverse jog command is closed, run at jog frequency reference (D1-09). |

Notes:

1. When either the forward or reverse jog command is input during run, this command has priority.
2. When both the forward and reverse jog commands are closed for more than 500ms, the inverter stops according to the stopping method selection (BI-03).
3. The forward and reverse jog commands can be set independently.

- Fault Reset (setting: “14”)

Closing this contact resets a fault after the condition is removed.

- Fast-Stop (Set value = 15)

Open: The inverter operates normally.

Closed: The inverter decelerates to stop using deceleration time C1-09 (factory set to 10 sec.). The run command can remain closed during this period of time. The inverter will not run, from the external terminals or the digital operator as long as this input is closed.

To restart the inverter, the run command must be cycled.

- Motor 2 Select (Set value = 16) Open:

Motor 1 is selected. Closed: Motor 2 is selected.

When Motor 2 is selected, the following parameters are effective;

The inverter must be stopped to switch motors.

A multi-function digital output may be programmed when motor 2 is selected. Refer to page 88 for more information.

- Fast-Stop (setting: “17”) <1110>

When this input is closed the motor decelerates to a stop using the rate defined by parameter C1-09.

- Timer Function (Set value = 18)

The timer function works independently from the inverter.

The timer input must be on longer than the time in b4-01 for the output to close.

The timer input must be off longer than the time in b4-02 for the output to open.

b4-01 is the on-delay time setting (0.0 - 300.0 second)

b4-02 is the off-delay time setting (0.0 - 300.0 second)

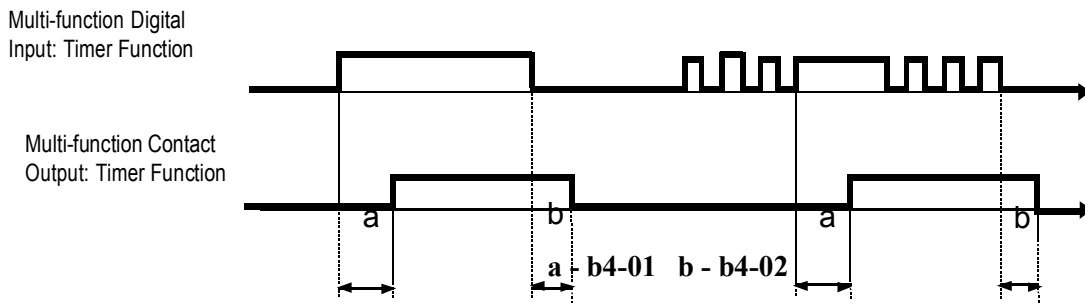

- PID Disable (Set value = 19) Open: PID control is enabled. Closed: PID control is disabled

- Program Lockout (setting: "1B") Opening this contact prohibits the changing of VS-616G5 parameters.

- TrimCtl Increase (Set value = 1C)
- TrimCtl Decrease (Set value 1D)

Closed: Increases or decreases the output frequency based on the setting of d4-02 (trim control level). This function is not available when the reference is set from the digital operator.

- Analog Reference Sample/Hold Selection (setting: "1E")

If the contact input closes for 100ms or longer, the analog frequency reference is sampled once, after which the analog frequency reference is held.

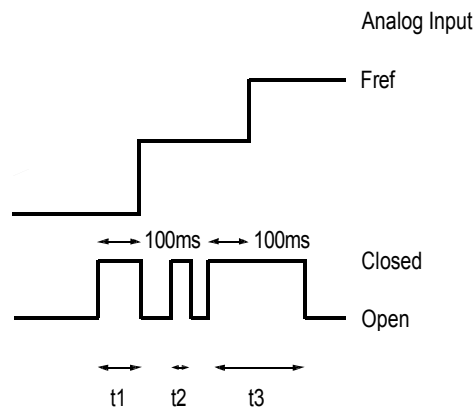

Figure 34 Sample/Hold Selection - Analog Reference

Note: t1, t3 - Reference is held at 100ms or longer.
 t2 - Reference is *not* held at less than 100ms.

· Terminal 13/14 Selection (setting: “1F”)

Open: Terminal 13 is used for the master frequency reference.
 Closed: Terminal 14 is used for the master frequency reference.

Note: When the set value of Terminal 14 Selection (*H3-09*) is other than “1F” and the contact input is set for terminal 13/14 selection (*H1-__* = “1F”), a setting error (OPE3) occurs.

· External Fault (setting: “20-2F”)

Use this contact input to select how the inverter responds to an external fault.

| External Fault Selection | | | | | | | | Setting Result |
|--------------------------|------|------------------|------------|-----------------------|---------------|-----------|------------|----------------|
| Input Level Selection | | Detection Method | | External Fault Action | | | | |
| N.O. | N.C. | Always | During Run | Ramp to Stop | Coast to Stop | Fast-stop | Alarm Only | |
| | | | | | | | | 20 |
| | | | | | | | | 24 |
| | | | | | | | | 28 |
| | | | | | | | | 2C |
| | | | | | | | | 22 |
| | | | | | | | | 26 |
| | | | | | | | | 2A |
| | | | | | | | | 2E |
| | | | | | | | | 21 |
| | | | | | | | | 25 |
| | | | | | | | | 29 |
| | | | | | | | | 2D |
| | | | | | | | | 23 |
| | | | | | | | | 27 |
| | | | | | | | | 2B |
| | | | | | | | | 2F |

Notes:

1. N.O. = normally open contact; N.C. = normally closed contact
2. Setting “24” is the factory default.
3. Set up the external fault function according to the following tree:

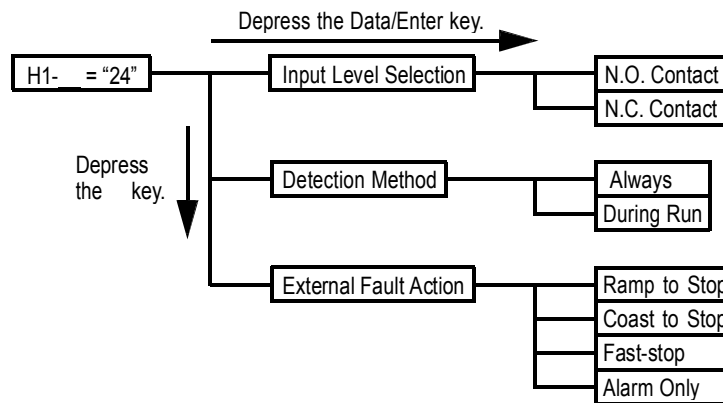

- PID Integral reset (Set value = 30)
Open: PID Integral values are added. Closed: PID Integral value is set to zero.

- PID Control Integral Hold (Set value = 31) <1110>
Closed: Integral value of the PID control is held.

- DC Injection Braking Command (setting: "60")
When a DC injection braking command is input while the inverter is stopped, DC injection braking operation is activated. When a run command or a jog command is input, DC injection braking is released to start operation (operation has priority).

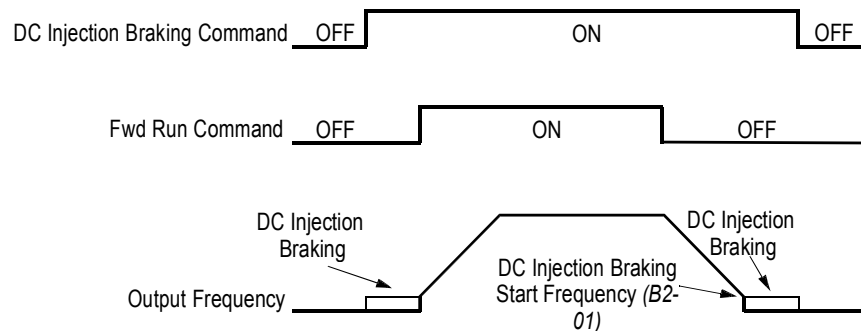
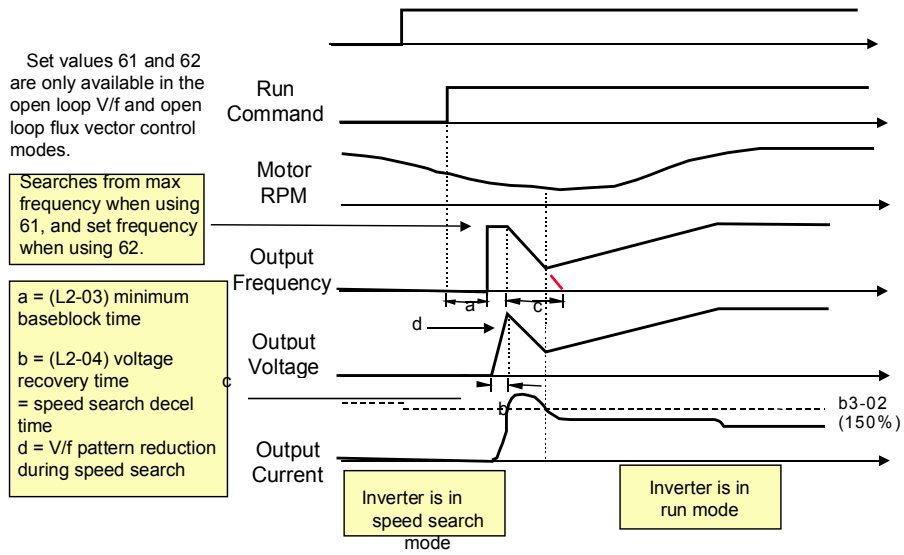

Figure 35 DC Injection Braking Contact Input Timing Diagram

·Speed Search 1 and Speed Search 2 (Set value = 61 and 62)



· Energy Save Mode (Set value = 63)

After the energy savings input is closed and the output frequency is equal to or greater than (b8-02) energy savings start frequency, the output voltage drops to the value in (b8-01) energy savings gain. The output voltage increases and decreases based on L2-04 (voltage recovery time).

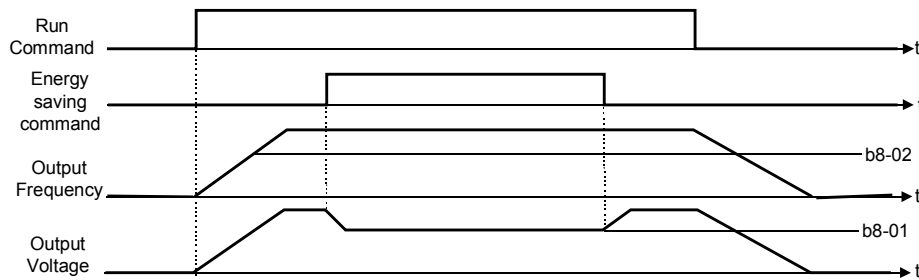

· Speed Search 3 (Set value = 64)

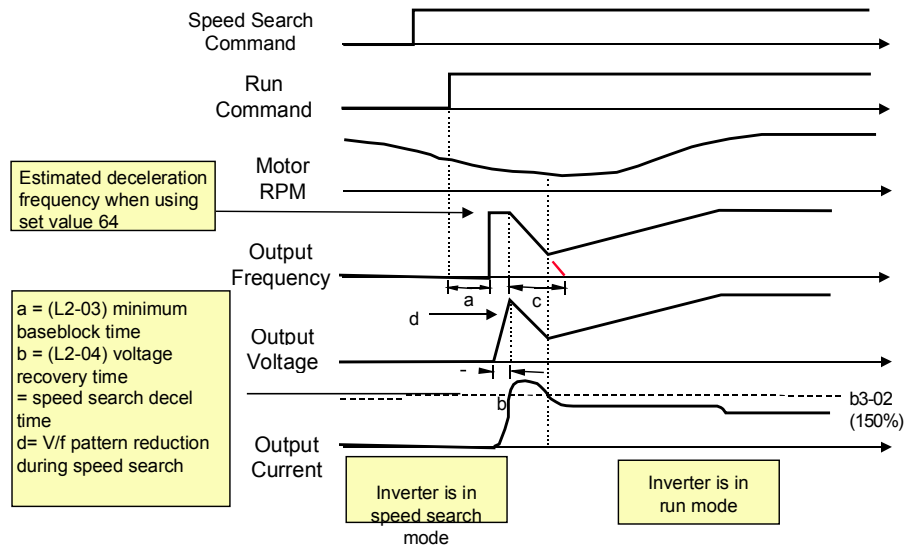

· KEB Ridethrough (settings: N.C. = “65”, N.O. = “66”)

In general applications, the Kinetic Energy Braking (KEB) control circuit attempts to maintain the DC bus voltage at an optimum level [$1.35 \times$ input voltage ($E1-01$)] during momentary power loss, by using load inertia to regenerate voltage back to the DC bus. The inverter decelerates at the fast-stop rate ($C1-09$), until power is restored, or until the time runs out and an undervoltage fault (UV) occurs. The larger the inertia, the longer the deceleration rate can be extended. If the inertia is small, then the inverter must decelerate quickly to regenerate voltage back to the DC bus, and thus the ride-through time is shorter. For most applications, set KEB Frequency Constant ($L2-06$) to “0” (factory default).

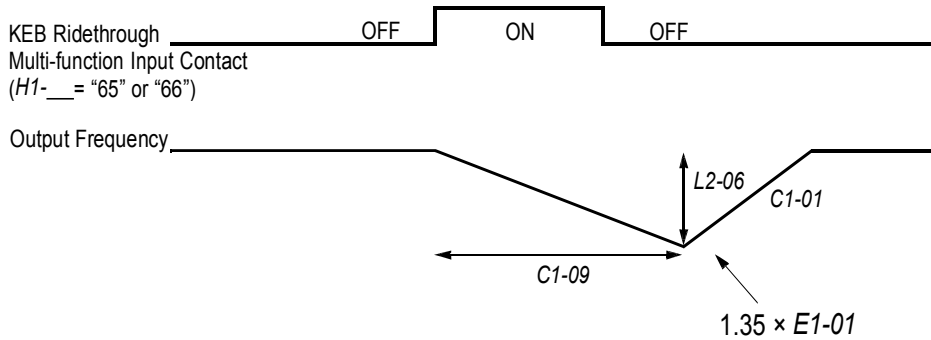

Figure 36 KEB Ridethrough Timing Diagram

Note: Larger model inverters (2022 and above, 4018 and above) require a separate uninterruptible power supply (UPS) for control power, in order for load inertia ridethrough to be effective.

H2 Digital Outputs

The FST-800 Series has three multi-function contact outputs for the indication of various conditions, including frequency detection, speed agree, zero speed, overtorque detection, and many others. This section includes descriptions of these functions.

- H2-01 Multi-function Output 1 Selection (terminal 9, 10) Terminal 9 Sel
- H2-02 Multi-function Output 2 Selection (terminal 25, 27) Terminal 25 Sel
- H2-03 Multi-function Output 3 Selection (terminal 26, 27) Terminal 26 Sel

| | | | |
|---|---|---|---|
| B | B | B | B |
| B | B | B | B |
| B | B | B | B |

The following table lists the function selections for the multi-function contact outputs (terminals 9, 25 and 26), and indicates the control modes during which each function can be enabled.

| H2-01 to 3 Setting | Function | Control Method (A1-02) | | | | Reference Page |
|--------------------------|--|------------------------|-----------|---------------------|-------------|-------------------|
| | | V/f | V/f w/ PG | Open Loop Vector | Flux Vector | |
| 0 | During run 1 (factory default, H2-01) | | | | | |
| 1 | Zero-speed (factory default, H2-02) | | | | | |
| 2 | Frequency agree 1 (factory default, H2-03) | | | | | |
| 3 | Desired frequency agree 1 | | | | | |
| 4 | Frequency detection 1 | | | | | |
| 5 | Frequency detection 2 | | | | | |
| 6 | Inverter ready | | | | | |
| 7 | DC bus undervoltage | | | | | |
| 8 | Baseblock 1 | | | | | |
| 9 | Option reference | | | | | |
| A | Remote operation | | | | | |
| B | Torque detection 1 (N.O.) | | | | | |
| C | Loss of reference | | | | | |
| D | DB overheat | | | | | |
| E | Fault | | | | | |
| F | Not used | | | | | |
| 10 | Minor fault | | | | | |
| 11 | Reset command active | | | | | |
| 12 | Timer output | | | | | |
| 13 | Frequency agree 2 | | | | | |
| 14 | Desired frequency agree 2 | | | | | |
| 15 | Frequency detection 3 | | | | | |
| 16 | Frequency detection 4 | | | | | |
| 17 | Torque detection 1 (N.C.) | | | | | |
| 18 | Torque detection 2 (N.O.) | | | | | |
| 19 | Torque detection 2 (N.C.) | | | | | |
| 1A | Reverse direction | | | | | |
| 1B | Baseblock 2 | | | | | |
| 1C | Motor 2 Selection | | | | | |
| 1D | Regenerating | | | | | |
| 1E | Restart enabled | | | | | |
| 1F | Overload (OL1) | | | | | |
| 20 | OH pre-alarm | | | | | |
| 30 | Current/torque limit | | | | | |
| 31 | Speed limit | | | | | |
| 33 | Zero servo completion | | | | | |
| 37 | During run 2 | | | | | |

- During Run (setting: “0”)
 - Closes when a run command is input, or when the inverter outputs voltage.
- Zero-speed (setting: “1”)
 - Closes when the inverter output frequency is less than the minimum output frequency (E1-09) during V/f control with PG feedback. Closes when the motor speed is less than the zero-speed level (B2-01) during flux vector control.

- Frequency Agree 1 (setting: “2”)

Closes whenever the output frequency “agrees” with the frequency reference, plus or minus the speed agree detection width (L4-02). This is effective during both forward *and* reverse operation.

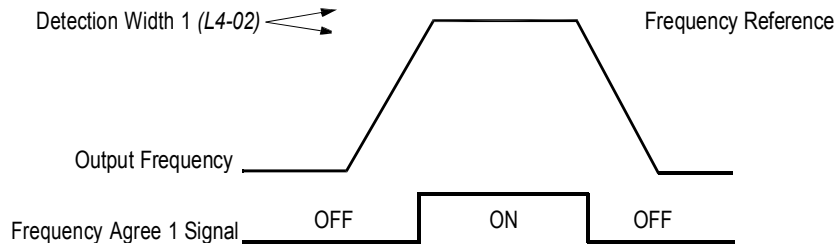

Figure 37 Frequency Agree Signal 1 Timing Diagram

- Desired Frequency Agree 1 (setting: “3”)

Closes whenever the output frequency “agrees” with the speed agree detection level (L4-01), plus or minus the speed agree detection width (L4-02). This is effective during both forward *and* reverse operation.

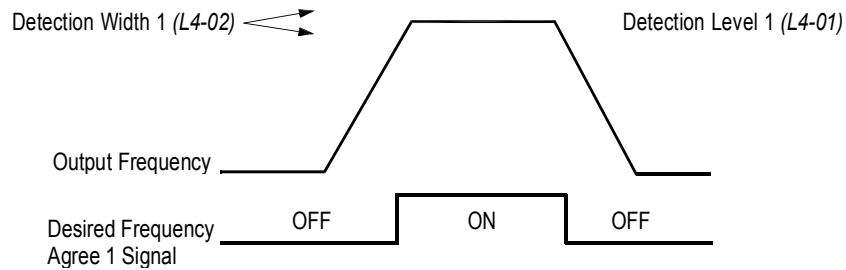

Figure 38 Desired Frequency Agree 1 Signal Timing Diagram

- Frequency Detection 1 (setting: “4”)

Closes whenever the output frequency is at or below the speed agree detection level (L4-01). During acceleration from below the detection level, the output frequency increases through the detection bandwidth (L4-02) before the contact opens again. This is effective during both forward and reverse operation.

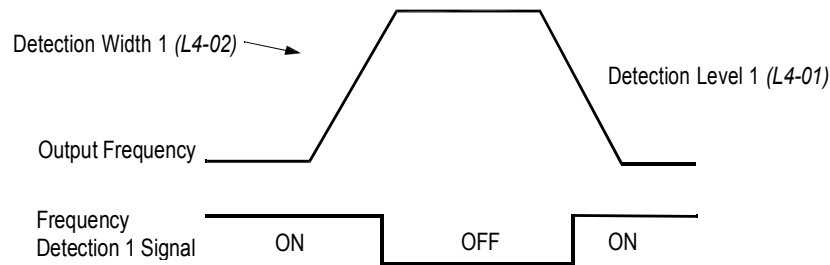

Figure 39 Frequency Detection 1 Signal Timing Diagram

- Frequency Detection 2 (setting: “5”)

Closes whenever the output frequency is at or above the speed agree detection level (*L4-01*). During deceleration from above the detection level, the output frequency decreases through the detection bandwidth (*L4-02*) before the contact opens again. This is effective during both forward *and* reverse operation.

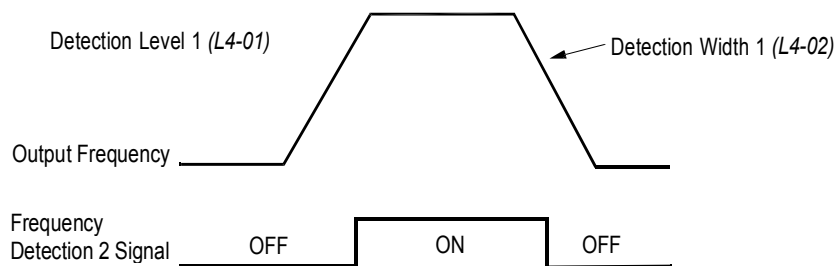

Figure 40 Frequency Detection 2 Signal Timing Diagram

- Inverter Ready (setting: “6”)

Closes when the inverter is ready for operation (no faults or alarms).

- DC Bus Undervoltage (setting: “7”)

Closes when the main circuit DC bus voltage or control circuit power supply is drops below the trip level, or when the main circuit magnetic contactor (MC) turns OFF.

- Baseblock 1 - N.O. (setting: “8”)

Closes when the inverter output shuts OFF.

- Frequency Reference Selection (setting: “9”)

Opens when the frequency reference is input from the control circuit terminals or an option. Closes when the frequency reference is input from the digital operator.

- Run Command Selection (setting: “A”)

Opens when run command is input from the control circuit terminals or an option. Closes when run command is input from the digital operator.

- Overtorque Detection 1 - N.O. (setting: “B”)

Closes during overtorque detection 1 (see section **L6, Overtorque Detection**, on page 113).

- Loss of Frequency Reference (setting: “C”)

Closes when frequency reference is reduced by 90% within 400ms. The inverter will respond according to the setting of reference loss selection (*L4-05*). After reference loss, if *L4-05* = “1”, then operation continues at 80% of the previous frequency reference, and the contact closes.

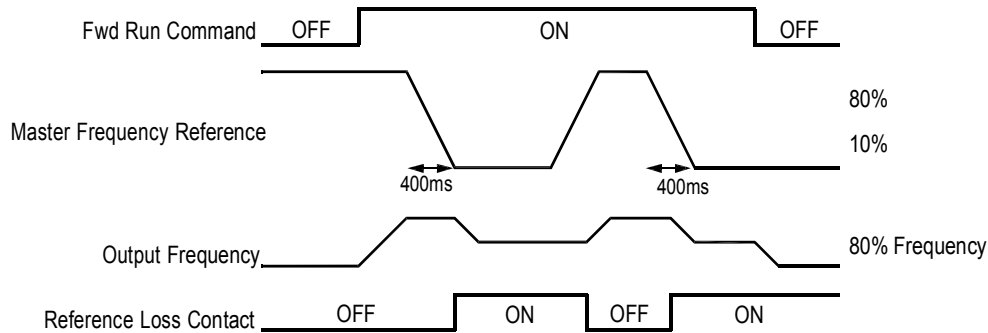

Figure 41 Reference Loss Timing Diagram

- Dynamic Braking Resistor Overheat (setting: “D”)

Closes during braking resistor overheating or a braking transistor fault.

- Fault (setting: “E”)

Closes when a fault occurs (except CPF00 and CPF01).

- Alarm (setting: “10”)

Closes while an alarm is displayed.

- Fault Reset (setting: “11”)

Closed while fault is being reset.

- Timer Output (setting: “12”)

Closes when timer contact input closes (after On-delay time elapses).

Opens when timer contact input opens (after Off-delay time elapses).

- Frequency Agree 2 (setting: “13”)

Closes whenever the output frequency “agrees” with the frequency reference, plus or minus the speed agree detection width (*L4-04*). This is used for setting up an alternate detection width.

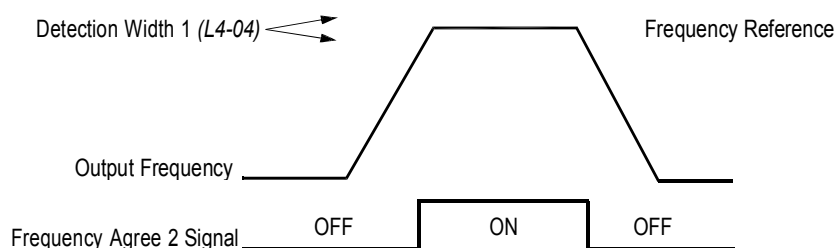

Figure 42 Frequency Agree Signal 2 Timing Diagram

· Desired Frequency Agree 2 (setting: “14”)

Closes whenever the output frequency “agrees” with the speed agree detection level (L4-03), plus or minus the speed agree detection width (L4-04). Choose forward or reverse operation in L4-03.

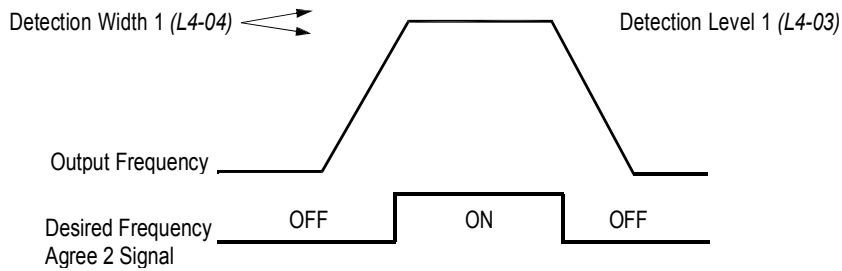

Figure 43 Desired Frequency Agree 2 Signal Timing Diagram

· Frequency Detection 3 (setting: “15”)

Closes whenever the output frequency is at or below the speed agree detection level (L4-03). During acceleration from below the detection level, the output frequency increases through the detection bandwidth (L4-04) before the contact opens again. Choose forward or reverse operation in L4-03.

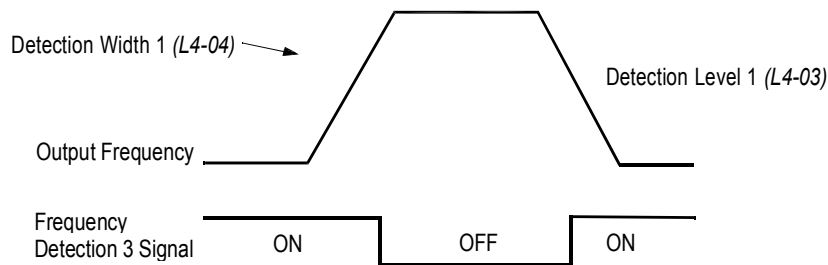

Figure 44 Frequency Detection 3 Signal Timing Diagram

· Frequency Detection 4 (setting: “16”)

Closes whenever the output frequency is at or above the speed agree detection level (L4-03). During deceleration from above the detection level, the output frequency decreases through the detection bandwidth (L4-04) before the contact opens again. Choose forward or reverse operation in L4-03.

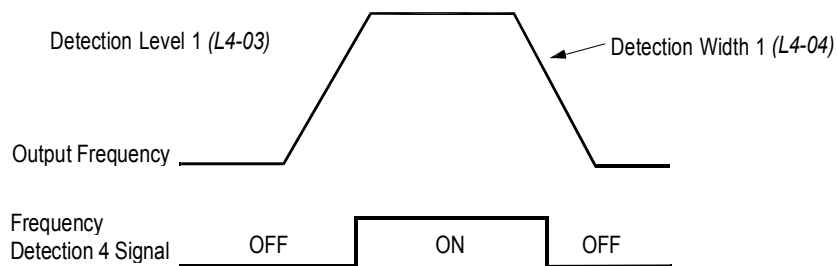

Figure 45 Frequency Detection 2 Signal Timing Diagram

- Overtorque Detection 1 - N.C. (setting: "17")
Closes during overtorque detection 1 (see section **L6, Overtorque Detection**, on page 113).
- Overtorque Detection 2 - N.O. (setting: "18")
Closes during overtorque detection 2 (see section **L6, Overtorque Detection**, on page 113).
- Overtorque Detection 2 - N.C. (setting: "19")
Opens during overtorque detection 2 (see section **L6, Overtorque Detection**, on page 113).
- During Reverse Run (setting: "1A") Closes
during a reverse run command.
- Baseblock 2 - N.C. (setting: "1B")
Opens when the inverter output shuts OFF.
- Motor 2 Selection (setting: "1C") Closed
when motor 2 is selected.
Motor 2 may be selected by using a multi-function digital input.
- Motoring/Regenerating Mode (setting: "1D")
Closes during regenerative operation (flux vector control only).
- Automatic Restart (setting: "1E")
Closes during automatic restart operation.
- OL1 Pre-alarm (setting: "1F")
Closes when the motor-calculated electronic thermal overload value increases to 90% of the internal fault detection level.
- OH Pre-alarm (setting: "20")
Closes when the heatsink temperature exceeds the overheat temperature level (*L8-02*), or when a multi-function contact input (*H1-__ = "B"*) closes.
- Current/Torque Limit (setting: "30") Closes
during torque limit.
- Speed Limit (setting: "31")
Closes when the speed limit level (*D5-03*) is reached during torque control (flux vector control).
- Zero-Servo Completion (setting: "33")
Closes when zero-servo operation is completed.
- During Run 2 (setting: "37")
Closes when a run command is input (does *not* close during baseblock, injection braking or initial excitation).

H3 Analog Inputs

The FST-800 series has three analog inputs (two multi-function and one reference), for the external input of numerous references and limits, including frequency, torque, PID, and others. This section includes descriptions of these functions.

H3-01 Terminal 13 Signal Selection

Term 13 Signal

| | | | |
|---|---|---|---|
| B | B | B | B |
|---|---|---|---|

Selects the type of voltage signal input at terminal 13.

| Setting | Description |
|---------|---|
| 0 | 0 to 10V input (<i>factory default</i>) |
| 1 | -10 to +10V input |

The resolution of terminal 13 is 11 bit.

H3-02 Terminal 13 Reference % Gain

Terminal 13 Gain

| | | | |
|---|---|---|---|
| B | B | B | B |
|---|---|---|---|

Setting Range: 0.0 to 1000.0%
 Factory Default: 100.0%

Sets the terminal 13 input gain level when the reference voltage is 10V.

H3-03 Terminal 13 Reference ±% Bias

Terminal 13 Bias

| | | | |
|---|---|---|---|
| B | B | B | B |
|---|---|---|---|

Setting Range: -100.0 to 100.0%
 Factory Default: 0.0%

Sets the terminal 13 input bias level when the reference voltage is 0V.

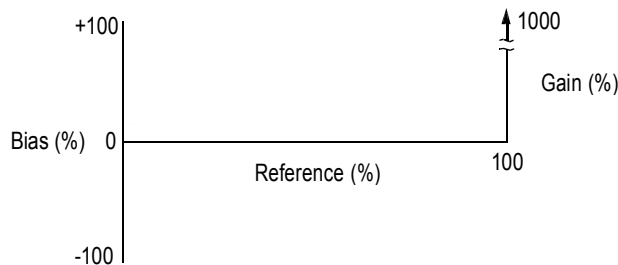

Figure 46 Analog Input Gain and Bias Adjustment

H3-04 Terminal 16 Signal Selection

Terminal 16 Sel

| | | | |
|---|---|---|---|
| B | B | B | B |
|---|---|---|---|

Selects the type of voltage signal input at terminal 16.

| Setting | Description |
|---------|----------------------------------|
| 0 | 0 to 10V input (factory default) |
| 1 | -10 to +10V input |

The resolution of terminal 16 is 11 bit.

H3-05 Terminal 16 Multi-function Selection

Terminal 16 Sel

| | | | |
|---|---|---|---|
| B | B | B | B |
|---|---|---|---|

The following table lists the function selections for the multi-function analog inputs (terminals 14 and 16), and indicates the control modes during which each function can be enabled.

| Setting | Function | Control Method (A1-02) | | | | Setting Level |
|---------|---------------------------------------|------------------------|-----------|------------------|-------------|---------------|
| | | V/f | V/f w/ PG | Open Loop Vector | Flux Vector | |
| 0 | Aux. Frequency Ref. (factory default) | | | | | ±100% / ±10V |
| 1 | Frequency Gain | | | | | 100% / 10V |
| 2 | Frequency Bias | | | | | ±100% / ±10V |
| 4 | Voltage Bias | | | | | 100% / 10V |
| 5 | Accel/Decel Change | | | | | 100% / 1V |
| 6 | DC Injection Braking Current | | | | | 100% / 10V |
| 7 | Overtorque Level | | | | | 100% / 10V |
| 8 | Stall Prevention Level | | | | | 100% / 10V |
| 9 | Reference Lower Limit | | | | | 100% / 10V |
| A | Jump Frequency | | | | | 100% / 10V |
| B | PID Feedback | | | | | ±100% / ±10V |
| C | PID Reference Bias <1110> | | | | | 10V/Fmax |
| D | Frequency Reference Bias 2 <1110> | | | | | 10V/Fmax |
| 10 | Forward Torque Limit | | | | | 100% / ±10V |
| 11 | Reverse Torque Limit | | | | | 100% / ±10V |
| 12 | Regenerative Torque Limit | | | | | 100% / ±10V |
| 13 | Torque Reference | | | | | ±100% / ±10V |
| 14 | Torque Compensation | | | | | ±100% / ±10V |
| 15 | Forward/Reverse Torque Limit | | | | | ±100% / 10V |
| 1F | Not Used | | | | | |

- Auxiliary Frequency Reference (setting: "0")
- Frequency Bias (setting: "2")
- PID Feedback (setting: "B")
- Torque Reference (setting: "13")
- Torque Compensation (setting: "14")

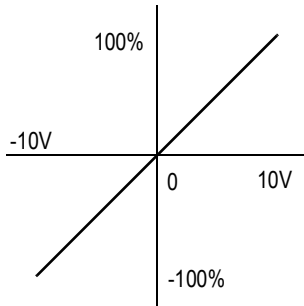

- Frequency Gain (setting: "1")
- Voltage Bias (setting: "4")
- DC Injection Braking Current (setting: "6")
- Overtorque Level (setting: "7")
- Reference Lower Limit (setting: "9")
- Jump Frequency (setting: "A")

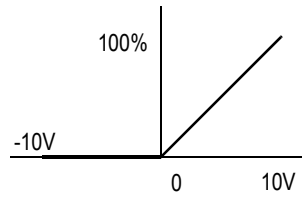

- Forward/Reverse Torque Limit (setting: "15")

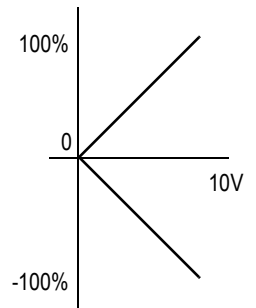

- Accel/Decel Change (setting: "5")

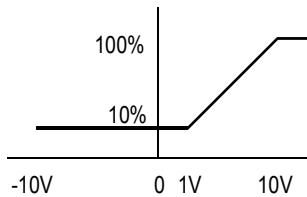

- Stall Prevention Level (setting: "8")

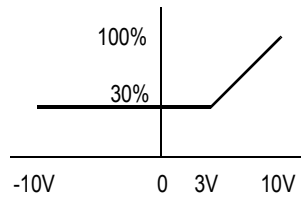

- Forward Torque Limit (setting: "10")
- Reverse Torque Limit (setting: "11")
- Regenerative Torque Limit (setting: "12")

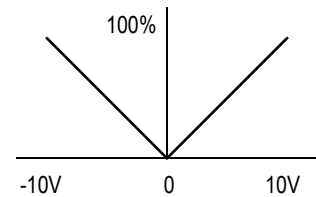

Figure 47 Multi-function Analog Input Selection

H3-06 Terminal 16 Reference % Gain

Terminal 16 Gain

| | | | |
|---|---|---|---|
| B | B | B | B |
|---|---|---|---|

Setting Range: 0.0 to 1000.0%
 Factory Default: 100.0%

Sets the terminal 16 input gain level when the reference voltage is 10V. See Figure 46, on page 95.

H3-07 Terminal 16 Reference ±% Bias

Terminal 16 Bias

| | | | |
|---|---|---|---|
| B | B | B | B |
|---|---|---|---|

Setting Range: -100.0 to 100.0%
 Factory Default: 0.0%

Sets the terminal 16 input bias level when the reference voltage is 0V. See Figure 46, .

H3-08 Terminal 14 Signal Selection

Term 14 Signal

| | | | |
|---|---|---|---|
| A | A | A | A |
|---|---|---|---|

Selects the type of signal input at terminal 14.

| Setting | Description |
|---------|--------------------------------------|
| 0 | 0 to 10V input |
| 1 | -10 to +10V input |
| 2 | 4 to 20mA (<i>factory default</i>) |

The resolution of terminal 14 is 10 bit.

Note: To enable terminal 14 for a voltage signal (settings: “0” or “1”), cut jumper wire J1 on the control printed circuit board. J1 is located on the bottom left-hand corner of the control board directly behind terminal 13.

H3-09 Terminal 14 Multi-function Selection

Terminal 14 Sel

| | | | |
|---|---|---|---|
| A | A | A | A |
|---|---|---|---|

Selects the multi-function analog input function for terminal 14 (see Terminal 16 Multi-function Selection for details).

H3-10 Terminal 14 Reference % Gain

Terminal 14 Gain

| | | | |
|---|---|---|---|
| A | A | A | A |
|---|---|---|---|

Setting Range: 0.0 to 1000.0%
 Factory Default: 100.0%

Sets the terminal 14 input gain level when the reference current is 20mA. See Figure 46, on page 95.

H3-11 Terminal 14 Reference ±% Bias

Terminal 14 Bias

| | | | |
|---|---|---|---|
| A | A | A | A |
|---|---|---|---|

Setting Range: -100.0 to 100.0%
 Factory Default: 0.0%

Sets the terminal 14 input bias level when the reference current is 4mA. See Figure 46, on page 95.

H3-12 Analog Input Filter Time Constant

Filter Avg Time

| | | | |
|---|---|---|---|
| A | A | A | A |
|---|---|---|---|

Setting Range: 0.00 to 2.00s
 Factory Default: 0.00s

Sets up a delay filter time constant at terminals 13, 14 and 16. This filter inserts a delay between the time the command is input to the time it is received by the inverter.

H4 Analog Outputs

The FST-800 Series has two analog outputs, for the external monitoring of drive conditions such as output frequency, output current, PID feedback and others.

H4-01 Terminal 21 Analog Output Selection

Terminal 21 Sel

| | | | |
|---|---|---|---|
| B | B | B | B |
|---|---|---|---|

Selects the analog output monitors for terminal 21.

| Setting | Descriptio |
|---------|---|
| 1 | Frequency reference |
| 2 | Output frequency (<i>factory default</i>) |
| 3 | Inverter output current |
| 5 | Motor speed |
| 6 | Output voltage |
| 7 | DC bus voltage |
| 8 | Output power |
| 9 | Torque reference (internal) |
| 15 | Terminal 13 input voltage level |
| 16 | Terminal 14 input voltage or current level |
| 17 | Terminal 16 input voltage level |
| 18 | Motor secondary current (Iq) |
| 19 | Motor excitation current (Id) |
| 20 | SFS output frequency |
| 21 | ASR input |
| 22 | ASR output |
| 23 | Speed deviation |
| 24 | PID feedback |
| 26 | Voltage reference (Vq output) |
| 27 | Voltage reference (Vd output) |
| 32 | ACR (q) Output |
| 33 | ACR (d) Output |
| 36 | PID Input Monitor <1110> |
| 37 | PID Output Monitor<1110> |
| 38 | PID Setpoint Monitor <1110> |

The resolution of terminal 21 is 9 bit plus sign.

H4-02 Terminal 21 Analog Output Gain

Terminal 21 Gain

| | | | |
|---|---|---|---|
| B | B | B | B |
|---|---|---|---|

Setting Range: 0.00 to 2.50
 Factory Default: 1.00

Sets the terminal 21 output gain for the analog output monitors. To obtain the output level, multiply the monitor output level by the gain value set in *H4-02*.

H4-03 Terminal 21 Analog Output Bias

Terminal 21 Bias

| | | | |
|---|---|---|---|
| B | B | B | B |
|---|---|---|---|

Setting Range: -10.0 to 10.0%
 Factory Default: 0.0%

Sets the terminal 21 output bias for the analog output monitors. To obtain the output level, multiply the monitor output level by the gain value set in *H4-02*, then add the bias value set in *H4-03*.

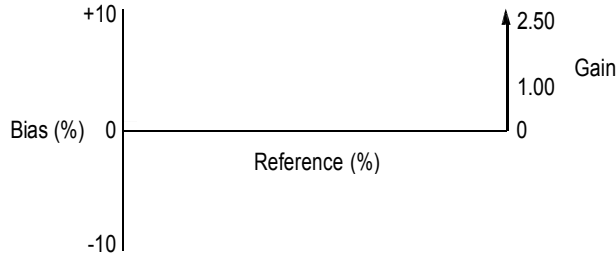

Figure 48 Analog Output Gain and Bias Adjustment

H4-04 Terminal 23 Analog Output Selection

Terminal 23 Sel

| | | | |
|---|---|---|---|
| B | B | B | B |
|---|---|---|---|

Selects the analog output monitors for terminal 23 (see Terminal 21 Analog Output Selection). The resolution of terminal 23 is 9 bit plus sign.

H4-05 Terminal 23 Analog Output Gain

Terminal 23 Gain

| | | | |
|---|---|---|---|
| B | B | B | B |
|---|---|---|---|

Setting Range: 0.00 to 2.50
 Factory Default: 1.00

Sets the terminal 23 output gain for the analog output monitors. To obtain the output level, multiply the monitor output level by the gain value set in *H4-05*. See Figure 48.

H4-06 Terminal 23 Analog Output Bias

Terminal 23 Bias

| | | | |
|---|---|---|---|
| B | B | B | B |
|---|---|---|---|

Setting Range: -10.0 to 10.0%
 Factory Default: 0.0%

Sets the terminal 23 output bias for the analog output monitors. To obtain the output level, multiply the monitor output level by the gain value set in *H4-05*, then add the bias value set in *H4-06*. See Figure 48.

H4-07 Analog Output Signal Selection

AO Level Select

| | | | |
|---|---|---|---|
| B | B | B | B |
|---|---|---|---|

Selects the type of voltage signal output at terminals 21 and 23.

| Setting | Description |
|---------|----------------------------------|
| 0 | 0 to 10V input (factory default) |
| 1 | -10 to +10V input |

H5 Serial Communication Set-up

The inverter uses communication port 6CN to communicate via MODBUS protocol.

H5-01 Serial Communication Station Address
Adr

Serial Comm

| | | | |
|---|---|---|---|
| A | A | A | A |
|---|---|---|---|

Setting Range: 0 to 1F

Factory Default: 1F

Selects a station address for identification of the inverter during serial communication.

H5-02 Serial Communication Baud Rate

Serial Baud Rate

| | | | |
|---|---|---|---|
| A | A | A | A |
|---|---|---|---|

Selects the baud rate at which the inverter serially communicates with external devices.

| Setting | Description |
|----------|---|
| 0 | 1200 Baud per Second |
| 1 | 2400 Baud per Second |
| 2 | 4800 Baud per Second |
| 3 | 9600 Baud per Second (<i>factory default</i>) |
| 4 | 19200 Baud <1110> |

H5-03 Serial Communication Parity Selection

Serial Com Sel

| | | | |
|---|---|---|---|
| A | A | A | A |
|---|---|---|---|

Selects the transmission parity for the 6CN MODBUS port.

| Setting | Description |
|----------|--------------------------------------|
| 0 | No parity (<i>factory default</i>) |
| 1 | Even parity |
| 2 | Odd parity |

H5-04 Stopping Method After Communication Error

Serial Fault Sel

| | | | |
|---|---|---|---|
| A | A | A | A |
|---|---|---|---|

Selects the stopping method after a transmission error is detected.

| Setting | Description |
|----------|---|
| 0 | Ramp to stop according to the time set in C1-02. |
| 1 | Fast-stop according to the time set in C1-09. |
| 2 | Coast to stop |
| 3 | Alarm only, continuous operation (<i>factory default</i>) |

H5-05 MODBUS Time Out Detection

Serial Fault Dtct

| | | | |
|---|---|---|---|
| A | A | A | A |
|---|---|---|---|

H5-05 enables or disables the MODBUS time out detection function. After initial communication begins, if communication is interrupted for longer than 2 seconds, then a communication fault will occur.

During a communication fault, the following fault code will be displayed: “CE Memobus Com Err”.

| Setting | Description |
|---------|--|
| 0 | Disabled - Time out detection is disabled. |
| 1 | Enabled - Time out detection is enabled. |

L Protection Parameters

L1 Motor Overload

The FST-800 Series protects against motor overload with a UL-recognized, built-in electronic thermal overload function.

L1-01 Motor Protection Fault Selection (OLI)

MOL Fault Select

| | | | |
|---|---|---|---|
| B | B | B | B |
|---|---|---|---|

Selects whether motor overload protection is provided.

| Setting | Description |
|---------|---|
| 0 | Motor overload detection is disabled. |
| 1 | Motor overload detection is enabled, motor coasts to stop (<i>factory default</i>). |

The electronic thermal overload function estimates motor temperature, based on inverter output current and time, to protect the motor from overheating. When the electronic thermal overload relay is activated, an “OL1” error occurs, shutting OFF the inverter output and preventing excessive overheating in the motor. As long as the inverter is powered up, it continues to calculate the motor temperature.

When operating with one inverter connected to one motor, an external thermal relay is not needed.

When operating several motors with one inverter, install a thermal relay on each motor. In this case, set parameter *L1-01* to “0”.

L1-02 Motor Protection Time Constant

MOL Time Const

| | | | |
|---|---|---|---|
| B | B | B | B |
|---|---|---|---|

Setting Range: 0.1 to 20.0 minutes <1110>
 Factory Default: 8.0 minutes

Sets the amount of time that the motor withstands 150% overload, when the motor is operated continuously at rated current. This value should be set according to the overload resistance of motors used.

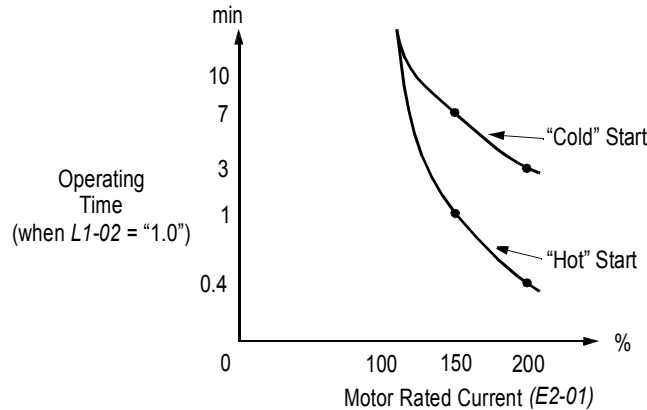

Figure 49 Electronic Thermal Overload Curve

Notes:

1. If the motor is running at 100% output current or less, the electronic thermal overload relay will *not* trip. (continued next page)
2. If the motor is run continuously at 150% output current, the electronic thermal overload relay will trip after one minute if the motor is started “hot”, and after eight minutes if the motor is started “cold”.

L2 Power Loss Ridethrough

When momentary power loss occurs, operation can restart automatically, according to the setting of the following parameters.

L2-01 Momentary Power Loss Ridethrough Selection PwrL Selection

| | | | |
|---|---|---|---|
| B | B | B | B |
|---|---|---|---|

Selects whether the inverter stops when power loss is detected or “rides through” a momentary power loss. When ridethrough operation is selected, speed search starts from the current output frequency.

| Setting | Description |
|---------|---|
| 0 | Momentary power loss ridethrough is disabled (<i>factory default</i>). When momentary power loss is detected, a fault contact trips, stopping the inverter. |
| 1 | Momentary power loss ridethrough is enabled, for the time set in L2-02. When momentary power loss is detected, a fault contact does <i>not</i> trip. If power is not restored within the time set in L2-02, a fault contact trips, stopping the inverter. |
| 2 | Momentary power loss ridethrough is enabled, within the control logic time, regardless of the time set in L2-02. The control logic time differs depending on inverter capacity. |

*L2-02 Momentary Power Loss Ridethrough Time**PwrL RideThru t*

| | | | |
|---|---|---|---|
| B | B | B | B |
|---|---|---|---|

Setting Range: 0.0 to 2.0s

Factory Default: Inverter model dependent

Sets the ridethrough time allowed before the inverter trips, after momentary power loss. This setting is activated when *L2-01* is set to “1”. If power is restored within this time, operation restarts automatically. If power is not restored within this time, a fault contact trips, stopping the inverter.

*L2-03 Minimum Baseblock Time**PwrL Baseblock t*

| | | | |
|---|---|---|---|
| B | B | B | B |
|---|---|---|---|

Setting Range: 0.1 to 5.0s

Factory Default: Inverter model dependent

After momentary power loss has occurred, the motor may have residual voltage. This can cause excess current to be drawn by the motor when operation restarts, and can trip the inverter. The minimum baseblock time allows the inverter to wait for this residual voltage to dissipate before restarting. This is only effective when *L2-02* is set to “1” or “2”.

After momentary power loss:

- If the minimum baseblock time (*L2-03*) is greater than the power loss ridethrough time (*L2-02* or control logic time), then operation restarts after the minimum baseblock time elapses.
- If the minimum baseblock time is less than the power loss ridethrough time, then operation restarts after the power loss ridethrough time elapses.

*L2-04 Voltage Recovery Time**PwrL V/f Ramp t*

| | | | |
|---|---|---|---|
| A | A | A | A |
|---|---|---|---|

Setting Range: 0.0 to 5.0s

Factory Default: Inverter model dependent

When operation restarts after momentary power loss, speed search is activated in order to detect the motor speed. After speed search is complete, the time for the output voltage to increase to its previous level (before power loss) is defined by the voltage recovery time.

*L2-05 Undervoltage Detection Level**PUV Det Level*

| | | | |
|---|---|---|---|
| A | A | A | A |
|---|---|---|---|

Setting Range: 150 to 210V (230V class), 300 to 420V (460V class), 431 to 603V (575V class)

Factory Default: 190V (230V class), 380V (460V class), 546V (575V class)

Sets the inverter main circuit DC bus undervoltage level.

When setting this value less than the factory default, it is necessary to install an AC reactor on the input side. The AC reactor reduces peak current input to the inverter and smooths out the DC bus current ripple when operating at low voltages.

*L2-06 Kinetic Energy Braking Frequency Constant**KEB Frequency*

| | | | |
|---|---|---|---|
| A | A | A | A |
|---|---|---|---|

Setting Range: 0 to 100%

Factory Default: 0%

This parameter allows for setting the load inertia ridethrough level, as a percentage of output frequency. This setting is used in conjunction with multi-function contact inputs set for KEB ridethrough (H1-__ = “65” or “66”), after momentary power loss. When the KEB frequency constant is set to “0”, KEB ridethrough functions as normal, to maintain a controlled deceleration rate for the longest time possible, during a momentary power loss (see section H1, Digital Inputs, on page 76 for more details). When the KEB frequency constant is set to any value other than “0”, KEB ridethrough for systems use is enabled.

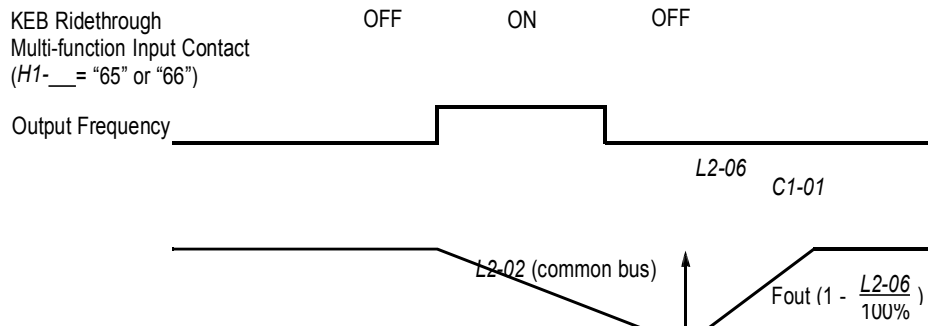

Figure 50 KEB Ridethrough Timing Diagram

In system applications requiring multiple drives with a common DC bus, KEB ride-through functions differently. The inverter decelerates from the output frequency to the KEB frequency level, according to the momentary power loss ridethrough time ($L2-02$). The KEB frequency constant ($L2-06$) is set according to the following equation:

$$\text{KEB Frequency Level} = \text{Output Frequency} \left(1 - \frac{L2-06}{100\%} \right)$$

This method is ideal when helper drives are being used on a film line, and a loss of power might cause a line break. This method will allow synchronized deceleration for all of the common-bus drives, to prevent speed deviation and thus a possible line break. If power is restored within the recovery time ($L2-02$), then the inverter accelerates to the previous frequency reference according to acceleration time 1 ($C1-01$).

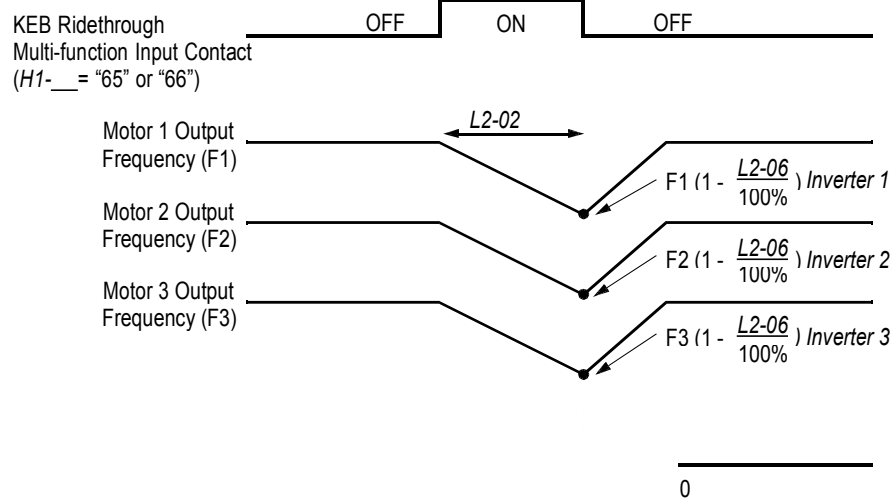

Figure 51 KEB Ridethrough - Common DC Bus Applications

Note: Enabling KEB ridethrough overrides the momentary power loss ride-through selection (L2-01).

L3 Stall Prevention/Current Limit

This function automatically adjusts the output frequency, acceleration and/or deceleration rates in order to continue operation without tripping or “stalling” the inverter.

L3-01 Stall Prevention Selection During Acceleration StallP Accel Sel

| | | | |
|---|---|---|----|
| B | B | B | -- |
|---|---|---|----|

Enables/disables stall prevention/current limit during acceleration.

| Setting | Description |
|---------|--|
| 0 | Stall prevention/current limit during acceleration is disabled. The inverter increases the output frequency at the set acceleration rate. If the acceleration rate is too fast for the load condition, the inverter may trip on overcurrent (OC) or overload (OL). |
| 1 | Stall prevention/current limit during acceleration is enabled (<i>factory default</i>). The acceleration rate is automatically reduced according to motor current to prevent stalling during acceleration. The acceleration time may be longer than the set value (C1-01). |
| 2 | Stall prevention/current limit during acceleration is enabled, with an <i>intelligent</i> acceleration mode. By monitoring motor current, the acceleration rate is automatically adjusted so that acceleration can be completed in the shortest amount of time, regardless of the set acceleration time. |

L3-02 Stall Prevention Level During Acceleration

StallP Accel Lvl

| | | | |
|---|---|---|----|
| B | B | B | -- |
|---|---|---|----|

Setting Range: 0 to 200%
 Factory Default: 150%

The stall prevention/current limit level during acceleration is set as a percentage of inverter rated current. A setting of 200% disables current limit during acceleration. During acceleration, if the output current exceeds this current limit level (L3-02), acceleration stops and frequency is maintained. When the output current decreases below this current limit level (L3-02), acceleration restarts.

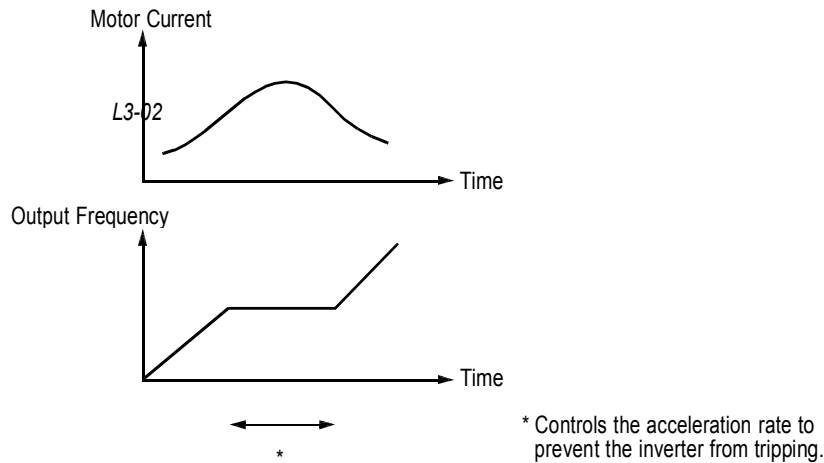

Figure 52 Stall Prevention/Current Limit During Acceleration

L3-03 Stall Prevention Limit (constant output area)

StallP CHP Level

| | | | |
|---|---|---|----|
| A | A | A | -- |
|---|---|---|----|

When a motor is used in the constant output area (constant HP), output frequency max. voltage output frequency (E1-06). In this area, the stall prevention/current limit level during acceleration is automatically reduced for smoother acceleration. This parameter limits the stall prevention/current limit level during acceleration in the constant output area so that it does not decrease unnecessarily. The current limit level during acceleration is changed according to the following equation:

$$\boxed{\text{Current Limit Level During Accel in Constant Output Area}} = \boxed{\text{Current Limit Level During Acceleration (L3-02)}} \times \frac{\text{Max. Voltage Output Frequency (E1-06)}}{\text{Output Frequency}}$$

L3-04 Stall Prevention Selection During Deceleration StallP Decel Sel

| | | | |
|---|---|---|---|
| B | B | B | B |
|---|---|---|---|

If deceleration times are set too short for load conditions, the inverter automatically extends the deceleration time according to the main circuit DC bus voltage level. When using an optional braking resistor for the FST-800 series, set parameter L3-04 to "0".

| Setting | Description |
|---------|--|
| 0 | Stall prevention during deceleration is disabled. An excessively short deceleration time will generate an overvoltage fault (OV), and the inverter will stop. |
| 1 | Stall prevention during deceleration is enabled (<i>factory default</i>). The DC bus voltage level is monitored, and the deceleration rate is automatically extended to prevent an overvoltage condition. This deceleration rate may be longer than the set value (C1-02). |
| 2 | Stall prevention during deceleration is enabled, with an <i>intelligent</i> deceleration mode. By monitoring DC bus voltage, the deceleration rate is automatically adjusted so that deceleration can be completed in the shortest amount of time, regardless of the set deceleration time. |
| 3 | Overvoltage (OV) countermeasure during deceleration (with braking resistor installed). Improves stall prevention during deceleration. Overvoltage (OV) sometimes occurs even under settings 1 or 2 above. The rising of the DC bus voltage is limited during fast deceleration of the motor. This feature allows a faster than normal decel time. <i>Note: When in vector mode setting 3 cannot be used with braking resistor and with stall prevention.</i> |

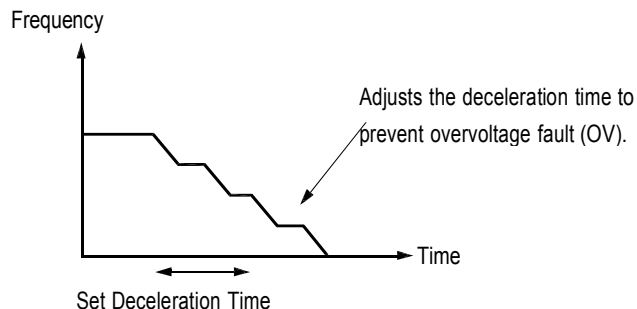

Figure 53 Stall Prevention During Deceleration

Note: Intelligent stall prevention during deceleration (L3-04 = "2") cannot be set in the vector control modes (when A1-02 = "2" or "3").

L3-05 Stall Prevention Selection During Running

StallP Run Sel

| | | | |
|---|---|----|----|
| B | B | -- | -- |
|---|---|----|----|

Sets a function to prevent stalling during an overload condition while running at constant speed.

| Setting | Description |
|---------|--|
| 0 | Stall prevention/current limit during running is disabled. An excessively short deceleration time will generate an overvoltage fault (OV), and the inverter will stop. |
| 1 | Stall prevention/current limit during running is enabled (<i>factory default</i>). When the inverter output current exceeds the current limit level (L3-06) for more than 100ms during speed agree, the output frequency is decreased according to deceleration time 1 (C1-02), and this can prevent stalling. When the load condition is stabilized, the inverter accelerates to the previous frequency. |
| 2 | Stall prevention/current limit during running is enabled as in setting "1", however the output frequency is decreased according to deceleration time 2 (C1-04). |

L3-06 Stall Prevention Level During Running

StallP Run Lvl

| | | | |
|---|---|----|----|
| B | B | -- | -- |
|---|---|----|----|

Setting Range: 30 to 200%

Factory Default: 160%

The stall prevention/current limit level during running is set as a percentage of inverter rated current. A setting of 200% disables current limit during running. During speed agree, if the output current exceeds this current limit level during running, then deceleration starts. When the output current exceeds this current limit level (L3-06), deceleration continues. When the output current decreases below this current limit level (L3-06), acceleration starts, up to the set frequency.

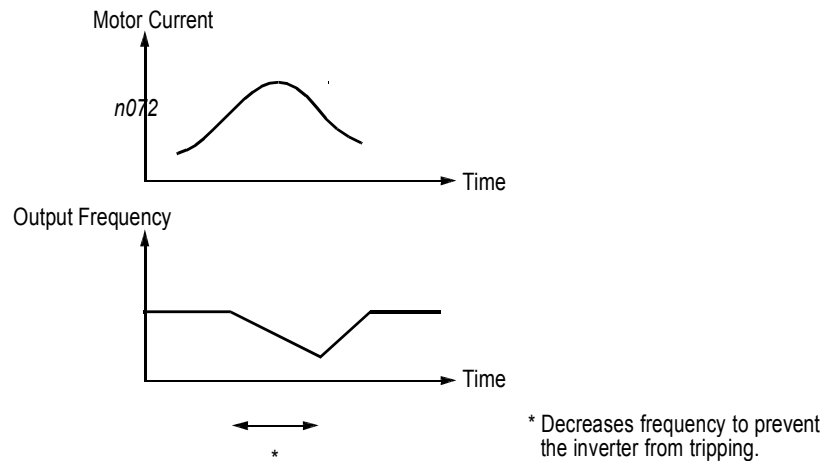

Figure 54 Stall Prevention/Current Limit During Running

L4 Reference Detection

The FST-800 series utilizes three different functions for detecting output frequency:

- When frequency agree is enabled at the multi-function contact outputs ($H2_ = "2"$ or $"13"$), the contact closes whenever the output frequency “agrees” with the frequency reference, plus or minus the speed agree detection width.
- When desired frequency agree is enabled at the multi-function contact outputs ($H2_ = "3"$ or $"14"$), the contact closes whenever the output frequency “agrees” with the speed agree detection level, plus or minus the speed agree detection width.
- When frequency detection is enabled at the multi-function contact outputs ($H2_ = "4"$, $"5"$, $"15"$ or $"16"$), the contact closes whenever the output frequency is less than or more than the speed agree detection level, depending on which detection is selected.

Refer to section **H2, Digital Outputs** on page 88, for more detailed information on setting these functions.

| | | | | | | |
|--------------|---|------------------------|---|---|---|---|
| <i>L4-01</i> | <i>Speed Agree Detection Level (without sign)</i> | <i>Spd Agree Level</i> | B | B | B | B |
| | Setting Range: 0.0 to 400.0Hz | | | | | |
| | Factory Default: 0.0Hz | | | | | |

Sets the detection level for the desired frequency agree 1 and frequency detection 1 and 2 functions. The set detection level is effective during both FWD and REV operation.

| | | | | | | |
|--------------|------------------------------------|------------------------|---|---|---|---|
| <i>L4-02</i> | <i>Speed Agree Detection Width</i> | <i>Spd Agree Width</i> | B | B | B | B |
| | Setting Range: 0.0 to 20.0Hz | | | | | |
| | Factory Default: 2.0Hz | | | | | |

Sets the detection width for frequency and desired frequency agree 1 and frequency detection 1 and 2 functions.

| | | | | | | |
|--------------|--|------------------------|---|---|---|---|
| <i>L4-03</i> | <i>Speed Agree Detection Level (with sign)</i> | <i>Spd Agree Lvl+-</i> | A | A | A | A |
| | Setting Range: 0.0 to ± 400.0 Hz | | | | | |
| | Factory Default: 0.0Hz | | | | | |

Sets the detection level for the desired frequency agree 2 and frequency detection 3 and 4 functions. The set detection level is effective during either FWD or REV operation, depending on the set detection level (positive value for FWD operation, negative value for REV operation).

| | | | | | | |
|--------------|------------------------------------|--------------------------|---|---|---|---|
| <i>L4-04</i> | <i>Speed Agree Detection Width</i> | <i>Spd Agree Width+-</i> | A | A | A | A |
| | Setting Range: 0.0 to 20.0Hz | | | | | |
| | Factory Default: 2.0Hz | | | | | |

Sets the detection width for frequency and desired frequency agree 2 and frequency detection 3 and 4 functions.

*L4-05 Operation When Frequency Reference Loss**Ref Loss Sel*

| | | | |
|---|---|---|---|
| A | A | A | A |
|---|---|---|---|

Selects operation when the frequency reference from the control circuit terminal is reduced by 90% within 400ms.

| Setting | Description |
|---------|---|
| 0 | Stop (factory default). |
| 1 | Run at 80% of the previous frequency reference. |

L5 Automatic Restart

After a fault occurs, the inverter and its fault detection circuit can be reset. The automatic restart function allows the inverter to continue operation after certain faults.

*L5-01 Number of Automatic Restart Attempts**Num of Restarts*

| | | | |
|---|---|---|---|
| B | B | B | B |
|---|---|---|---|

Setting Range: 0 to 10

Factory Default: 0

Sets the number of automatic restart attempts. Setting to "0" disables this function.

Automatic Restart Operation

- When a fault is detected, the inverter output shuts OFF for the minimum baseblock time (*L2-03*). The digital operator displays the fault while the inverter output is shut OFF.
- While the minimum baseblock time elapses, the fault is reset automatically and speed search starts from the previous output frequency before the fault occurred.
- When the total number of faults exceeds the number of automatic restart attempts, the faults are *not* reset automatically and the inverter output remains OFF. At this time, a fault contact output is activated.

The inverter can be set to automatically restart after the following faults occur:

- Overcurrent (OC)
- Overvoltage (OV)
- Undervoltage PUV (UV1)
- Ground fault (GF)
- Regenerative transistor fault (rr)

However, automatic restart is not available for the following faults:

- Control circuit undervoltage (UV2)
- MC answer-back fault (UV3)
- Load short-circuit (SC)
- Heatsink overheat (OH)
- Run command fault (EF)
- Overspeed (OS)
- Excessive speed deviation (DEV)
- PG disconnection (PGO)
- Parameter setting error (OPR)
- Communication error (CE)
- External fault (EF3 to EF8)

The number of restart attempts is reset to 0 when:

- A fault does not occur for more than 10 minutes after restart.
- A fault reset command is input from the control circuit terminal or the digital operator.
- Power is cycled.

L5-02 Automatic Restart Operation Selection

Restart Sel

| | | | |
|---|---|---|---|
| B | B | B | B |
|---|---|---|---|

Selects whether a fault contact output is activated during automatic restart.

| Setting | Description |
|---------|----------------------------------|
| 0 | No fault relay (factory default) |
| 1 | Fault relay active |

L6 Torque Detection

The overtorque detection circuit activates when the motor load causes the motor current (or torque during vector control) to exceed the overtorque detection level (L6-02). When an overtorque condition is detected, alarm signals are sent to multi-function output terminals 9, 25 and 26.

To output an overtorque detection signal, select torque detection 1 at either of the multi-function contact outputs (H2-__ = "B" or "17"). Refer to section H2, Digital Outputs on page 88, for more details.

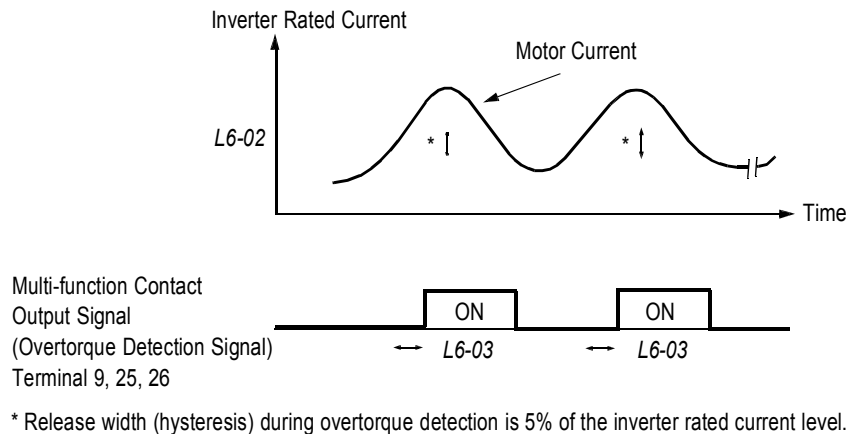

Figure 55 Overtorque Characteristics Timing Diagram

L6-01 Overtorque Detection 1 Selection

Torq Det 1 Sel

| | | | |
|---|---|---|---|
| B | B | B | B |
|---|---|---|---|

Activates overtorque detection, and selects whether detection generates an alarm or a fault.

| Setting | Description |
|---------|--|
| 0 | Overtorque detection is disabled (factory default). |
| 1 | Overtorque detection is enabled whenever at the speed agree level (when inverter is not accelerating or decelerating). Continue running after detection (OL3 alarm). |
| 2 | Overtorque detection is enabled always. Continue running after detection (OL3 alarm). |
| 3 | Overtorque detection is enabled whenever at the speed agree level. Coast to a stop after detection (OL3 fault). |
| 4 | Overtorque detection is enabled always. Coast to a stop after detection (OL3 fault). |

L6-01 Notes:

1. To detect torque during acceleration or deceleration, set to "2" or "4".
2. To continue operation after overtorque detection, set to "1" or "2". During detection, the digital operator displays an "OL3" alarm (blinking).
3. To stop the inverter after an overtorque detection fault, set to "3" or "4". During detection, the digital operator displays an "OL3" fault.

L6-02 Overtorque Detection 1 Level**Torq Det 1 Lvl**

| | | | |
|---|---|---|---|
| B | B | B | B |
|---|---|---|---|

Setting Range: 0 to 300%
 Factory Default: 150%

Sets the overtorque detection level as a percentage of inverter rated current, during V/f control, and motor rated torque, during vector control.

L6-03 Overtorque Detection 1 Time**Torq Det 1 Time**

| | | | |
|---|---|---|---|
| B | B | B | B |
|---|---|---|---|

Setting Range: 0.0 to 10.0s
 Factory Default: 0.1s

The overtorque detection delay time inserts a delay, between the time motor current (or torque) exceeds the overtorque detection level (*L6-02*) and when the overtorque detection function is enabled. The digital operator then displays “OL3”.

L6-04 Overtorque Detection 2 Selection**Torq Det 2 Sel**

| | | | |
|---|---|---|---|
| A | A | A | A |
|---|---|---|---|

Activates overtorque detection 2, and selects whether detection generates an alarm or a fault.

| Setting | Description |
|---------|--|
| 0 | Overtorque detection is disabled (<i>factory default</i>). |
| 1 | Overtorque detection is enabled whenever at the speed agree level (when inverter is not accelerating or decelerating). Continue running after detection (OL4 alarm). |
| 2 | Overtorque detection is enabled always. Continue running after detection (OL4 alarm). |
| 3 | Overtorque detection is enabled whenever at the speed agree level. Coast to a stop after detection (OL4 fault). |
| 4 | Overtorque detection is enabled always. Coast to a stop after detection (OL4 fault). |

Overtorque detection 2 functions the same as overtorque detection 1 (*L6-01*), except that “OL4” is displayed on the digital operator instead. This function is used when two types of detection are output to the multi-function output terminals.

L6-05 Overtorque Detection 2 Level**Torq Det 2 Lvl**

| | | | |
|---|---|---|---|
| A | A | A | A |
|---|---|---|---|

Setting Range: 0 to 300%
 Factory Default: 150%

Sets the second overtorque detection level as a percentage of inverter rated current, during V/f control, and motor rated torque, during vector control.

L6-06 Overtorque Detection 2 Time**Torq Det 2 Time**

| | | | |
|---|---|---|---|
| A | A | A | A |
|---|---|---|---|

Setting Range: 0.0 to 10.0s
 Factory Default: 0.1s

The overtorque detection 2 delay time inserts a delay, between the time motor current (or torque) exceeds the overtorque detection level (*L6-05*) and when the second overtorque detection function is enabled. The digital operator then displays “OL3”.

L7 Torque Limit

The torque limit function limits the amount of motor torque in all four quadrants of vector control operation:

- Forward Motoring
- Reverse Motoring
- Forward Regenerating
- Reverse Regenerating

Torque limit is activated in both the speed and torque control modes.

L7-01 Forward Torque Limit

Torq Limit Fwd

| | | | |
|---|----|---|---|
| - | -- | B | B |
|---|----|---|---|

Setting Range: 0 to 300%
 Factory Default: 200%

Sets the motoring side torque limit value during FWD run.

L7-02 Reverse Torque Limit

Torq Limit Rev

| | | | |
|---|----|---|---|
| - | -- | B | B |
|---|----|---|---|

Setting Range: 0 to 300%
 Factory Default: 200%

Sets the motoring side torque limit value during REV run.

L7-03 Regenerative Forward Torque Limit

Torq Lmt Fwd Rgn

| | | | |
|---|----|---|---|
| - | -- | B | B |
|---|----|---|---|

Setting Range: 0 to 300%
 Factory Default: 200%

Sets the regenerating side torque limit value during FWD run.

L7-04 Regenerative Reverse Torque Limit

Torq Lmt Rev Rgn

| | | | |
|---|----|---|---|
| - | -- | B | B |
|---|----|---|---|

Setting Range: 0 to 300%
 Factory Default: 200%

Sets the regenerating side torque limit value during REV run.

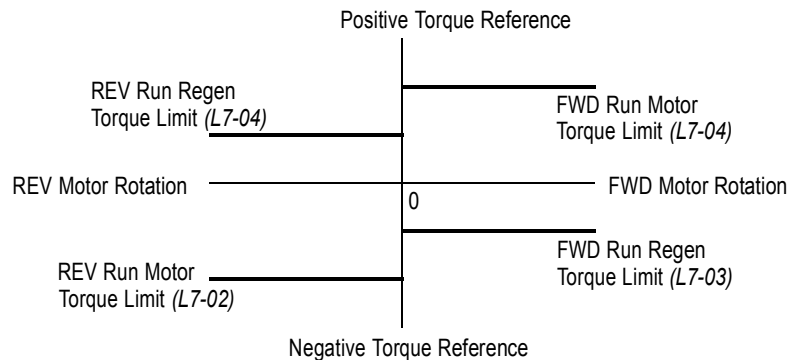

Figure 56 Torque Limit - 4 Quadrant Operation

L8 Hardware Protection

The FST-800 series comes equipped with a number of built-in functions designed to protect the inverter and its components from damage. This section describes the set-up of these functions.

L8-01 Protection Selection for Internal DB Resistor *DB Resistor Prot*

| | | | |
|---|---|---|---|
| B | B | B | B |
|---|---|---|---|

When a Anyhertz dynamic braking resistor is used, protection against overheating is enabled with this function. The duty cycle of the braking resistor is monitored in software so that it does not exceed 3%.

| Setting | Description |
|----------|--|
| 0 | DB resistor overheating protection is not provided (<i>factory default</i>). |
| 1 | DB resistor overheating protection is provided. |

If the duty cycle exceeds 3%, a DB overheating fault (RH) occurs, and the inverter coasts to stop.

L8-02 OH Pre-Alarm Level *OH Pre-Alarm Lvl*

| | | | |
|---|---|---|---|
| A | A | A | A |
|---|---|---|---|

Setting Range: 0 to 100 C
 Factory Default: 100 C

Sets the heatsink temperature level for protection against overheating (OH).

L8-03 Stopping Method Selection After OH Pre-Alarm *OH Pre-Alarm Sel*

| | | | |
|---|---|---|---|
| A | A | A | A |
|---|---|---|---|

Selects the stopping method when heatsink overheating is detected.

| Setting | Description |
|----------|---|
| 0 | Ramp to stop according to C1-02 setting. |
| 1 | Coast to stop |
| 2 | Ramp to stop according to C1-09 setting (fast-stop). |
| 3 | Operation continues, alarm only (<i>factory default</i>). |

L8-05 Input Phase Loss Protection *Ph Loss In Sel*

| | | | |
|---|---|---|---|
| A | A | A | A |
|---|---|---|---|

The input phase loss detection circuit monitors the DC bus current ripple and activates when the one of the input phases are lost. The detection circuit calculates the maximum and minimum values of the DC bus voltage in one second intervals, and compares the difference (V) between these values with an internal detection level. If V reaches or exceeds the detection level, then after 0.5 second, input phase loss is detected; a PF fault occurs, and the motor coasts to stop.

| Setting | Description |
|----------|---|
| 0 | Input phase loss protection is disabled (<i>factory default</i>). |
| 1 | Input phase loss protection is enabled. |

Input phase loss detection is disabled in the following cases:

- A Stop command is input.
- Magnetic Contactor (MC) shuts OFF.
CPU A/D converter fault (CPF5).
- During deceleration.
- Output current 30% of Inverter rated current.

L8-07 Output Phase Loss Protection

Ph Loss Out Sel

| | | | |
|---|---|---|---|
| A | A | A | A |
|---|---|---|---|

The output phase loss detection circuit monitors the DCCT and activates when one of the output phases are lost. The detection circuit calculates the RMS current value (I_{RMS}) for each of the phases and compares it with an internal output detection level. If I_{RMS} decreases to or below the detection level for 10 seconds, an output phase loss (LF) fault occurs, and the motor coasts to stop.

| Setting | Description |
|---------|--|
| 0 | Output phase loss protection is disabled (<i>factory default</i>). |
| 1 | Output phase loss protection is enabled. |

L8-10 Ground Fault Protection

Ground Fault Sel

| | | | |
|---|---|---|---|
| A | A | A | A |
|---|---|---|---|

The ground fault detection circuit monitors the output current and activates when one of the output phases is connected to ground.
A ground fault will occur when the inverter output grounding current has exceeded 50% of the inverter rated current.

When a ground fault condition occurs, the following fault code will be displayed: "GF Ground Fault".

| Setting | Description |
|---------|---|
| 0 | Disabled - Ground fault protection is disabled |
| 1 | Enabled - Ground fault protection is enabled. (<i>factory default</i>). |

*L8-17 IGBT Protection at Low Speed**Prtct@L-Spd*

| | | | |
|---|---|---|---|
| A | A | A | - |
|---|---|---|---|

This parameter assists in protecting the IGBT from overheating of the transistor junction when the output current is high and the output frequency is low. The settings are as follows:

| Setting | Description |
|---------|--|
| 0 | Conventional Method (No change in carrier), inverter relies on L8-19 protection (same as 1042 software). |
| 1 | <i>Lower fc - When output current is greater than 100%, and output frequency is less than or equal to 10Hz, the carrier frequency is automatically decreased to the L8-18 setting (between 8 and 2 kHz depending on model). The carrier will automatically return to the normal value after the load is reduced. (factory default)</i> |
| 2 | Short term OL2 - OL occurs in 2 seconds when at low output frequencies (6Hz or less) and in hard current limit. |
| 3 | I-Limit=150% - Current limit is 150% of inverter rated current. The IGBT junction temperature should be below any critical level provided the output current is less than 150%. <1110> |

*L8-19 OL2 Characteristics at Low speed <1110>**OL2 Chara@L-Spd*

| | | | |
|---|---|---|---|
| A | A | A | A |
|---|---|---|---|

This parameter allows the selection of normal or fast OL2 protection below 6 or 10 Hz. It is recommended that this parameter be enabled at all times. In some instances fast OL2 protection (L8-19=1) may not be desired, such as when operating in flux vector at zero speed. If L8-19 is set to 0 (disabled) L8-17 must be set to 1,2, or 3.

| Setting | Description |
|---------|--|
| 0 | Disabled -OL2 protection is disabled at low speed. This OL2 protection is the same at high speed and low speed. <i>(factory default)</i> . |
| 1 | Enabled - A current limiting function is performed at low speed, the inverter OL2 protection responds quickly at 6 Hz or less. |

Caution: When disabling OL2 protection, (L8-19=0) verify that the motor current will not go beyond the current limit level when operating below 10 Hz. Or set the carrier frequency equal to or less than 2 kHz.

O Operator Parameters

O1 Monitor Selection

O1-01 Monitor Selection

User Monitor Sel

| | | | |
|---|---|---|---|
| A | A | A | A |
|---|---|---|---|

The top level in the operation menu allows the viewing of four monitor variables. These are F_{ref} , F_{out} , I_{out} , and a user-selected monitor. This function can replace the output voltage monitor with another monitor in the operation mode. Choose one of the monitors *U1-04* to *U1-39* in this parameter.

| Setting | Descriptio |
|----------|--|
| 4 | Control method |
| 5 | Motor speed |
| 6 | Output voltage (<i>factory default</i>) |
| 7 | DC bus voltage |
| 8 | Output power |
| 9 | Torque reference (internal) |
| 10 | Input terminal status |
| 11 | Output terminal status |
| 12 | Internal control status 1 |
| 13 | Elapsed time |
| 14 | FLASH ID number |
| 15 | Terminal 13 input voltage level |
| 16 | Terminal 14 input voltage or current level |
| 17 | Terminal 16 input voltage level |
| 18 | Motor secondary current (Iq) |
| 19 | Motor excitation current (Id) |
| 20 | SFS output frequency |
| 21 | ASR input |
| 22 | ASR output |
| 23 | Speed deviation |
| 24 | PID feedback |
| 25 | DI-16H reference |
| 26 | Voltage reference (Vq output) |
| 27 | Voltage reference (Vd output) |
| 28 | CPU ID number |
| 32 | ACR (q) Output |
| 33 | ACR (d) Output |
| 34 | OPE Detected |
| 35 | Zero Servo Pulse |
| 36 | PID Deviation |
| 37 | PID Output Monitor |
| 38 | PID Setpoint |

O1-02 Monitor Selection After Power-up

Power-On Monitor

| | | | |
|---|---|---|---|
| B | B | B | B |
|---|---|---|---|

Selects the monitor to be displayed on the digital operator immediately after the power supply is turned ON.

| Setting | Description |
|---------|--|
| 1 | Displays frequency reference (<i>factory default</i>). |
| 2 | Displays output frequency. |
| 3 | Displays output current. |
| 4 | Displays the monitor set in <i>O1-01</i> . |

O1-03 Scale for Setting and Monitoring Frequency

Display Scaling

| | | | |
|---|---|---|---|
| B | B | B | B |
|---|---|---|---|

Units for parameters and monitors related to frequency can be scaled as shown below.

| Setting | Description |
|---|---|
| 00000 | Unit: 0.01Hz (<i>factory default</i>) |
| 00001 | Unit: 0.01% |
| 00002 to 00039 | Unit: rpm (0 to 3999) |
| 00040 to 03999 (user-selected units) | <p>Digits: <u>5th</u> <u>4th</u> <u>3rd</u> <u>2nd</u> <u>1st</u> 0 0 0 0 0</p> <p>The 1st thru 4th digits determine the set value at 100% output frequency. Decimal point position is set by the 5th digit as follows: 5th digit = 0: displayed as UUUU 5th digit = 1: displayed as 000.0 5th digit = 2: displayed as 00.00 5th digit = 3: displayed as 0.000</p> <p><i>Example 1</i> If 100% output frequency is equal to 200.0 units: Set <i>O1-03</i> = "12000"; 100% of this reference is displayed as 200.0 and 60% of this reference is displayed as 120.0.</p> <p><i>Example 2</i> If 100% output frequency is equal to 65.00: Set <i>O1-03</i> = "26500"; 60% of this reference is displayed as 39.00.</p> |

01-04 Display Units for Speed-Related Parameters *Display Units*

| | | | |
|----|----|----|---|
| -- | -- | -- | B |
|----|----|----|---|

Sets the display units for parameters and monitors related to frequency, in the flux vector control mode.

| Setting | Description |
|---------|--|
| 0 | Displays frequency in Hz (<i>factory default</i>). |
| 1 | Displays frequency in rpm. |

01-05 Parameter Selection*Address Display*

| | | | |
|---|---|---|---|
| A | A | A | A |
|---|---|---|---|

Selects how the parameter addresses are displayed on the digital operator.

| Setting | Description |
|---------|---|
| 0 | Displays parameter number (<i>factory default</i>). |
| 1 | Displays MODBUS address. |

02 Key Selections**02-01 Local/Remote Key***Local/Remote Key*

| | | | |
|---|---|---|---|
| B | B | B | B |
|---|---|---|---|

Enables/disables the digital operator LOCAL/REMOTE key.

| Setting | Description |
|---------|--|
| 0 | Local/Remote key is disabled. |
| 1 | Local/Remote key is enabled (<i>factory default</i>). Depressing the Local/Remote key switches operation commands between the digital operator and the settings of B1-01 and B1-02. |

02-02 STOP Key During External Terminal Operation *Oper STOP Key*

| | | | |
|---|---|---|---|
| B | B | B | B |
|---|---|---|---|

Enables/disables the digital operator STOP key, during operation from the external terminals and during serial communication.

| Setting | Description |
|---------|--|
| 0 | The digital operator STOP key is disabled when Run command does <i>not</i> come from the digital operator. |
| 1 | The digital operator STOP key is always enabled (<i>factory default</i>). The STOP key is enabled even during external terminal operation and serial communication. |

O2-03 User-Defined Default Value Setting

User Defaults

| | | | |
|---|---|---|---|
| B | B | B | B |
|---|---|---|---|

Parameters set by user can be stored in the inverter as user default values.

| Setting | Description |
|---------|--|
| 0 | No change (<i>factory default</i>) |
| 1 | Sets user-specified values as defaults. Each parameter's set values are stored as user defaults. Even if the values are changed after this parameter is set, user defaults can be restored by setting A1-03 = "1110" (user initialization). Up to 50 changed values can be stored. |
| 2 | Clears user defaults. |

O2-04 Inverter Model Selection

Inverter Model #

| | | | |
|---|---|---|---|
| A | A | A | A |
|---|---|---|---|

Setting Range: 23P7 to 2075, 43P7 to 4300

Factory Default: Inverter model dependent

Sets the inverter capacity, according to model number. Control parameters with defaults specific to the inverter capacity are set automatically (i.e. carrier frequency, motor data, etc.). This parameter does *not* need changing, unless the control board is replaced.

O2-05 Digital Operator M.O.P. Mode Selection

Operator M.O.P.

| | | | |
|---|---|---|---|
| A | A | A | A |
|---|---|---|---|

Selects whether the ENTER key is used when the frequency reference is set by the digital operator. The digital operator can simulate a motor operated potentiometer (M.O.P.) by setting this parameter.

| Setting | Description |
|---------|--|
| 0 | The digital operator M.O.P. mode is disabled (<i>factory default</i>). The inverter accepts the frequency reference command when the ENTER key is depressed. |
| 1 | The digital operator M.O.P. mode is enabled. The inverter accepts the frequency reference command as soon as changes are made with the arrow keys, <i>without</i> the ENTER key being depressed. |

*O2-06 Digital Operator Disconnection Detection**Oper Detection*

| | | | |
|---|---|---|---|
| A | A | A | A |
|---|---|---|---|

If the digital operator is disconnected from the inverter, this parameter selects whether the inverter detects this condition.

| Setting | Description |
|---------|---|
| 0 | Detection is disabled. Operation continues (<i>factory default</i>). |
| 1 | Detection is enabled. When the inverter detects that the digital operator has been disconnected while running, the inverter coasts to stop and the error message "OPR Operator Disconnected" is displayed on the digital operator, after it is connected again. |

This function can only be activated when the run command comes from the digital operator.

*O2-07 Operation Time Setting**Elapsed Time Set*

| | | | |
|---|---|---|---|
| A | A | A | A |
|---|---|---|---|

Setting Range: 0 to 65535 Hours
 Factory Default: 0 Hours

Sets the initial value for the cumulative operation time. Operation time starts accumulating from the set value. This is very useful for preventive maintenance purposes.

*O2-08 Cumulative Operation Time Selection**Elapsed Time Run*

| | | | |
|---|---|---|---|
| A | A | A | A |
|---|---|---|---|

Defines the operation time that accumulates in the timer.

| Setting | Description |
|---------|---|
| 0 | Power-On time is the accumulated time (<i>factory default</i>). The timer counts the time while the inverter power supply is turned ON as operation time. |
| 1 | Running time is the accumulated time. The timer counts the time while the inverter is running as operation time. |

*O2-09 Initialization Mode Selection**Init Mode Sel*

| | | | |
|---|---|---|---|
| A | A | A | A |
|---|---|---|---|

Sets factory defaults to worldwide specifications.

| Setting | Description |
|---------|--|
| 0 | Japanese specifications |
| 1 | American specifications (<i>factory default</i>) |
| 2 | European specifications |
| 3 | OMRON specifications |

After changing this setting, reinitialize the inverter in parameter A1-03. This initialization affects market-driven parameter settings (motor-related parameters, carrier frequency, inverter rated current, etc.)

Main Menu: Auto-Tuning <ENTER>

Adaptation to most all 3 phase induction motors manufactured worldwide is possible with the Anyhertz automatic tuning function. Available in both open loop vector and flux vector control modes, the inverter asks the user for minimal motor information, then guides the user through a quick, simple tuning process. Below is the motor data required for automatic tuning in the quick-start mode:

| | | | | | |
|------------------------------|--|--|--|---|---|
| <i>Motor Rated Voltage</i> | Sets motor rated voltage in VAC. | | | Q | Q |
| <i>Motor Rated Current</i> | Sets motor rated current in A. | | | Q | Q |
| <i>Motor Rated Frequency</i> | Sets motor rated frequency in Hz. | | | Q | Q |
| <i>Motor Rated Speed</i> | Sets motor rated speed in rpm. | | | Q | Q |
| <i>Number of Motor Poles</i> | Sets the number of motor poles. | | | Q | Q |
| <i>Motor Selection</i> | Chooses connected motor as 1st or 2nd motor. | | | Q | Q |

After scrolling through tuning parameters using the key, depress the Run key to begin auto-tuning. During tuning, "Tune Proceeding" flashes on the digital operator display. After complete, "Tune Successful" is displayed.

Note: If the Stop key is depressed during tuning, auto-tuning is interrupted and the motor coasts to stop. The data changed during tuning returns to its original values.

After tuning is complete, depress the Menu key to exit the auto-tuning mode.

1. Parameter List

| Function | Parameter No. | Name (Digital Operator Display) | Setting Range | Setting Unit | Factory Setting | Remarks (Digital Operator Display) | Change during Operation: o: Enabled x: Disabled | Parameter Access Level | | | | User Setting | |
|-----------------|----------------|---|---|---------------------------|-----------------|--|---|------------------------|-----------|------------------|-------------|--------------|--|
| | | | | | | | | V/f | V/f w/ PG | Open Loop Vector | Flux Vector | | |
| Initialize | Initialization | A1-00 | Language Selection (Select Language) | 0.1 | 1 | 1 (Note1) | 0: English 1: Traditional Chinese 2: Simplified Chinese 3: German 4: French 5: Russian 6: Spanish | o | Q | Q | Q | Q | |
| | | A1-01 | Access Level (Access Level) | 0~4 | 1 | 2 | 0: Operation Only 1: User Level (Note 5) 2: Quick-Start [Q] 3: Basic Level [B] 4: Advanced Level [A] | o | Q | Q | Q | Q | |
| | | A1-02 | Control Method Selection (Control method) | 0~3 | 1 | 0 (Note1) | 0: V/F Control 1: V/F w/PG Fdbk 2: Open Loop Vector 3: Flux Vector | x | Q | Q | Q | Q | |
| | | A1-03 | Initialize (Init Parameters) | 0 1110 2220 3330 | N/A | 0 | 0 : No Initialize 1110: User Initialize (Note 7) 2220: 2-Wire Initialize 3330: 3-Wire Initialize | x | Q | Q | Q | Q | |
| | A1-04 | Password 1 * (Enter Password) | 0000~9999 | 1 | 0000 | Password protection for: A1-01 Access Level A1-02 Control Method A1-03 Initialization A2-01 to A2-32 User Parameters | x | Q | Q | Q | Q | | |
| User Parameters | A2-01 ~A2-32 | User Setting Parameters (Function A2) | — | — | — | User Parameter 1 to User Parameter 32 | x | A | A | A | A | | |
| Note 1 | | Not initialized. (Domestic standard specifications: A1-01 = 1, A1-02 = 2) | | | | | | | | | | | |
| Note 2 | | Setting range is only 0 and 1 when the control method is set to flux vector control (A1-02 = 3) | | | | | | | | | | | |
| Note 5 | | Selection "1: User Level" is only available after selecting setting 4: Advanced Level and then entering a user parameter in A2-01. Note 7 | | | | | | | | | | | |
| Note 7 | | Setting 1110: User Initialize is only available after setting Parameter No. 02-03 to 1. | | | | | | | | | | | |

| Function | Parameter No. | Name (Digital Operator Display) | Setting Range | Setting Unit | Factory Setting | Remarks (Digital Operator Display) | Change during Operation o: Enabled x: Disabled | Parameter Access Level | | | | User Setting |
|--|---------------|--|----------------|--------------|-----------------|---|--|------------------------|-----------|------------------|-------------|--------------|
| | | | | | | | | V/f | V/f w/ PG | Open Loop Vector | Flux Vector | |
| Group B Application Function b1 Sequence | B1-01 | Reference Selection (Reference Source) | 0 ~ 4 | 1 | 1 | 0: (Operator) 1: (Terminals) 2: Communication (Serial Com) 3: (Option PCB) 4: (EWS) Reference from CP-717 <1110>(Note 8) | x | Q | Q | Q | Q | |
| | B1-02 | Operation Method Selection (Run Source) | 0 ~ 4 | 1 | 1 | 0: (Operator) 1: (Terminals) 2: Communication(Serial Com) 3: (Option PCB) 4: (EWS) Run from CP-717 <1110> (Note 8) | x | Q | Q | Q | Q | |
| | B1-03 | Stopping Method Selection (Stopping Method) | 0 ~ 3 (Note 2) | 1 | 0 | 0: (Ramp to Stop) 1: (Coast to Stop) 2: DC injection to stop (DCInj to Stop) 3: Coast to stop with timer (Coast w/Timer) | x | Q | Q | Q | Q | |
| | B1-04 | Reverse Operation Prohibit (Reverse Oper) | 0, 1 | 1 | 0 | 0: (Reverse Enabled) 1: (Reverse Disabled) | x | B | B | B | B | |
| | B1-05 | Operation Selection for Setting of E1-09 or less (Zero-Speed) | 0 ~ 3 | 1 | 0 | 0: Run at frequency reference (Run at Freq Ref) 1: (STOP) 2: Run at minimum frequency (RUN at Min Freq) 3: (RUN at Zero RPM) | x | - | - | - | A | |
| | B1-06 | Digital Input Scan Time (Cntl Input Scans) | 0, 1 | 1 | 1 | 0: (2 mS - 2 Scans) 1: (5 mS - 2 Scans) | x | A | A | A | A | |
| | B1-07 | Operation selection after switching to remote mode (LOC/REM RUN Sel) | 0, 1 | 1 | 0 | 0: Cycle external run (Cycle Extern RUN) 1: Accept external run (Accept Extern RUN) | x | A | A | A | A | |
| | B1-08 <1110> | Run command acceptance while being programmed (RUN CMD at | 0, 1 | 1 | 0 | 0: Disabled 1: Enabled | x | A | A | A | A | |
| <p>Note 2 Setting range is only 0 and 1 when the control method is set to flux vector control (A1-02 = 3)</p> <p>Note 8 (Tentative) Setting parameter B1-01 or B1-02 to 4 allows reference and/or run source from CP-717 when either CP-916 or CP-216 option cards are installed.</p> <p>Note 9 Drive can be switched between local and remote mode while continuing to run. When switching from remote to local the last remote speed command will be set as the local speed for a bumpless transition.</p> | | | | | | | | | | | | |

| Function | Parameter No. | Name (Digital Operator Display) | Setting Range | Setting Unit | Factory Setting | Remarks (Digital Operator Display) | Change during Operation o: Enabled x: Disabled | Parameter Access Level | | | | User Setting | |
|---------------------|--------------------------------|---------------------------------|--|--------------|-----------------|------------------------------------|--|------------------------|-----------|------------------|-------------|--------------|--|
| | | | | | | | | V/f | V/f w/ PG | Open Loop Vector | Flux Vector | | |
| Group b Application | Function b2 DC Injection Brake | B2-01 | DC Injection Braking Starting Frequency (DCInj Start Freq) | 0.0~10.0 | 0.1Hz | 0.5 | — | x | B | B | B | B | |
| | | B2-02 | DC Injection Current (DCInj Current) | 0~100 | 1% | 50 | — | x | B | B | B | - | |
| | | B2-03 | DC Injection Time at Start (DCInj Time @Start) | 0.00~10.00 | 0.01s | 0.00 | — | x | B | B | B | B | |
| | | B2-04 | DC Injection Braking Time at Stop (DCInj Time @Stop) | 0.00~10.00 | 0.01s | 0.50 * | * When 02-09 = 1 (American), the setting is 0.00s. <24> | x | B | B | B | B | |
| | | B2-08 <1110> | Magnetic Flux Compensation Capacity (FieldComp) | 0~500 | 1% | 0 | 100% is no-load current value at Min. frequency (E1-09) | x | - | - | A | A | |
| | Speed Search | B3-01 | Speed Search Selection at Start (SpdSrCh at Start) | 0,1 | 1 | 0* | 0: Disabled 1: Enabled * Factory setting defaults to 0: Disabled except when (A1-02=1) (V/F w/PG Fdbk) or 3 (Flux Vector). | x | A | A | A | A | |
| | | B3-02 | Speed Search Operation Current (SpdSrCh Current) | 0~200 | 1% | 150* | * Factory setting defaults to 150 when A1-02=0 (V/F Control). When A1-02=2 (Open Loop Vector), the default is 100. | x | A | - | A | - | |
| | | B3-03 | Speed Search Deceleration Time (SpdSrCh Dec Time) | 0.1~10.0 | 0.1s | 2.0 | — | x | A | - | A | - | |
| | Delay Timers | B4-01 | Timer Function On-delay Time (Delay-ON Timer) | 0.0~300.0 | 0.1s | 0.0 | — | x | A | A | A | A | |
| | | B4-02 | Timer Function Off-delay Time (Delay-OFF Timer) | 0.0~300.0 | 0.1s | 0.0 | — | x | A | A | A | A | |
| Group b Application | Function b5 PID Control | B5-01 | PID Control Mode Selection (PID Mode) | 0 ~ 4 | 1 | 0 | 0: (Disabled) 1: (Enabled D=Fdbk) 2: Enabled D = Feed-Forward (Enabled D=Fdfwd) 3: Reference = Frequency Reference + PID Output (Fref+PID D=Fdbk) 4: Reference = Frequency Reference + PID Output D is feed-forward (Fref+PID D=Fdfwd) | x | A | A | A | A | |

| Function | Parameter No. | Name (Digital Operator Display) | Setting Range | Setting Unit | Factory Setting | Remarks (Digital Operator Display) | Change during Operation o: Enabled x: Disabled | Parameter Access Level | | | | User Setting | |
|------------------------|---|---------------------------------|---|------------------------|---|------------------------------------|--|------------------------|---|------------------|-------------|--------------|---|
| | | | | | | | | V/f | V/f w/ PG | Open Loop Vector | Flux Vector | | |
| Group b Application | Function b5 PID Control | B5-02 | Proportional Gain (P) (PID Gain) | 0.00~25.00 | 0.01 | 1.00 | — | o | A | A | A | A | |
| | | B5-03 | Integral (I) Time (PID I Time) | 0.0~360.0 | 0.1s | 1.0 | — | o | A | A | A | A | |
| | | B5-04 | Integral (I) Limit (PID I Limit) | 0.0~100.0 | 0.1% | 100 | — | o | A | A | A | A | |
| | | B5-05 | Derivative (D) Time (PID D Time) | 0.00~10.00 | 0.01s | 0.00 | — | o | A | A | A | A | |
| | | B5-06 | PID Limit (PID Limit) | 0.00~100.0 | 0.1% | 100.0 | — | o | A | A | A | A | |
| | | B5-07 | PID Offset Adjustment (PID Offset) | -100.0~+100.0 | 0.1% | 0.0 | — | o | A | A | A | A | |
| | | B5-08 | PID Primary Delay Time (PID Delay Time) | 0.00~10.00 | 0.01s | 0.00 | — | o | A | A | A | A | |
| | | B5-09 <1110> | PID Output Selection (Output Level Sel) | 0, 1 | 1 | 0 | 0: PID Forward Output [X 1] (Normal Character) 1: PID Reverse Output [X-1] (Rev Character) | x | A | A | A | A | |
| | | B5-10 <1110> | PID Output Gain (Output Gain) | 0.0 ~ 25.0 | .1 | 1.0 | — | x | A | A | A | A | |
| | | B5-11 <1110> | PID Output Reverse Selection (Output Rev Sel) | 0, 1 | 1 | 0 | 0: When PID output is negative, motor direction is not changed, PID output is limited to 0. (0 limit) 1: When PID output is negative, motor reverses direction. (Reverse) | x | A | A | A | A | |
| | | PID Control | | B5-12 <1110> | PID Feedback Reference Missing Detection Selection (Fb Los Det Sel) | 0~2 | 1 | 0 | 0: PID feedback missing detection disabled. (Disabled) 1: PID feedback missing detection enabled. (Alarm) Operation continues after detection, "Fb" alarm is displayed. 2: PID feedback missing detection enabled. (Fault) Inverter output is shut off after detection, "Fbl" is displayed. | x | A | A | A |
| B5-13 <1110> | PID Feedback Reference Missing Detection Level (Fb los Det Lvl) | | | 0~100 | 1% | 0 | — | x | A | A | A | A | |
| B5-14 <1110> | PID Feedback Reference Missing Detection Time (Fb los Det Time) | | | 0.0~25.5 | 0.1s | 1.0 | — | x | A | A | A | A | |

| Function | Parameter No. | Name (Digital Operator Display) | Setting Range | Setting Unit | Factory Setting | Remarks (Digital Operator Display) | Change during Operation o: Enabled x: Disabled | Parameter Access Level | | | | User Setting | |
|---------------------|----------------------------|---------------------------------|--|--------------|-----------------|------------------------------------|--|--|-----------|------------------|-------------|--------------|--|
| | | | | | | | | V/f | V/f w/ PG | Open Loop Vector | Flux Vector | | |
| Group b Application | Function b6 Reference Hold | B6-01 | Dwell Frequency at Start (Dwell Ref @Start) | 0.0~400.0 | 0.1Hz | 0.0 | — | x | A | A | A | A | |
| | | B6-02 | Dwell Time at Start (Dwell Time @ Start) | 0.0~10.0 | 0.1s | 0.0 | — | x | A | A | A | A | |
| | | B6-03 | Dwell Frequency at Stop (Dwell Ref @ Stop) | 0.0~400.0 | 0.1Hz | 0.0 | — | x | A | A | A | A | |
| | | B6-04 | Dwell Time at Stop (Dwell Time @ Stop) | 0.0~10.0 | 0.1s | 0.0 | — | x | A | A | A | A | |
| | Function b7 Droop Control | B7-01 | Droop Control Gain (Droop Quantity) | 0.0~100.0 | 0.1% | 0.0 | — | o | - | - | - | A | |
| | | B7-02 | Droop Control Delay Time (Droop Delay Time) | 0.03~2.00 | 0.01s | 0.05 | — | o | - | - | - | A | |
| | Function b8 Energy Saving | B8-01 | Energy-saving Gain (Energy Save Gain) | 0~100 | 1% | 80 | — | x | A | A | - | - | |
| | | B8-02 | Energy-saving Frequency (Energy Save Freq) | 0.0~400.0 | 0.1Hz | 0.0 | — | x | A | A | - | - | |
| | | B8-03 <1110 | Energy -saving Mode Selection | 0, 1 | 1 | 0 | 0: (Disabled) 1: (Enabled) | x | - | - | F (A) Note | F (A) Note | |
| | | B8-04 <1110 > | Energy-saving Control Gain (Energy Save Gain) | 0.0~10.0 | 0.1 | 0.7* | *When control mode A1-02 = 3, default factory setting becomes1.0 | o | - | - | F (A) Note | F (A) Note | |
| | | B8-05 <1110 > | Energy-saving Control Time Constant (Energy Save F .T) | 0.00~10.00 | 0.01s | 0.50* | *When control mode A1-02 = 3, default factory setting becomes.01 | o | - | - | F (A) Note | F (A) Note | |
| | Zero Servo | B9-01 | Zero-servo gain (Zero Servo Gain) | 0~100 | 1 | 5 | — | x | - | - | - | A | |
| | | B9-02 | Zero-servo Completion Width (Zero Servo Count) | 0~16383 | 1 | 10 | — | x | - | - | - | A | |
| | | | | | | | | Note: USA (02x09=1) and EUR. (02x09=2) are Advanced, others are Factory setting. | | | | | |

| Function | Parameter No. | Name (Digital Operator Display) | Setting Range | Setting Unit | Factory Setting | Remarks (Digital Operator Display) | Change during Operation o: Enabled x: Disabled | Parameter Access Level | | | | User Setting | |
|-------------------------------------|---------------------------|---|--|---|-----------------------------------|---|--|------------------------|-----------|------------------|-------------|--------------|--|
| | | | | | | | | V/f | V/f w/ PG | Open Loop Vector | Flux Vector | | |
| Group C Tuning | Function C1 Accel / Decel | C1-01 | Acceleration Time 1 (Accel Time 1) | Depends on C1-10 0.00~600.00 or 0.0 ~ 6000.0 | Depends on C1-10 0.01s or 0.1s | 10.0 | — | o | Q | Q | Q | Q | |
| | | C1-02 | Deceleration Time 1 (Decel Time 1) | | | 10.0 | — | o | Q | Q | Q | Q | |
| | | C1-03 | Acceleration Time 2 (Accel Time 2) | | | 10.0 | — | o | B | B | B | B | |
| | | C1-04 | Deceleration Time 2 (Decel Time 2) | | | 10.0 | — | o | B | B | B | B | |
| | | C1-05 | Acceleration Time 3 (Accel Time 3) | | | 10.0 | — | x | A | A | A | A | |
| | | C1-06 | Deceleration Time 3 (Decel Time 3) | | | 10.0 | — | x | A | A | A | A | |
| | | C1-07 | Acceleration Time 4 (Accel Time 4) | | | 10.0 | — | x | A | A | A | A | |
| | | C1-08 | Deceleration Time 4 (Decel Time 4) | | | 10.0 | — | x | A | A | A | A | |
| | | C1-09 | Emergency Stop Time (Fast Stop Time) | | | 10.0 | — | x | B | B | B | B | |
| | | C1-10 | Accel/Decel Time Set Unit (Acc/Dec Units) | 0.1 | 1 | 1 | 0: Set unit of accel/decel time is 0.01s. (0.01 Seconds) 1: Set unit of accel/decel time is 0.1s. (0.1 Seconds) | x | A | A | A | A | |
| | | C1-11 | Accel/Decel Time Switching Frequency (Acc/Dec SW Freq) | 0.0~400.0 | 0.1Hz | 0.0 | — | x | A | A | A | A | |
| Function C2 S-Curve Acc/Dec | C2-01 | S-Curve Characteristic Time at Acceleration Start | 0.00~2.50 | 0.01s | 0.20 | — | x | A | A | A | A | | |
| | C2-02 | S-Curve Characteristic Time at Acceleration End | 0.00~2.50 | 0.01s | 0.20 | — | x | A | A | A | A | | |
| | C2-03 | S-Curve Characteristic Time at Deceleration Start | 0.00~2.50 | 0.01s | 0.20 | — | x | A | A | A | A | | |
| Function C3 Motor Slip Compensation | C3-01 | Slip Compensation Gain (Slip Comp Gain) | 0.0~2.5 | 0.1 | 1.0* | * Default factory setting is 0.0 when A1-02=0 [V/F mode]. When A1-02=2 [Open Loop Vector] or 3 [Flux Vector] default factory setting is 1.0 | o | B | - | B | B | | |
| | C3-02 | Slip Compensation Primary Delay Time (Slip Comp Time) | 0~10000 | 1 ms | 200* | * Default factory setting is 2000ms when A1-02=0 [V/F mode]. When A1-02=2 [Open Loop Vector] default factory setting is 200ms. | x | A | - | A | - | | |
| | C3-03 | Slip Compensation Limit (Slip Comp Limt) | 0~250 | 1% | 200 | — | x | A | - | A | - | | |

| Function | Parameter No. | Name (Digital Operator Display) | Setting Range | Setting Unit | Factory Setting | Remarks (Digital Operator Display) | Change during Operation o: Enabled x: Disabled | Parameter Access Level | | | | User Setting |
|--|------------------------|---|---------------|--------------|-----------------|---|--|------------------------|-----------|------------------|-------------|--------------|
| | | | | | | | | V/f | V/f w/ PG | Open Loop Vector | Flux Vector | |
| Group C Tuning Function C3 Motor Slip Compensation | C3-04 | Slip Compensation Selection during Regeneration (Slip Comp Regen) | 0, 1 | 1 | 0 | 0 : Disabled 1 : Enabled | x | A | - | A | - | |
| | C3-05 <1110> | Flux Calculation Method (Flux Select) | 0, 1 | 1 | 0 | 0 : Magnetic flux is calculated by output frequency after compensation. (Slip Included) 1 : Magnetic flux is calculated by output frequency before compensation. (Slip | x | - | - | A | - | |
| | C3-06 <1110> | Output Voltage Limit Operation Selection | 0, 1 | 1 | 0 | 0 : Disabled (Note 10) 1 : Enabled (Note 11) | x | - | - | A | A | |
| <p>Note 10 When this parameter is "0" slip compensation will be disabled when the motor is operating above its base speed. The motor voltage will not be reduced above base speed.</p> <p>Note 11 Open Loop Vector: When this parameter is set to "1" the motor voltage will be reduced slightly when the motor is operating above 90% base speed. Slip Compensation is enabled. Speed control accuracy is improved. This may prevent speed instabilities due to motor voltage saturation. This setting may improve speed regulation however motor torque/amp will be reduced by up to 10% due to motor voltage reduction above base speed. Flux Vector: Torque linearity is improved.</p> | | | | | | | | | | | | |

| Function | Parameter No. | Name (Digital Operator Display) | Setting Range | Setting Unit | Factory Setting | Remarks (Digital Operator Display) | Change during Operation o: Enabled x: Disabled | Parameter Access Level | | | | User Setting | |
|----------------|---------------------------------|---------------------------------|--|--------------|-----------------|------------------------------------|--|------------------------|-----------|------------------|-------------|--------------|--|
| | | | | | | | | V/f | V/f w/ PG | Open Loop Vector | Flux Vector | | |
| Group C Tuning | Function C4 Torque Compensation | C4-01 | Torque Compensation Gain (Torq Comp Gain) | 0.00~2.50 | 0.01 | 1.00 | — | o | B | B | B | - | |
| | | C4-02 | Torque Compensation Time (Torq Comp Time) | 0~10000 | 1 ms | 20* | * When A1-02=2 [Open Loop Vector] factory default setting is 20 ms. When A1-02=1 or 3 [V/ F or V/ F w/PG] factory default setting is 200 ms. | x | A | A | A | - | |
| | | C4-03 <1110> | Forward Torque Compensation Value @ Start (F TorqCmp @start) | 0.0~200.0 | 0.1% | 0.0 | Functions only when starting a motor. Torque reference and motor flux can be ramped up quickly to improve speed response during start. A setting of 0.0 disables this feature. | x | - | - | A | - | |
| | | C4-04 <1110> | Reverse Torque Compensation Value @ Start. (R TorqCmp @ start) | 200.0~0.0 | 0.1% | 0.0 | Functions only when starting a motor. Torque reference and motor flux can be ramped up quickly to improve speed response during start. A setting of 0.0 disables this feature. | x | - | - | A | - | |
| | | C4-05 <1110> | Torque Compensation Time Constant (TorqCmp Delay T) | 0~200 | 1ms | 10 | When 0~4ms is set, it is operated without filter. Functions with C4-03 and C4-04. | x | - | - | A | - | |
| | Function C5 ASR Tuning | C5-01 | ASR Proportional (P) Gain 1 (ASR P Gain 1) | 0.00~300.00 | 0.01 | 20.00* | When A1-02=1 [V/f w/PG] factory default setting is .20. When A1-02=3 factory default setting is 20.00. | o | - | B | - | B | |
| | | C5-02 | ASR Integral (I) Time 1 (ASR 1 Time 1) | 0.000~10.000 | 0.001s | 0.500* | When A1-02=1 [V/f w/PG] factory default setting is .200. When A1-02=3 factory default setting is .500 | o | - | B | - | B | |
| | | C5-03 | ASR Proportional (P) Gain 2 (ASR P Gain 2) | 0.00~300.00 | 0.01 | 20.00* | When A1-02=1 [V/f w/PG] factory default setting is .02. When A1-02=3 factory default setting is 20.00. | o | - | B | - | B | |
| | | C5-04 | ASR Integral (I) Time 2 (ASR 1 Time 2) | 0.000~10.000 | 0.001s | 0.500* | When A1-02=1 [V/f w/PG] factory default setting is .050. When A1-02=3 factory default setting is .500. | o | - | B | - | B | |
| | | C5-05 | ASR Limit (ASR Limt) | 0.0~20.0 | 0.1% | 5.0 | — | x | - | A | - | - | |
| | | C5-06 | ASR Primary Delay Time (ASR Delay Time) | 0.000~0.500 | 0.001s | 0.004 | — | x | - | - | - | A | |
| | | C5-07 | ASR Switching Frequency (ASR Gain SW) | 0.0~400.0 | 0.1Hz | 0.0 | — | x | - | - | - | A | |
| | | C5-08 | ASR Integral Limit (ASR I Limit) | 0~400 | 1 | 400% | — | x | - | - | - | A | |

| Function | Parameter No. | Name (Digital Operator Display) | Setting Range | Setting Unit | Factory Setting | Remarks (Digital Operator Display) | Change during Operation o: Enabled x: Disabled | Parameter Access Level | | | | User Setting | |
|----------------|--------------------------------|---------------------------------|--|--------------|-----------------|------------------------------------|---|------------------------|-----------|------------------|-------------|--------------|--|
| | | | | | | | | V/f | V/f w/ PG | Open Loop Vector | Flux Vector | | |
| Group C Tuning | Function C6 Carrier Frequency | C6-01 | Carrier Frequency Upper Limit (Carrier Freq Max) | 0.4~15.0** | 0.1 kHz | 15.0** | When control mode is vector control (A1-02=2, 3), the setting range of C6-01 and C6-02 is 2.0 ~15.0. ** Setting range and factory setting differ depending on inverter capacity. | x | B | B | B | B | |
| | | C6-02 | Carrier Frequency Lower Limit (Carrier Freq Min) | 0.4~15.0 | 0.1 kHz | 15.0** | | x | A | A | - | - | |
| | | C6-03 | Carrier Frequency Proportional Gain (Carrier Freq Gain) | 00~99* | 1 | 00** | | x | A | A | - | - | |
| | Function C7 Hunting Prevention | C7-01 | Hunting Prevention Selection (Hunt Prev Select) | 0, 1 | 1 | 1 | 0: Disabled 1: Enabled | x | A | A | - | - | |
| | | C7-02 | Hunting Prevention Gain (Hunt Prev Gain) | 0.00~2.50 | 0.01 | 1.00 | — | x | A | A | - | - | |
| Group C Tuning | Function C8 Factory Tuning | C8-08 | AFR Gain (AFR Gain) | 0.00~10.00 | 0.01 | 1.00 | — | x | - | - | A | - | |
| | | C8-09 | AFR Time Constant (AFR Time) | 0~2000 | 1 ms | 50 | — | x | - | - | A | - | |
| | | C8-30 <1110> | Carrier Frequency Selection during Auto-tuning (Carrier in tune) | 0~2 | 1 | 0 | 0: Carrier frequency is 2 kHz. 1: Carrier frequency depends on C6-01. 2: Carrier frequency is 5 kHz. (185~300 kW: 2.5 kHz) | x | - | - | A | A | |

| Function | Parameter No. | Name (Digital Operator Display) | Setting Range | Setting Unit | Factory Setting | Remarks (Digital Operator Display) | Change during Operation o: Enabled x: Disabled | Parameter Access Level | | | | User Setting | |
|-------------------|------------------------------|---------------------------------------|---|--------------|-----------------|------------------------------------|--|------------------------|-----------|------------------|-------------|--------------|--|
| | | | | | | | | V/f | V/f w/ PG | Open Loop Vector | Flux Vector | | |
| Group d Reference | Function d1 Preset Reference | D1-01 | Frequency Reference 1 (Reference 1) | 0.00~400.00 | 0.01Hz | 0.00 | — | o | Q | Q | Q | Q | |
| | | D1-02 | Frequency Reference 2 (Reference 2) | 0.00~400.00 | 0.01Hz | 0.00 | — | o | Q | Q | Q | Q | |
| | | D1-03 | Frequency Reference 3 (Reference 3) | 0.00~400.00 | 0.01Hz | 0.00 | — | o | Q | Q | Q | Q | |
| | | D1-04 | Frequency Reference 4 (Reference 4) | 0.00~400.00 | 0.01Hz | 0.00 | — | o | Q | Q | Q | Q | |
| | | D1-05 | Frequency Reference 5 (Reference 5) | 0.00~400.00 | 0.01Hz | 0.00 | — | o | B | B | B | B | |
| | | D1-06 | Frequency Reference 6 (Reference 6) | 0.00~400.00 | 0.01Hz | 0.00 | — | o | B | B | B | B | |
| | | D1-07 | Frequency Reference 7 (Reference 7) | 0.00~400.00 | 0.01Hz | 0.00 | — | o | B | B | B | B | |
| | | D1-08 | Frequency Reference 8 (Reference 8) | 0.00~400.00 | 0.01Hz | 0.00 | — | o | B | B | B | B | |
| | | D1-09 | Jog Frequency Reference (Jog Reference) | 0.00~400.00 | 0.01Hz | 6.00 | — | o | Q | Q | Q | Q | |
| | Function d2 Reference Limits | D2-01 | Frequency Reference Upper Limit (Ref Upper Limit) | 0.0~110.0 | 0.1% | 100.0 | — | x | B | B | B | B | |
| | | D2-02 | Frequency Reference Lower Limit (Ref Lower Limit) | 0.0~109.0 | 0.1% | 0.0 | — | x | B | B | B | B | |
| | Function d3 Jump Frequencies | D3-01 | Jump Frequency 1 (Jump Freq 1) | 0.0~400.0 | 0.1Hz | 0.0 | — | x | B | B | B | B | |
| | | D3-02 | Jump Frequency 2 (Jump Freq 2) | 0.0~400.0 | 0.1Hz | 0.0 | — | x | B | B | B | B | |
| D3-03 | | Jump Frequency 3 (Jump Freq 3) | 0.0~400.0 | 0.1Hz | 0.0 | — | x | B | B | B | B | | |
| D3-04 | | Jump Frequency Width (Jump Bandwidth) | 0.0~20.0 | 0.1Hz | 1.0 | — | x | B | B | B | B | | |

| Function | Parameter No. | Name (Digital Operator Display) | Setting Range | Setting Unit | Factory Setting | Remarks (Digital Operator Display) | Change during Operation o: Enabled x: Disabled | Parameter Access Level | | | | User Setting |
|-------------------|----------------------------|--|---------------|--------------|-----------------|--|--|------------------------|-----------|------------------|-------------|--------------|
| | | | | | | | | V/f | V/f w/ PG | Open Loop Vector | Flux Vector | |
| Group d Reference | Function d4 Sequence | | | | | | | | | | | |
| | D4-01 | Frequency Reference Hold Function Selection (MOP Ref Memory) | 0, 1 | 1 | 0 | 0: (Disabled) No hold frequency is memo- rized. 1: (Enabled) Hold frequency is memo- rized. | x | A | A | A | A | |
| | D4-02 | ±Speed Limits (Trim Control Lvl) | 0~100 | 1% | 25* | *When 02-09=1 [USA], the unit is 10%. <24> | x | A | A | A | A | |
| | Function d5 Torque Control | | | | | | | | | | | |
| | D5-01 | Torque Control Selection (Torq Control Sel) | 0, 1 | 1 | 0 | 0: (Speed Control) 1: (Torque Control) | x | - | - | - | A | |
| | D5-02 | Torque Reference Delay Time (Torque Ref Filter) | 0~1000 | 1 ms | 0 | — | x | - | - | - | A | |
| | D5-03 | Speed Limit Selection (Speed Limit Sel) | 1, 2 | 1 | 1 | 1: (Analog Input) terminal 13, 14 2: (Program Setting) | x | - | - | - | A | |
| | D5-04 | Speed Limit (Speed Lmt Value) | -120 ~ +120 | 1% | 0 | — | x | - | - | - | A | |
| | D5-05 | Speed Limit Bias (Speed Lmt Bias) | 0~120 | 1% | 10 | — | x | - | - | - | A | |
| | D5-06 | Speed/torque Control Switching Timer (Ref Hold Time) | 0~1000 | 1 ms | 0 | — | x | - | - | - | A | |

| Function | Parameter No. | Name (Digital Operator Display) | Setting Range | Setting Unit | Factory Setting | Remarks (Digital Operator Display) | Change during Operation o: Enabled x: Disabled | Parameter Access Level | | | | User Setting |
|---|---------------|---|---------------------|--------------|------------------|---|--|------------------------|-----------|------------------|-------------|--------------|
| | | | | | | | | V/f | V/f w/ PG | Open Loop Vector | Flux Vector | |
| Group E Motor Function E1 V/F Pattern | E1-01 | Input Voltage Setting (Input Voltage) | 155~255 (Note 13) | 1 V | 200 (Note 13) | *When 02-09=1 [USA], the value is 1.15 times of Japanese spec., which is 230/200 | x | Q | Q | Q | Q | |
| | E1-02 | Motor Selection (Motor Selection) | 0, 1, 2 | 1 | 0 | 0: (Std Fan-Cooled) 1: (Std Blower-Cooled) 2: (Vector Motor) <1110> | x | Q | Q | Q | Q | |
| | E1-03 | V/f Pattern Selection (V/F Selection) | 00~0F | 1 | 0F | V/f pattern selection 0: 50Hz 1: 60Hz Saturation 2: 50Hz Saturation 3: 72Hz 4: 50Hz Variable Torque 1 5: 50Hz Variable Torque 1 6: 60Hz Variable Torque 1 7: 60Hz Variable Torque 2 8: 50Hz High Starting Torque 1 9: 50Hz High Starting Torque 2 A: 60Hz High Starting Torque 1 B: 60Hz High Starting Torque 2 C: 90Hz D:120Hz E:180Hz F: User-defined V/f pattern | x | Q | Q | Q | Q | |
| | E1-04 | Max. Output Frequency (Max Frequency) | 40.0~400.0 | 0.1Hz | 60.0* (Note 13) | *Factory setting differs depending on the inverter capacity 02-04. When 02-09=2 [EUR.], the value is 50.0Hz. | x | Q | Q | Q | Q | |
| | E1-05 | Max. Voltage (Max Voltage) | 0.0~255.0 (Note 13) | 0.1 V | 200.0 (Note 13)* | *Factory setting differs depending on the inverter capacity (02-04). When 02-09=1 (USA), the value is 1.15 times of Japanese spec., which is 230/200 | x | Q | Q | Q | Q | |
| Note 13: This value is for the 200V class. For 400V class, the value is twice that of 200V class. For 575V class, then modify the values by 575/200 | | | | | | | | | | | | |
| Group E Motor Torque Control | E1-06 | Max. Voltage Frequency (Base Frequency) | 0.0~400.0 | 0.1Hz | 60.0* (Note 13) | *Factory setting differs depending on the inverter capacity (02-04). When 02-09=2 (EUR.), the value is 50.0Hz. | x | Q | Q | Q | Q | |
| | E1-07 | Mid. Output Frequency (Mid Frequency A) | 0.0~400.0 | 0.1Hz | 3.0* (Note 13) | *Factory setting differs depending on the inverter capacity (02-04). When 02-09=2 (EUR.), A1-02=0, and E1-03=0F, the value is 5/6 times that of Japan spec.[for a V/F pattern with a 50Hz base frequency] | x | Q | Q | A | F | |

| Function | Parameter No. | Name (Digital Operator Display) | Setting Range | Setting Unit | Factory Setting | Remarks (Digital Operator Display) | Change during Operation o: Enabled x: Disabled | Parameter Access Level | | | | User Setting |
|---------------------------------|---------------|---|----------------------|--------------|------------------|---|--|------------------------|-----------|------------------|-------------|--------------|
| | | | | | | | | V/f | V/f w/ PG | Open Loop Vector | Flux Vector | |
| Group E Motor Torque Control | E1-08 | Mid. Output Frequency Voltage (Mid Voltage A) | 0.00~255.0 (Note 13) | 0.1 V | 11.0 (Note 13)* | *Factory setting differs depending on the inverter capacity (02-04). When 02-09=1 (USA), the value is 1.15 times of Japanese spec., which is 230/200 . | x | Q | Q | A | F | |
| | E1-09 | Min. Output Frequency (Min Frequency) | 0.0~400.0 | 0.1Hz | 0.5* (Note 13) | *Factory setting differs depending on the inverter capacity (02-04). When 02-09=2 (EUR.), A1-02=0, and E1-03=OF, the value is 5~6 times of Japan. | x | Q | Q | Q | A | |
| | E1-10 | Min. Output Frequency Voltage (Min Voltage) | 0.0~255.0 (Note 13) | 0.1V | 2.0 (Note 13)* | *Factory setting differs depending on the inverter capacity (02-04). When 02-09=1 (USA), the value is 1.15 times of Japanese spec., which is 230/200. | x | Q | Q | A | F | |
| | E1-11 | Mid. Output Frequency 2 (Mid Frequency B) | 0.0~400.0 | 0.1Hz | 0.0 | — | x | A | A | A | A | |
| | E1-12 | Mid. Output Frequency Voltage 2 (Mid Voltage B) | 0.0~255.0 (Note 13)* | 0.1V | 0.0 | *When 02-09=1 (USA), the value is 1.15 times of Japanese spec., which is 230/200. | x | A | A | A | A | |
| | E1-13 | Base Voltage (Base Voltage) | 0.0~255.0 (Note 13) | 0.1V | 200.0 (Note 13)* | *When 02-09=1 (USA), the value is 1.15 times of Japanese spec., which is 230/200. | x | A | A | Q | Q | |

Note 13: This value is for the 200V class. For 400V class, the value is twice that of 200V class. For 575V class, then modify the values by 575/200

| | | | | | | | | | | | | |
|--|-------|---|--------------|---------|---------|---|---|---|---|---|---|--|
| Group E Motor Function E2 Motor Setup | E2-00 | Motor Rated (Motor Rated) | — | — | — | * When inverter capacity is 7.5 kW or less, min. setting unit becomes 0.01 A. ** Factory setting differs depending on inverter capacity (02-04). | x | - | - | - | - | |
| | E2-01 | Motor Rated Current (Motor Rated FLA) | 0.1~1500.0 | 0.1A* | 1.9** | | x | Q | Q | Q | Q | |
| | E2-02 | Motor Rated Slip (Motor Rated Slip) | 0.00~20.00 | 0.01Hz | 2.90** | | x | A | A | Q | Q | |
| | E2-03 | Motor No-load Current (No-Load Current) | 0.00~1500.0 | 0.01A* | 1.20** | | x | A | A | Q | Q | |
| | E2-04 | Number of Motor Poles (Number of Poles) | 2~48 | 1 pole | 4 | | x | - | Q | - | Q | |
| | E2-05 | Motor Line-to-line Resistance (Term Resistance) | 0.000~65.000 | 0.001 W | 9.842** | | x | A | A | A | A | |

| Function | Parameter No. | Name (Digital Operator Display) | Setting Range | Setting Unit | Factory Setting | Remarks (Digital Operator Display) | Change during Operation o: Enabled x: Disabled | Parameter Access Level | | | | User Setting |
|---|---------------|--|---------------------|--------------|-----------------|---|--|------------------------|-------------|------------------|-------------|--------------|
| | | | | | | | | V/f | V/f w/ PG | Open Loop Vector | Flux Vector | |
| Group E: Motor Function E2: Motor Setup | E2-06 | Motor Leak Inductance (Leak Inductance) | 0.0~30.0 | 0.1% | 18.2** | | x | - | - | A | A | |
| | E2-07 | Motor Iron-core Saturation Coefficient 1 (Saturation Comp 1) | 0.00~0.50 | 0.01 | 0.50 | — | x | - | - | A | A | |
| | E2-08 | Motor Iron-core Saturation Coefficient 2 (Saturation Comp 2) | 0.00~0.75 | 0.01 | 0.75 | — | x | - | - | A | A | |
| | E2-09 | Motor Mechanical Loss (Mechanical Loss) | 0.0~10.0 | 0.1% | 0.0 | — | x | - | - | - | A | |
| | E2-10 | Motor Iron Loss of Torque Compensation (Tcomp Iron Loss) | 0~65535 | 1W | 14 | Access level is changed from F to A. <1110> | x | A | A | - | - | |
| Group E: Motor Function E3: Control Method Function E4: V/F Pattern 2 | E3-01 | Motor 2 Control Method Selection (Control Method) | 0~3 | 1 | 2 | 0: (V/F Control) 1: (V/F w/PG Fdbk) 2: (Open Loop Vector) 3: (Flux Vector) | x | A | A | A | A | |
| | E4-01 | Motor 2 Max. Output Frequency (Max Frequency) | 40.0~400.0 | 0.1Hz | 60.0 | — | x | A (Note 14) | A (Note 14) | A (Note 14) | A (Note 14) | |
| | E4-02 | Motor 2 Max. Voltage (Max Voltage) | 0.0~255.0 (Note 13) | 0.1V | 200.0 (Note 13) | — | x | A (Note 14) | A (Note 14) | A (Note 14) | A (Note 14) | |
| | E4-03 | Motor 2 Max. Voltage Frequency (Base Frequency) | 0.0~400.0 | 0.1Hz | 60.0 | — | x | A (Note 14) | A (Note 14) | A (Note 14) | A (Note 14) | |
| | E4-04 | Motor 2 Mid. Output Frequency 1 (Mid Frequency) | 0.00~400.0 | 0.1Hz | 3.0* | * Factory setting differs depending on the control method [E3-01] | x | A (Note 14) | A (Note 14) | A (Note 14) | F (Note 14) | |
| | E4-05 | Motor 2 Mid. Output Voltage 1 (Mid Voltage) | 0.0~255.0 (Note 13) | 0.1V | 11.0 (Note 13)* | * Factory setting differs depending on the control method [E3-01] | x | A (Note 14) | A (Note 14) | A (Note 14) | F (Note 14) | |
| | E4-06 | Motor 2 Min. Output Frequency (Min Frequency) | 0.0~400.0 | 0.1Hz | 0.5* | * Factory setting differs depending on the control method [E3-01] | x | A (Note 14) | A (Note 14) | A (Note 14) | A (Note 14) | |
| | E4-07 | Motor 2 Min. Output Voltage (Min Voltage) | 0.0~255.0 (Note 13) | 0.1V | 2.0* (Note13) | * Factory setting differs depending on the control method [E3-01] | x | A (Note 14) | A (Note 14) | A (Note 14) | F (Note 14) | |

Note 13: This value is for the 200V class. For 400V class, the value is twice that of 200V class. For 575V class, then modify the values by 575/200
 Note 14: Control mode is determined by E3-01.

| Function | Parameter No. | Name (Digital Operator Display) | Setting Range | Setting Unit | Factory Setting | Remarks (Digital Operator Display) | Change during Operation o: Enabled x: Disabled | Parameter Access Level | | | | User Setting |
|--|---------------|---|---------------|--------------|-----------------|---|--|------------------------|-------------|------------------|-------------|--------------|
| | | | | | | | | V/f | V/f w/ PG | Open Loop Vector | Flux Vector | |
| Group E Motor Function E5 Motor Setup 2 | E5-01 | Motor 2 Rated Current (Motor Rated FLA) | 0.00~1500.0 | 0.1A* | 1.9** | * Setting unit is 0.01A for models of 7.5 kW or less. ** Factory setting differs depending on inverter capacity (02-04). | x | A (Note 14) | A (Note 14) | A (Note 14) | A (Note 14) | |
| | E5-02 | Motor 2 Rated Slip (Motor Rated Slip) | 0.00~20.00 | 0.01Hz | 2.90** | | x | A (Note 14) | A (Note 14) | A (Note 14) | A (Note 14) | |
| | E5-03 | Motor 2 No-load Current (No-Load Current) | 0.00~1500.0 | 0.01A* | 1.20** | | x | A (Note 14) | A (Note 14) | A (Note 14) | A (Note 14) | |
| | E5-04 | Motor 2 Number of poles (Motor 2 # Poles) | 2~48 | 1 pole | 4 | | x | - (Note 14) | A (Note 14) | - (Note 14) | A (Note 14) | |
| | E5-05 | Motor 2 Line-to-line Resistor (Motor 2 term Ohms) | 0.000~65.000 | 0.001 W | 9.842** | | x | A (Note 14) | A (Note 14) | A (Note 14) | A (Note 14) | |
| | E5-06 | Motor 2 Leak Inductance (Motor 2 Leak) | 0.0~30.0 | 0.1% | 18.2** | | x | A (Note 14) | - (Note 41) | A (Note 14) | A (Note 14) | |

Note 13: This value is for the 200V class. For 400V class, the value is twice that of 200V class. For 575V class, modify the values by 575/200

Note 14: Control mode is determined by E3-01.

| | | | | | | | | | | | | |
|--|-------|---|---------|----|------|--|---|---|---|---|---|--|
| Group F Options * Function F1 PG Option Setup | F1-01 | PG Constant (PG Pulses/Rev) | 0~60000 | 1 | 600* | *When 02-09=1 (USA), 2 (EUR.), factory setting is 1024 | x | - | Q | - | Q | |
| | F1-02 | Operation Selection at PG Open Circuit (PG Fdbk Loss) | 0~3 | 1 | 1 | 0: (Ramp to Stop) 1: (Coast to Stop) 2: (Fast-Stop) 3: (Alarm Only) | x | - | B | - | B | |
| | F1-03 | Operation Selection at Overspeed (PG Overspeed Sel) | 0~3 | 1 | 1 | 0: (Ramp to Stop) 1: (Coast to Stop) 2: (Fast-Stop) 3: (Alarm Only) | x | - | B | - | B | |
| | F1-04 | Operation Selection at Deviation (PG Deviation Sel) | 0~3 | 1 | 3 | 0: (Ramp to Stop) 1: (Coast to Stop) 2: (Fast-Stop) 3: (Alarm Only) | x | - | B | - | B | |
| | F1-05 | PG Rotation (PG Rotation Sel) | 0, 1 | 1 | 0 | 0: Counter-clockwise (Fwd = C.C.W.) 1: Clockwise (Fwd = C.W.) | x | - | B | - | B | |
| | F1-06 | PG Division Rate PG --Pulse monitor (PG Output Ratio) | 1~132 | 1 | 1 | Effective only when control circuit board PG-B2 is used. | x | - | B | - | B | |
| | F1-07 | Integral Value during Accel/decel Enable/disable (PG Ramp PI/I Sel) | 0, 1 | 1 | 0 | 0: (Disabled) 1: (Enabled) | x | - | B | - | - | |
| | F1-08 | Overspeed Detection Level (PG Overspd) | 0~120 | 1% | 115 | — | x | - | A | - | A | |

* When access level is BASIC (A1-03), constant is not displayed unless the option is connected.

| Function | Parameter No. | Name (Digital Operator Display) | Setting Range | Setting Unit | Factory Setting | Remarks (Digital Operator Display) | Change during Operation o: Enabled x: Disabled | Parameter Access Level | | | | User Setting | |
|---|-----------------------------|---------------------------------|--|--------------|-----------------|------------------------------------|--|------------------------|-----------|------------------|-------------|--------------|--|
| | | | | | | | | V/f | V/f w/ PG | Open Loop Vector | Flux Vector | | |
| Group F Options* | Function F1 PG Option Setup | F1-09 | Overspeed Detection Delay Time (PG Overspd Time) | 0.0~2.0 | 0.1s | 0.0* | * When A1-02=1 [V/f w/PG] factory setting is 1.0. When A1-02=3 [Flux Vector] factory setting is 0.0. | x | - | A | - | A | |
| | | F1-10 | Excessive Speed Deviation Detection Level (PG Deviate Level) | 0~50 | 1% | 10 | — | x | - | A | - | A | |
| | | F1-11 | Excessive Speed Deviation detection Delay Time (PG Deviate Time) | 0.0~10.0 | 0.1s | 0.5 | — | x | - | A | - | A | |
| | | F1-12 | Number of PG Gear Teeth 1 (PG # Gear Teeth 1) | 0~1000 | 1 | 0 | — | x | - | A | - | - | |
| | | F1-13 | Number of PG Gear Teeth 2 (PG # Gear Teeth 2) | 0~1000 | 1 | 0 | — | x | - | A | - | - | |
| | | F1-14 | PGO Detection Time (PGO Detect Time) | 0~10.0 | 0.1s | 2.0 | — | x | - | A | - | A | |
| | Function F2 AI-14 Setup | F2-01 | AI-14B Card Input Selection (AI-14 Input Sel) | 0, 1 | 1 | 0 | 0: (3-ch Individual) 1: (3ch Addition) | x | A | A | A | A | |
| * When access level is BASIC (A1-03), constant is not displayed unless the option is connected. | | | | | | | | | | | | | |

| Function | Parameter No. | Name (Digital Operator Display) | Setting Range | Setting Unit | Factory Setting | Remarks (Digital Operator Display) | Change during Operation o: Enabled x: Disabled | Parameter Access Level | | | | User Setting |
|---|-----------------|---|---------------|--------------|-----------------|---|--|------------------------|-----------|------------------|-------------|--------------|
| | | | | | | | | V/f | V/f w/ PG | Open Loop Vector | Flux Vector | |
| Group F Options* Function F3 DI-08, 16 Setup Function F4 AO-08, 12 | F3-01 | Digital Input Selection (DI Input) | 0~7 | 1 | 0 | 0: (BCD 1%) 1: (BCD 0.1%) 2: (BCD 0.01%) 3: (BCD 1Hz) 4: (BCD 0.1Hz) 5: (BCD 0.01Hz) 6: BCD Special setting 5 digit input, Binary 255/100% (BCD (5DG) 0.01Hz) 7: (Binary)* *Set value is displayed | x | A | A | A | A | |
| | F4-01 | Channel 1 Monitor Selection (AO Ch1 Select) | 1~38 | 1 | 2 | Analog Output option Channel 1 1: Frequency reference 2: Output frequency 3: Inverter output current 5: Motor speed 6: Output voltage 7: DC bus voltage 8: Output power 9: Torque reference (internal) 15: External terminal 13 input voltage 16: External terminal 14 input voltage 17: External terminal 16 input voltage 18: Motor secondary current (Iq) 19: Motor excitation current (Id) 20: Primary frequency after SFS 21: Speed controller ASR input 22: Speed controller ASR output 23: Speed deviation 24: PID feedback 26: Voltage reference (Vq out-put) 27: Voltage reference (Vd out-put) 32: ACR (q) Output 33: ACR (d) Output 36: PID Input <1110> 37: PID Output <1110> | x | A | A | A | A | |
| | F4-02 | Channel 1 Gain (AO Ch1 Gain) | 0.00~2.50 | 0.01 | 1.00 | — | o | A | A | A | A | |
| | F4-03 | Channel 2 Monitor Selection (AO Ch2 Select) | 1~38 | 1 | 3 | Analog Output option Channel 2 selection (same as F4-01) | x | A | A | A | A | |
| | F4-04 | Channel 2 Gain (AO Ch2 Gain) | 0.00~2.50 | 0.01 | 0.50 | — | o | A | A | A | A | |
| | F4-05 <1110> | CH1 Output Bias (AO Ch1 Bias) | -10.0~10.0 | 0, 1 | 0.0 | - | o | A | A | A | A | |
| | F4-06 <1110> | CH2 Output Bias | -10.0~10.0 | 0, 1 | 0.0 | - | o | A | A | A | A | |
| * When access level is BASIC (A1-03), constant is not displayed unless the option is connected. | | | | | | | | | | | | |

| Function | Parameter No. | Name (Digital Operator Display) | Setting Range | Setting Unit | Factory Setting | Remarks (Digital Operator Display) | Change during Operation o: Enabled x: Disabled | Parameter Access Level | | | | User Setting | | |
|-----------------|---------------------------------------|---------------------------------|---------------|---|-----------------|------------------------------------|--|---|-----------|------------------|-------------|--------------|---|--|
| | | | | | | | | V/f | V/f w/ PG | Open Loop Vector | Flux Vector | | | |
| Group F Options | Function F5 DO - 02 Setup | | F5-01 | Channel 1 Output Selection (DO-02 Ch1) | 00~37 | 1 | 0 | — | x | A | A | A | A | |
| | | | F5-02 | Channel 2 Output Selection (DO-02 Ch2 Select) | 00~37 <26> | 1 | 1 | — | x | A | A | A | A | |
| | Function F6 DO - 08 Setup | | F6-01 | Output Mode Selection (DO-08 Selection) | 0, 1 | 1 | 0 | 0: (8ch Individual) 1: (Binary Output) | x | A | A | A | A | |
| | Function F7 PO - 36F Setup | | F7-01 | Frequency Multiple Selection (PO-36F Selection) | 0~4 | 1 | 1 | 0: (1 X Output Freq) 1: (6 X Output Freq) 2: (10 X Output Freq) 3: (12 X Output Freq) 4: (36 X Output Freq) | x | A | A | A | A | |
| | Function F8 SI - F./G Setup | | F8-01 | SI-F/G Communication Error Detection Operation Selection (E-15 Det Sel) | 0~3 | 1 | 1 | 0: (Ramp to Stop) 1: (Coast to Stop) 2: (Fast - Stop) 3: (Alarm Only) | x | A | A | A | A | |
| | Function F9 CP-916 Setup / DDS • SI-B | | F9-01 | Option External Fault Selection (EFO Selection) | 0, 1 | 1 | 0 | 0: When 1 is shown, EFO occurs (Normally Open) 1: When 0 is shown, EFO occurs. (Normally Closed) | x | A | A | A | A | |
| | | | F9-02 | Option External Fault Detection Selection (EFO Detection) | 0, 1 | 1 | 0 | 0: (Always Detected) 1: (Only During Run) | x | A | A | A | A | |
| | | | F9-03 | Option External Fault Detection Operation Selection (EFO Fault Action) | 0~3 | 1 | 1 | 0: (Ramp to Stop) 1: (Coast to Stop) 2: (Fast - Stop) 3: (Alarm Only) | x | A | A | A | A | |
| | | | F9-04 | Trace Sampling Time (Trace Sample Tim) | 0~60000 | 1 | 0 | — | x | A | A | A | A | |
| | | | F9-05 | Torque Reference/Torque Limit Selection through DP-RAM communication (Torq Ref / Lmt Sel) | 0, 1 | 1 | 1 | 0: (Disabled) 1: (Enabled) | x | - | - | - | A | |
| | | | F9-06 | DP-RAM Communication Error Detection Operation Selection | 0~3 | 1 | 1 | 0: (Ramp to Stop) 1: (Coast to Stop) 2: (Fast - Stop) 3: (Alarm Only) | x | A | A | A | A | |

| Function | Parameter No. | Name (Digital Operator Display) | Setting Range | Setting Unit | Factory Setting | Remarks (Digital Operator Display) | Change during Operation o: Enabled x: Disabled | Parameter Access Level | | | | User Setting |
|---|---------------|---------------------------------------|---------------|--------------|--------------------|--|--|------------------------|-----------|------------------|-------------|--------------|
| | | | | | | | | V/f | V/f w/ PG | Open Loop Vector | Flux Vector | |
| Terminal Function Function H1 Digital Inputs | H1-01 | Terminal 3 Selection (Terminal 3 Sel) | 00~77 | 1 | 24 | Multi-function input (terminal 3) 0: 3-Wire Control 1: Local/Remote Selection 2: Option/Inverter Selection 3: Multi-Step Reference 1 4: Multi-Step Reference 2 5: Multi-Step Reference 3 6: Jog Frequency Reference 7: Multi-Accel/Decel 1 8: External Baseblock N.O. 9: External Baseblock N.C. A: Accel/Decel Ramp Hold B: OH2 Alarm Signal C: Terminal 16 Enable D: V/F Mode Select E: ASR Integral Reset F: Terminal Not Used 10: MOP Increase 11: MOP Decrease 12: Forward Jog 13: Reverse Jog 14: Fault Reset 15: Fast-Stop N.O. 16: Motor 2 Select 17: Fast Stop N.C. input <1110> 18: Timer Function 19: PID Disable 1A: Multi-Accel/Decel 2 1B: Program Lockout 1C: Trim Control Increase 1D: Trim Control Decrease 1E: Ref Sample Hold 1F: Terminal 13/14 Switch 24: External Fault 30: PID Integral Reset 31: PID Control Integral Hold <1110> 60: DC Injection Activate 61: Speed Search 1 62: Speed Search 2 63: Energy Save Mode 64: Speed Search 3 65: KEB Ridethrough N.C. 66: KEB Ridethrough N.O 71: Speed/Torque Control Change 72: Zero Servo Command 77: ASR Gain Switch | x | B | B | B | B | |
| | H1-02 | Terminal 4 Selection (Terminal 4 Sel) | 00~77 | 1 | 14 | Multi-function input (terminal 4) (same as H1-01) | x | B | B | B | B | |
| | H1-03 | Terminal 5 Selection (Terminal 5 Sel) | 00~77 | 1 | 3 (0) (Note 15) | Multi-function input (terminal 5) (same as H1-01) | x | B | B | B | B | |
| | H1-04 | Terminal 6 Selection (Terminal 6 Sel) | 00~77 | 1 | 4 (3) (Note 15) | — | x | B | B | B | B | |

| Function | Parameter No. | Name (Digital Operator Display) | Setting Range | Setting Unit | Factory Setting | Remarks (Digital Operator Display) | Change during Operation o: Enabled x: Disabled | Parameter Access Level | | | | User Setting |
|--|---------------|--|-----------------|--------------|--------------------|--|--|------------------------|-----------|------------------|-------------|--------------|
| | | | | | | | | V/f | V/f w/ PG | Open Loop Vector | Flux Vector | |
| Terminal Function Function H1 Digital Inputs | H1-04 | Terminal 6 Selection (Terminal 6 Sel) | 00~77 | 1 | 4 (3) (Note 15) | — | x | B | B | B | B | |
| | H1-05 | Terminal 7 Selection (Terminal 7 Sel) | 00~77 | 1 | 6 (4) (Note 15) | — | x | B | B | B | B | |
| | H1-06 | Terminal 8 Selection (Terminal 8 Sel) | 00~77 | 1 | 8 (6) (Note 15) | — | x | B | B | B | B | |
| Note 15: Factory settings in the parentheses are values obtained at 3-wire initialization. | | | | | | | | | | | | |
| Terminal Function H2 Digital Outputs | H2-01 | Multi-function Input Terminal 9-10 (Terminal 9 Sel) | 00~37 | 1 | 0 | Multi-function output 1 (terminal 9, terminal 10) | x | B | B | B | B | |
| | H2-02 | Multi-function Input Terminal 25 (Terminal 25 Sel) | 00~37 | 1 | 1 | Multi-function output 2 (terminal 25, terminal 27) (same as F5-01) | x | B | B | B | B | |
| | H2-03 | Multi-function Input Terminal 26 (Terminal 26 Sel) | 00~37 | 1 | 2 | Multi-function output 3 (terminal 26, terminal 27) (same as F5-01) | x | B | B | B | B | |
| | H3-01 | Signal Level Selection Terminal 13 (Term 13 Signal) | 0, 1 | 1 | 0 | 0: (0 - 10 VDC) 1: (-10 +10 VDC) | x | B | B | B | B | |
| | H3-02 | (Terminal 13 Gain) | 0.0~1000.0 | 0.1% | 100.0 | Frequency reference gain of AI-14U, AI-14B (3ch addition input), DI-08, and DI-16 is common. | o | B | B | B | B | |
| | H3-03 | (Terminal 13 Bias) | -100.0 ~ +100.0 | 0.1% | 0.0 | Frequency reference gain of AI-14U, AI-14B (3ch addition input), DI-08, and DI-16 is | o | B | B | B | B | |
| | H3-04 | Terminal 16 Signal Level Selection (Term 16 Signal) | 0, 1 | 1 | 0 | 0: (0 - 10 VDC) 1: (-10 +10 VDC) | x | B | B | B | B | |
| | H3-05 | Terminal 16 Multi- function Analog Input (Terminal 16 Sel) | 0~1F | 1 | 0 | Multi-function analog input selection (terminal 16) 0: Auxiliary Reference 1: Frequency Gain 2: Frequency Bias 4: Voltage Bias 5: Accel/Decel Change 6: DC Brake Current 7: Overtorque Level 8: Stall Prevention Level 9: Reference Lower Limit A: Jump Frequency B: PID Feedback C: PID Setpoint D: Frequency Bias 2 10: Forward Torque Limit 11: Reverse Torque Limit 12: Regenerative Torque Limit 13: Torque reference 14: Torque Compensation 15: Forward/Reverse Torque Limit 1F: Not Used | x | B | B | B | B | |

| Function | Parameter No. | Name (Digital Operator Display) | Setting Range | Setting Unit | Factory Setting | Remarks (Digital Operator Display) | Change during Operation o: Enabled x: Disabled | Parameter Access Level | | | | User Setting |
|---------------------------|----------------------------|---|---------------|--------------|-----------------|---|--|------------------------|-----------|------------------|-------------|--------------|
| | | | | | | | | V/f | V/f w/ PG | Open Loop Vector | Flux Vector | |
| Terminal | Analog Inputs | H3-06 (Terminal 16 Gain) | 0.0~1000.0 | 0.1% | 100.0 | — | o | B | B | B | B | |
| | | H3-07 (Terminal 16 Bias) | -100.0~+100.0 | 0.1% | 0.0 | — | o | B | B | B | B | |
| | | H3-08 Signal Level Selection Terminal 14 (Term 14 Signal) | 0, 1, 2 | 1 | 2 | 0: (0 - 10 VDC) 1: (-10 +10 VDC) 2: (4 - 20 mA) | x | A | A | A | A | |
| | | H3-09 Multi-function Analog Input Terminal 14 (Terminal 14 Sel) | 1~1F | 1 | 1F | The function choices for terminal 14 are the same as the choices for terminal 16 [see H3-05], except that [setting 0] "Auxiliary Reference" is not available. | x | A | A | A | A | |
| | | H3-10 Terminal 14 Gain (Terminal 14 Gain) | 0.0~1000.0 | 0.1% | 100.0 | — | o | A | A | A | A | |
| | | H3-11 Terminal 14 Bias (Terminal 14 Bias) | -100.0~+100.0 | 0.1% | 0.0 | — | o | A | A | A | A | |
| | | H3-12 Analog Input Filter Time Constant (Filter Avg Time) | 0.00~2.00 | 0.01s | 0.00 | — | x | A | A | A | A | |
| Group H Terminal Function | Function H4 Analog Outputs | H4-01 Monitor Selection Terminal 21 (Terminal 21 Sel) | 1~38 | 1 | 2 | Analog output selection (terminal 21 (same as F4-01) 1: Frequency reference 2: Output frequency 3: Inverter output current 5: Motor speed 6: Output voltage 7: DC bus voltage 8: Output power 9: Torque reference (internal) 15: External terminal 13 input voltage 16: External terminal 14 input voltage 17: External terminal 16 input voltage 18: Motor secondary current (Iq) 19: Motor excitation current (Id) 20: Primary frequency after SFS 21: Speed controller ASR input 22: Speed controller ASR output 23: Speed deviation 24: PID feedback 26: Voltage reference (Vq output) 27: Voltage reference (Vd output) 31: Not Used 32: ACR (q) Output 33: ACR (d) Output 36: PID Input <1110> 37: PID Output <1110> 38: PID Reference <1110> | x | B | B | B | B | |
| | | H4-02 Terminal 21 Output Gain (Terminal 21 Gain) | 0.00~2.50 | 0.01 | 1.00 | — | o | B | B | B | B | |

| Function | Parameter No. | Name (Digital Operator Display) | Setting Range | Setting Unit | Factory Setting | Remarks (Digital Operator Display) | Change during Operation o: Enabled x: Disabled | Parameter Access Level | | | | User Setting |
|--|---------------|--|---------------|--------------|-----------------|---|--|------------------------|-----------|------------------|-------------|--------------|
| | | | | | | | | V/f | V/f w/ PG | Open Loop Vector | Flux Vector | |
| Group H Terminal Function Function H4 Analog Outputs | H4-03 | Terminal 21 Output Bias (Terminal 21 Bias) | -10.0~+10.0 | 0.0% | 0.0 | — | o | B | B | B | B | |
| | H4-04 | Terminal 23 Monitor (Terminal 23 Sel) | 1~38 | 1 | 3 | Analog output selection (terminal 23) (same as H4-01) | x | B | B | B | B | |
| | H4-05 | Terminal 23 Output Gain (Terminal 23 Gain) | 0.00~2.50 | 0.01 | 0.50 | — | o | B | B | B | B | |
| | H4-06 | Terminal 23 Output Bias (Terminal 23 Bias) | -10.0~+10.0 | 0.1% | 0.0 | — | o | B | B | B | B | |
| | H4-07 | Analog Output Signal Selection (AO Level Select) | 0, 1 | 1 | 0 | 0: (0 - +10 VDC) 1: (-10V +10 VDC) | x | B | B | B | B | |
| Group H Terminal Function Function H5 Serial Com Setup MODBUS Communication | H5-01 | Station Address (Serial Comm Adr) | 0~20 | 1 | 1F | — | x | A | A | A | A | |
| | H5-02 | Communication Speed Selection (Serial Baud Rate) | 0~4 | 0 | 3 | 0 : (1200 Baud) 1 : (2400 Baud) 2 : (4800 Baud) 3 : (9600 Baud) 4 : (19200 Baud) <1110> | x | A | A | A | A | |
| | H5-03 | Communication Parity Selection (Serial Com Sel) | 0, 1, 2 | 1 | 0 | 0 : (No Parity) 1 : (Even Parity) 2 : (Odd Parity) | x | A | A | A | A | |
| | H5-04 | Stopping Method After Communication Error | 0~3 | 1 | 3 | 0: (Ramp to Stop) 1: (Coast to Stop) 2: (Fast - Stop) 3: (Alarm Only) | x | A | A | A | A | |
| | H5-05 | Timeover Detection (Serial Flt Dtct) | 0, 1 | 1 | 1 | 0 : (Disabled) 1 : (Enabled) | x | A | A | A | A | |

| Function | Parameter No. | Name (Digital Operator Display) | Setting Range | Setting Unit | Factory Setting | Remarks (Digital Operator Display) | Change during Operation o: Enabled x: Disabled | Parameter Access Level | | | | User Setting | |
|------------|---------------------------------------|---------------------------------|---|--------------|-----------------|------------------------------------|--|------------------------|-----------|------------------|-------------|--------------|--|
| | | | | | | | | V/f | V/f w/ PG | Open Loop Vector | Flux Vector | | |
| Protection | Function L1 Motor Overload | L1-01 | Motor Protection Selection (MOL Fault Select) | 0, 1 | 1 | 1 | 0: (Disabled) 1: (Coast to Stop) | x | B | B | B | B | |
| | | L1-02 | Motor Protection Time Constant (MOL Time Const) | 0.1~5.0 min. | 0.1 min. | 1.0 | When O2-09=1 [American Spec] the setting range is 0.1~20min. The factory default setting then becomes 8 min. 8 min. is the operation time from a cold start. | x | B | B | B | B | |
| | Function L2 Power Loss Ride Through | L2-01 | Momentary Power Loss Detection (PwrL Selection) | 0, 1, 2 | 1 | 0 | 0 : (Disabled) 1 : Power loss ride through (PwrL RideThru t) 2 : (CPU Power Active) | x | B | B | B | B | |
| | | L2-02 | Momentary Power Loss Ride Through (PwrL Ridethru t) | 0.0~2.0 | 0.1s | 0.7** | ** Factory setting differs depending on inverter capacity (02-04). | x | B | B | B | B | |
| | | L2-03 | Min. Baseblock Time (PwrL Baseblock t) | 0.1~5.0 | 0.1s | 0.5* | * Factory setting differs depending on inverter capacity. Lower limit of setting range is changed from 0 to 0.1. <1110> | x | B | B | B | B | |
| | | L2-04 | Voltage Recovery Time (PwrL V/F Ramp t) | 0.0~5.0 | 0.1s | 0.3* | * Factory setting differs depending on inverter capacity (02-04). | x | A | A | A | A | |
| | | L2-05 | Undervoltage Detection Level (PUV Det Level) | 150~210 | 1V | 190* | *Voltage Class 200V class=190V Det level 400V class=190V x 2= 380V level 575V class=190x575/200=546 level | x | A | A | A | A | |
| | | L2-06 | KEB Deceleration Rate (KEB Frequency) | 0.0~100.0 | 0.1% | 0.0 | — | x | A | A | A | A | |
| | Function L3 Stall Prevention Function | L3-01 | Stall Prevention During Acceleration (StallP Accel Sel) | 0, 1, 2 | 1 | 1 | 0: (Disabled) 1: (General Purpose) 2: (Intelligent) | x | B | B | B | - | |
| | | L3-02 | Stall Prevention Level During Acceleration (StallP Accel Lvl) | 0~200 | 1% | 150 | — | x | B | B | B | - | |
| | | L3-03 | Stall Prevention Limit During Acceleration (StallP CHP Lvl) | 0~100 | 1% | 50 | — | x | A | A | A | - | |

| Function | Parameter No. | Name (Digital Operator Display) | Setting Range | Setting Unit | Factory Setting | Remarks (Digital Operator Display) | Change during Operation o: Enabled x: Disabled | Parameter Access Level | | | | User Setting |
|------------|---|--|---------------|--------------|--|--|--|------------------------|-----------|------------------|-------------|--------------|
| | | | | | | | | V/f | V/f w/ PG | Open Loop Vector | Flux Vector | |
| Protection | Function L3 Stall Prevention Function | | | | | | | | | | | |
| | L3-04 | Stall Prevention During Deceleration (StallP Decel Sel) | 0, 1, 2, 3 | 1 | 1 | 0: (Disabled) 1: (General Purpose) 2: (Intelligent) <1110> can use setting 2 for all control modes A102=0,1,2,3 3: With braking resistor (Stall prev w/R) When in Vector w/PG A1-02=3 setting 3 cannot be set with braking resistor and with stall prevention. | x | B | B | B | B | |
| | L3-05 | Stall Prevention Selection during Running (StallP Run Sel) | 0, 1, 2 | 1 | 1 | 0: (Disabled) 1: (Decel Time 1) C1-02 2: (Decel Time 2) C1-04 | x | B | B | - | - | |
| | L3-06 | Stall Prevention Level during Running (StallP Run Level) | 30~200 | 1% | 160 | — | x | B | B | - | - | |
| | L3-07 | Stall Prevention Function P Gain (StallP Gain) | 0.10~2.00 | 0.01 | 1.00 | — | x | F | F | - | - | |
| | L3-08 | Stall Prevention Function Integral Time (StallP Intg Time) | 10~250 | 1 ms | 100 | — | x | F | F | - | - | |
| | Function L4 Reference Detection | | | | | | | | | | | |
| | L4-01 | Frequency Detection Level (Spd Agree Level) | 0.0~400.0 | 0.1Hz | 0.0 | — | x | B | B | B | B | |
| | L4-02 | Frequency Detection Width (Spd Agree Width) | 0.0~20.0 | 0.1Hz | 2.0 | — | x | B | B | B | B | |
| | L4-03 | Frequency Detection Level ± (Spd Agree Lvl ±) | -400.0~+400.0 | 0.1Hz | 0.0 | — | x | A | A | A | A | |
| | L4-04 | Frequency Detection Width ± (Spd Agree Wdth ±) | 0.0~20.0 | 0.1Hz | 2.0 | — | x | A | A | A | A | |
| | L4-05 | Frequency Loss Detection Selection (Ref Loss Sel) | 0, 1 | 1 | 0 | 0: (Stop) 1: (Run@ 80% PrevRef) | x | A | A | A | A | |
| | Function L5 Fault Restart | | | | | | | | | | | |
| L5-01 | Number of Auto Restart Attempts (Num of Restarts) | 0~10 | 1 | 0 | — | x | B | B | B | B | | |
| L5-02 | Auto Restart Operation Selection (Restart Sel) | 0, 1 | 1 | 0 | 0: (No Flt Relay) 1: (Flt Relay Active) | x | B | B | B | B | | |

| Function | Parameter No. | Name (Digital Operator Display) | Setting Range | Setting Unit | Factory Setting | Remarks (Digital Operator Display) | Change during Operation o: Enabled x: Disabled | Parameter Access Level | | | | User Setting | |
|------------|------------------------------|---------------------------------|---|--------------|-----------------|------------------------------------|---|------------------------|-----------|------------------|-------------|--------------|--|
| | | | | | | | | V/f | V/f w/ PG | Open Loop Vector | Flux Vector | | |
| Protection | Function L6 Torque Detection | L6-01 | Overtorque Detection Selection 1 (Torq Det 1 Sel) | 0~4 | 1 | 0 | 0: (Disabled) 1: (@SpdAgree - Alm) Detected during speed agree only. Operation continues after detection and OL3 flashes on display. 2: (At RUN - Alarm) Overtorque detection during running. Operation continues after detection and OL3 flashes on the display. 3: (@SpdAgree - Flt) Detected during the speed agree only. Inverter trips on OL3, output is shut OFF. 4: (At RUN - Fault) Detected during running, and the inverter trips on OL3. Output is shut OFF. | x | B | B | B | B | |
| | | L6-02 | Overtorque Detection Level 1 (Torq Det 1 Lvl) | 0~300 | 1% | 150 | — | x | B | B | B | B | |
| | | L6-03 | Overtorque Detection Time 1 (Torq Det 1 Time) | 0.0~10.0 | 0.1s | 0.1 | — | x | B | B | B | B | |
| | | L6-04 | Overtorque Detection Selection 2 (Torq Det 2 Sel) | 0~4 | 1 | 0 | 0: (Disabled) 1: (@SpdAgree - Alm) Detected during speed agree only. Operation continues after detection and OL4 flashes on display. 2: (At RUN - Alarm) Overtorque detection during running. Operation continues after detection and OL4 flashes on the display. 3: (@SpdAgree - Flt) Detected during the speed agree only. Inverter trips on OL4, output is shut OFF. 4: (At RUN - Fault) Detected during running, and the inverter trips on OL4. Output is shut OFF. | x | A | A | A | A | |
| | | L6-05 | Overtorque Detection Level 2 (Torq Det 2 Lvl) | 0~300 | 1% | 150 | — | x | A | A | A | A | |
| | | L6-06 | Overtorque Detection Time 2 (Torq Det 2 Time) | 0.0~10.0 | 0.1s | 0.1 | — | x | A | A | A | A | |
| | Function L7 Torq | L7-01 | Forward Torque Limit (Torq Limit Fwd) | 0~300 | 1% | 200 | — | x | - | - | B | B | |
| | | L7-02 | Reverse Torque Limit (Torq Limit Rev) | 0~300 | 1% | 200 | — | x | - | - | B | B | |

| Function | Parameter No. | Name (Digital Operator Display) | Setting Range | Setting Unit | Factory Setting | Remarks (Digital Operator Display) | Change during Operation o: Enabled x: Disabled | Parameter Access Level | | | | User Setting |
|---|--|--|---------------|--------------|--|--|--|------------------------|-----------|------------------|-------------|--------------|
| | | | | | | | | V/f | V/f w/ PG | Open Loop Vector | Flux Vector | |
| Protection Function L7 Torque Limit | L7-03 | Forward Regenerative Torque Limit (Torq Lmt Fwd Rgn) | 0~300 | 1% | 200 | — | x | - | - | B | B | |
| | L7-04 | Reverse Regenerative Torque Limit (Torq Lmt Rev Rgn) | 0~300 | 1% | 200 | — | x | - | - | B | B | |
| Protection Function L8 Hardware Protection | L8-01 | Internal DB Resistor Protection Selection (DB Resistor Prot) | 0, 1 | 1 | 0 | 0: (Not Provided) 1: (Provided) | x | B | B | B | B | |
| | L8-02 | Overheat Pre-alarm Level (OH Pre-Alarm Lvl) | 50~130 | 1 deg C | 95 C* | *Factory setting depends on inverter model [02-04]. | x | A | A | A | A | |
| | L8-03 | Operation Selection after OH Pre-alarm (OH Pre-Alarm Sel) | 0~3 | 1 | 3 | 0: (Ramp to Stop) using C1-02 1: (Coast to Stop) 2: (Fast-Stop) using C1-09 3: (Alarm Only) display flashes OH Heatsink Ovrtemp | x | A | A | A | A | |
| | L8-05 | Input Phase Loss Protection (PH Loss In Sel) | 0, 1 | 1 | 0 | 0: (Disabled) 1: (Enabled) | x | A | A | A | A | |
| | L8-07 | Output Phase Loss Protection (PH Loss Out Sel) | 0, 1 | 1 | 0* | 0: (Disabled) 1: (Enabled) *When 02-09=1, the factory default setting is 1. | x | A | A | A | A | |
| | L8-10 | Short-circuit Protection Selection (Ground Fault Sel) | 0, 1 | 1 | 1 | 0: (Disabled) 1: (Enabled) | x | A | A | A | A | |
| | L8-17 | IGBT Protection Selection at Low Frequency (Prtct@L - Spd) | 0, 1 | 1 | 1* | 0: Conventional 1: (Lower fc) Carrier frequency is decreased when f _{out} 10Hz and the load is > 100% iac. 2: (Short term OL2) OL occurs after 2 seconds during low speed [f _{out} £ 6Hz] current limit. 3: (I-Limit=150%) Current limit is set to 150% of the inverter rated current. < G5 plus > Addition * When 02-09=1 factory setting is 1. * When 02-09=2 factory setting is 2. | x | A | A | A | - | |
| L8-19 <1110> | OL2 Characteristics Selection at Low Speed (OL2 Chara@L-Spd) | 0, 1 | 1 | 0 | 0: (Disabled) Low frequency OL disabled 1: (Enabled) Low frequency OL enabled | x | A | A | A | A | | |

| Function | Parameter No. | Name (Digital Operator Display) | Setting Range | Setting Unit | Factory Setting | Remarks (Digital Operator Display) | Change during Operation o: Enabled x: Disabled | Parameter Access Level | | | | User Setting |
|----------------------------|---|--|---------------|--------------|--|---|--|------------------------|-----------|------------------|-------------|--------------|
| | | | | | | | | V/f | V/f w/ PG | Open Loop Vector | Flux Vector | |
| Operator | Function o1 Monitor Selection | | | | | Monitor selection 4: Control method 5: Motor speed 6: Output voltage 7: DC bus voltage 8: Output power 9: Torque reference (internal) 10: Input terminal status 11: Output terminal status 12: Internal Control Status 1 13: Elapsed time 14: Flash software ID number 15: External terminal 13 input voltage 16: External terminal 14 input voltage 17: External terminal 16 input voltage 18: Motor secondary current (Iq) 19: Motor excitation current (Id) 20: Primary frequency after SFS 21: Speed controller ASR input 22: Speed controller ASR output 23: Speed deviation 24: PID feedback 25: DI-16 reference 26: Voltage reference (Vq out-put) 27: Voltage reference (Vd out-put) 28: CPU ID number | o | B | B | B | B | |
| | 01-01 | Monitor Selection (User Monitor Sel) | 4~39 | 1 | 6 | | | | | | | |
| | 01-02 | Monitor Selection after Power Up (Power- On Monitor) | 1~4 | 1 | 1 | 1: (Frequency Ref) 2: (Output Freq) 3: (Output Current) 4: (User Monitor) | o | B | B | B | B | |
| | 01-03 | Frequency Units of Reference Setting and Monitor (Display) | 0~39999 | 1 | 0 | — | x | B | B | B | B | |
| | 01-04 | (Display Units) | 0, 1 | 1 | 0 | 0: (Hertz) 1: (RPM) | x | - | - | - | B | |
| | 01-05 | Parameter No. Display Selection (Address Display) | 0, 1 | 1 | 0 | 0: (Parameter Number) 1: (Memobus Address) | x | A | A | A | A | |
| | 02-01 | LOCAL/REMOTE Key Enable/Disable (Local/Remote) | 0, 1 | 1 | 1 | 0: (Disabled) 1: (Enabled) | x | B | B | B | B | |
| 02-02 | STOP Key Function Selection (Oper STOP Key) | 0, 1 | 1 | 1 | 0: (Disabled) When the inverter is operated from the digital operator. 1: (Enabled) Always enabled. | x | B | B | B | B | | |
| Function o2 Key Selections | | | | | | | | | | | | |

| Function | Parameter No. | Name (Digital Operator Display) | Setting Range | Setting Unit | Factory Setting | Remarks (Digital Operator Display) | Change during Operation o: Enabled x: Disabled | Parameter Access Level | | | | User Setting |
|---------------------------------------|---------------|--|---------------|--------------|-----------------|--|--|------------------------|-----------|------------------|-------------|--------------|
| | | | | | | | | V/f | V/f w/ PG | Open Loop Vector | Flux Vector | |
| Operator Function o2 Key Selection | 02-03 | User Parameter Initialization Selection (User Defaults) | 0, 1, 2 | 1 | 0 | 0: (No Change) Yaskawa default values used 1: (Set Defaults) Sets user specified value as default. 2: (Clear All) Clears user defaults | x | B | B | B | B | |
| | 02-04 | kVA Selection (Inverter Model #) | 0~FF | 1 | —* | * Not initialized. Sets the inverter capacity according to the model number. | x | B | B | B | B | |
| | 02-05 | Frequency Reference Setting Method Selection | 0, 1 | 1 | 0 | 0: (Disabled) 1: (Enabled) | x | A | A | A | A | |
| | 02-06 | Operation Selection When Digital Operator is Disconnected (Oper Detection) | 0, 1 | 1 | 0* | 0: (Disabled) Operation continues even if the digital operator is disconnected. 1: (Enabled) Inverter fault when the digital operator is disconnected. * When 02-09=1, the value is 1. | x | A | A | A | A | |
| | 02-07 | Elapsed Timer Setting (Elapsed Time Set) | 0~65535 | 1 hour | — | — | x | A | A | A | A | |
| | 02-08 | Elapsed Timer Selection (Elapsed Time) | 0, 1 | 1 | 0 | 0: (Power - On Time) 1: (Running Time) | x | A | A | A | A | |
| | 02-09 | Initialization Mode Selection (Init Mode Sel) | 0~3 | 1 | 0 | 0: (Japanese spec) 1: (American spec) 2: (European spec) 3: (OMRON spec) When 02-09 = 1 or 2, it is added by <1032>. When 02-09 = 0 or 3, it is added by <1040>. | x | A | A | A | A | |

2. Monitor Display (Un-XX)

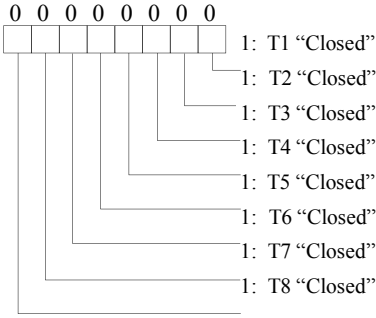
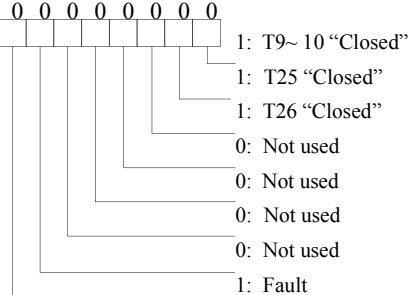
| Function | Parameter No. | Name (Digital Operator Display) | Min. Unit | Description | Analog Monitor Output Level | Parameter Access Level | | | |
|----------|---------------|---|-----------|---|-----------------------------|------------------------|-----------|---------------|--------------|
| | | | | | | V/f | V/f w/ PG | Vector w/o PG | Vector w/ PG |
| Monitor | U1-01 | Frequency Reference (Frequency Ref) | 0.01Hz | The unit differs depending on O1-03 setting. | 10V/Max. output frequency | Q | Q | Q | Q |
| | U1-02 | Output Frequency (Output Freq) | 0.01Hz | The unit differs depending on O1-03 setting. | 10V/Max. output frequency | Q | Q | Q | Q |
| | U1-03 | Output Current (Output Current) | 0.1A | Minimum unit is 0.01 A for 7.5 kW or less. | 10V/Inverter rated current | Q | Q | Q | Q |
| | U1-04 | Control Method* (Control) | — | 0: V/f control 1: V/f control with PG 2: Vector control without PG 3: Vector control with PG | — | Q | Q | Q | Q |
| | U1-05 | Motor Speed (Motor Speed) | 0.01Hz | The unit differs depending on O1-03 setting. | 10V/Max. output frequency | x | Q | Q | Q |
| | U1-06 | Output Voltage (Output Voltage) | 0.1V | — | 10V/200V or 400V ?575 | Q | Q | Q | Q |
| | U1-07 | DC Bus Voltage V (DC Bus Voltage) | 1V | — | 10V/400V or 800V | Q | Q | Q | Q |
| Monitor | U1-08 | Output Power (Output kWatts) | 0.1kW | — | 10V/Inverter capacity (kW) | Q | Q | Q | Q |
| | U1-09 | Torque Reference (Torque Reference) | 0.1% | — | 10V/Motor rated torque | x | x | Q | Q |
| | U1-10 | Input Terminal Status* (Input Term Sts) | — |  | — | Q | Q | Q | Q |
| | U1-11 | Output Terminal Status* (Output Term Sts) | — |  | — | Q | Q | Q | Q |

* Cannot be changed by U1-04

| Function | Parameter No | Name (Digital Operator Display) | Min. Unit | Description | Analog Monitor Output Level | Parameter Access Level | | | |
|----------|--------------|---|-----------|---|---------------------------------|------------------------|-----------|---------------|--------------|
| | | | | | | V/f | V/f w/ PG | Vector w/o PG | Vector w/ PG |
| Monitor | U1-12 | Operation Status* (Int Ctl Sts 1) | — | | — | Q | Q | Q | Q |
| | U1-13 | Elapsed Time* (Elapsed Time) | 1 hour | — | — | Q | Q | Q | Q |
| | U1-14 | Software No. at FLASH Side* (FLASH ID) | — | — | — | Q | Q | Q | Q |
| | U1-15 | Control Circuit Terminal 13 (Term 13 Level) | 0.1% | — | 10V/10V | B | B | B | B |
| | U1-16 | Control Circuit Terminal 14 Input Voltage (Term 14 Level) | 0.1% | — | 10V/10V or 20 mA | B | B | B | B |
| | U1-17 | Control Circuit Terminal 16 Input (Terminal 16 Level) | 0.1% | — | 10V/10V | B | B | B | B |
| | U1-18 | Motor Secondary Current (Iq) (Mot SEC Current) | 0.1% | — | 10V/Motor rated primary current | B | B | B | B |
| | U1-19 | Motor Excitation Current (Mot EXC Current) | 0.1% | — | 10V/Motor rated primary current | x | x | B | B |
| | U1-20 | Output Frequency after Soft-start (SFS Output) | 0.01Hz | — | 10V/Max. output frequency | A | A | A | A |
| | U1-21 | ASR Input (ASR Input) | 0.01% | — | 10V/Max. output frequency | x | A | x | A |
| | U1-22 | ASR Output (ASR Output) | 0.01% | Analog monitor output level becomes 10V/Max. output frequency for V/f control mode with PG. | 10V/Motor rated primary current | x | A | x | A |
| | U1-23 | Speed Deviation (Speed Deviation) | 0.01% | — | 10V/Max. output Frequency | x | A | x | A |
| | U1-24 | PID Feedback Capacity (PID Feedback) | 0.01% | — | 10V/Max. output Frequency | A | A | A | A |

| Function | Parameter No. | Name (Digital Operator Display) | Min. Unit | Description | Analog Monitor Output Level | Parameter Access Level | | | |
|----------|-----------------|---|-----------|---|-----------------------------|------------------------|-----------|---------------|--------------|
| | | | | | | V/f | V/f w/ PG | Vector w/o PG | Vector w/ PG |
| Monitor | U1-25 | D1-16H Input Status* (DI-16 Reference) | — | Displays input value according to F3-01 setting. For example: When lower 8 bit is ON, Binary selection: 256, BCD selection: 99 | — | A | A | A | A |
| | U1-26 | Output Voltage Reference Vq (Voltage Ref (Vq)) | 0.1V | — | 10V/200V or 400V | x | x | A | A |
| | U1-27 | Output Voltage Reference Vd (Voltage Ref (Vd)) | 0.1V | — | 10V/200V or 400V | x | x | A | A |
| | U1-28 | Software No. at CPU Side* (CPU ID) | — | — | — | A | A | A | A |
| | U1-32 | ACR (q) Output (ACR (q) Output) | 0.1% | — | — | x | x | A | A |
| | U1-33 | ACR (d) Output (ACR (d) Output) | 0.1% | — | — | x | x | A | A |
| | U1-34 | OPE Detection Parameter* (OPE Detected) | — | — | — | A | A | A | A |
| | U1-35 | No. of O Servo Moving Pulses (Zero Servo Pulse) | 1 | — | — | x | x | x | A |
| | U1-36 <1110> | PID Deviation (PID Input) | 0.01% | PID reference + PID reference bias – PID feedback capacity | 10V/Max. Output Frequency | A | A | A | A |
| | U1-37 <1110> | PID Output Capacity (PID Output) | 0.01% | PID output capacity | 10V/Max. Output Frequency | A | A | A | A |
| | U1-38 <1110> | PID Reference (PID Setpoint) | 0.01% | PID reference + PID reference bias | 10V/Max. Output Frequency | A | A | A | A |
| | U1-39 <1110> | Temperature for Cooling Fin (Heatsink Temp) | 1 C | — | — | F | F | F | F |

* Cannot be changed by U1-04

| Function | Parameter No. | Name (Digital Operator Display) | Min. Unit | Description | Analog Monitor Output Level | Parameter Access Level | | | |
|----------|---------------|---|-----------|--|-----------------------------|------------------------|-----------|---------------|--------------|
| | | | | | | V/f | V/f w/ PG | Vector w/o PG | Vector w/ PG |
| Monitor | U2-01 | Current Fault (Current Fault) | — | — | — | Q | Q | Q | Q |
| | U2-02 | Last Fault (Last Fault) | — | — | — | Q | Q | Q | Q |
| | U2-03 | Frequency Reference at Fault (Frequency Ref) | 0.01Hz | — | — | Q | Q | Q | Q |
| | U2-04 | Output Frequency at Fault (Output Freq) | 0.01Hz | — | — | Q | Q | Q | Q |
| | U2-05 | Output Current at Fault (Output Current) | 0.1A | — | — | Q | Q | Q | Q |
| | U2-06 | Motor Speed at Fault (Motor Speed) | 0.01Hz | — | — | x | Q | Q | Q |
| | U2-07 | Output Voltage Reference at Fault (Output Voltages) | 0.1V | — | — | Q | Q | Q | Q |
| | U2-08 | DC Bus Voltage at Fault (DC Bus Voltage) | 1V | — | — | Q | Q | Q | Q |
| | U2-09 | Output Power at Fault (Output kWatts) | 0.1kW | — | — | Q | Q | Q | Q |
| | U2-10 | Torque Reference at Fault (Torque Reference) | 0.1% | — | — | x | x | Q | Q |
| | U2-11 | Input Terminal Status at Fault (Input Term Sts) | — | Displays the same status as the U1-10. | — | Q | Q | Q | Q |
| | U2-12 | Output Terminal Status at Fault (Output Term Sts) | — | Displays the same status as the U1-11. | — | Q | Q | Q | Q |
| | U2-13 | Operation Status at Fault (Inverter Status) | — | Displays the same status as the U1-12. | — | Q | Q | Q | Q |
| | U2-14 | Elapsed Operation Time at Fault (Elapsed Time) | 1 hour | — | — | Q | Q | Q | Q |

| Function | Parameter No. | Name (Digital Operator Display) | Min. Unit | Description | Analog Monitor Output Level | Parameter Access Level | | | |
|---------------------------|---------------|---|-----------|-------------|-----------------------------|------------------------|-----------|---------------|--------------|
| | | | | | | V/f | V/f w/ PG | Vector w/o PG | Vector w/ PG |
| Function U3 Fault History | U3-01 | Current Fault (Current Fault) | — | — | — | Q | Q | Q | Q |
| | U3-02 | Last Fault (Last Fault) | — | — | — | Q | Q | Q | Q |
| | U3-03 | Frequency Reference at Fault (Frequency Ref) | — | — | — | Q | Q | Q | Q |
| | U3-04 | Output Frequency at Fault (Output Freq) | — | — | — | Q | Q | Q | Q |
| | U3-05 | Output Current at Fault (Output Current) | 1 hour | — | — | Q | Q | Q | Q |
| | U3-06 | Motor Speed at Fault (Motor Speed) | 1 hour | — | — | Q | Q | Q | Q |
| | U3-07 | Output Voltage Reference at Fault (Output Voltages) | 1 hour | — | — | Q | Q | Q | Q |
| | U3-08 | DC Bus Voltage at Fault (DC Bus Voltage) | 1 hour | — | — | Q | Q | Q | Q |