

preface

Thank you for using the FST-820 series elevator special inverter of Anyhertz Drive (Shenzhen) Co.,Ltd. FST-820 series elevator special inverter is a new generation of high-performance elevator special vector control inverter independently developed and produced by our company. It is many years of elevator application industry experience precipitation combined with motor vector control, smooth curve calculation and other advanced algorithms and the birth of the product, is the elevator industry is the most practical, the most professional, the most easy to use dedicated frequency converter! Its main features are as follows:

- ◆ Suitable for permanent magnet synchronous motor and asynchronous motor drive control, with a variety of rotary encoder interfaces;
- ◆ With the self-tuning function of motor parameters, it can be static tuning or complete tuning;
- ◆ Flexible start curve processing, multi-section S curve setting, 4-level acceleration and deceleration time setting can ensure good elevator operation comfort;
- ◆ With a simple and practical battery operation function, 48V power input can complete the power outage self-rescue;
- ◆ It has a variety of special functions such as enabling detection, lock contactor control, contactor control, output contact control, forced deceleration judgment, overspeed protection, speed deviation detection, early door opening, contact adhesion detection, motor overheating detection, starting pre-torque compensation and other elevator special functions, making the elevator control become simple and easy to operate;
- ◆ The unique single-key design of the operation panel makes the complex keyboard operation easy; and can be connected to any position through the RJ45 port, making the elevator debugging more convenient and simple; the parameter copy unit is easy to use for batch debugging;
- ◆ Built-in DC reactor and brake unit, improve the output power factor of the system, reduce the cost of external distribution parts of the electrical system;
- ◆ The whole series of independent air duct design, professional lightning protection design, professional processing platform, advanced process control to ensure the quality of FST-820 elevator special frequency converter;

Please read and understand this instruction manual carefully before using the FST-820 series inverter. This manual is attached for random delivery.

The contents of this manual have been confirmed at the time of printing, but we are committed to the continuous improvement and improvement of the product, so we reserve the right to modify the product specifications, performance and other contents of this manual, subject to change without notice.

Shenzhen Foster Technology Co., Ltd. provides customers with a full range of technical support, if in doubt, customers can contact the Foster product sales center or customer service center.

Catalogue

preface	1
Chapter I : Safety information and precautions	4
1.1 Security matters.....	4
1.2 matters need attention.....	6
Chapter II : on-product information	9
2.1 Naming Rules.....	9
2.2 The nameplate.....	9
2.3 FST-820 series frequency converter model.....	9
2.4 Technical Specification.....	10
2.5 Product appearance and installation hole size (including IP model).....	12
2.6 Selection parts (including IP models).....	13
2.7 Daily maintenance and maintenance of frequency converter.....	13
2.8 Warranty description of the frequency converter.....	15
Chapter III: Installation and wiring	16
3.1 Mechanical installation.....	16
3.2 Electrical part installation.....	17
3.3 Handling of E M C problems.....	30
Chapter IV: Operation and commissioning	32
4.1 Term ology of 1820 series frequency converter.....	32
4.2 Introduction of the operation and display interface.....	33
4.3 Description of function code reading and operation method.....	34
4.4 Operation mode of the shortcut menu.....	35
4.5 Password setting.....	37
4.6 Automatic tuning of the motor parameters.....	38
Chapter V: Functional Parameter Table	39
5.1 Functional Parameter Table.....	39

5.2, Features Table	39
Chapter VI: Application and Commissioning	55
6.1 Multisegment speed control mode	55
6.2 Simulation quantity control mode	60
6.3 Repair and operation	61
6.4 Power outage emergency operation	63
6.5 Simulation volume weighing and debugging	65
6.6 No weighing and debugging method	66
Chapter VII: Fault Diagnosis and Countermeasures	67
7.1 Fault alarm and countermeasures	67
7.2 Common faults and their handling methods	67

Chapter I : Safety information and precautions

Security definition:

In this manual, the safety precautions fall into two categories:



Risk: the danger caused by not operating as required, which may lead to child injury, or even death;



Note: The danger caused by no required operation may lead to moderate injury or minor injury, and equipment damage;

When installing, commissioning and repairing the system, please read this chapter carefully and be sure according to the safety precautions required in this chapter. Any damage or loss caused by the illegal operation is not related to the Company.

1.1 Security matters

1.1.1 Before installation



danger

- Do not use the damaged frequency converter or the missing part of the inverter. In danger of injury!

1.1.2 When installing



danger

- Install on flame retardant objects such as metal; away from combustible. Otherwise, it may cause a fire alarm!



pay attention to

- When two or more frequency converters are placed in the same cabinet, please pay attention to the installation position (refer to Chapter 3, mechanical and electrical installation), to ensure the heat dissipation effect.
- Do not let the wire head or screw fall into it. Otherwise, the inverter will be damaged!
- Install the frequency converter where vibration is less to avoid direct sunlight.

1.1.3 When wiring



danger

- The guidance of this manual must be followed and constructed by professional electrical engineers, otherwise an unexpected danger will occur!
- A circuit breaker must be separated between the frequency converter and the power supply, otherwise a fire alarm may occur!
- Please confirm that the power supply is at zero energy before wiring, otherwise there is a danger of electric shock!
- Please ground the frequency converter correctly according to the standard, otherwise there is a danger of electric shock!

**danger**

- The input power supply must never be connected to the inverter output terminal (U, V, W). Pay attention to the mark of the wiring terminal, do not connect the wrong line, otherwise cause the inverter damage!
- Ensure that the lines meet EMC requirements and safety standards in the area. Refer to the manual. Otherwise, an accident may occur!
- The brake resistance must not be connected directly between the DC bus (+) and (-) terminals. Otherwise cause fire!

1.1.4 Before the power-on

**pay attention to**

- Please confirm that the voltage level of the input power supply is consistent with the rated voltage level of the frequency converter; the wiring position on the power input terminal (R, S, T) and output terminal (U, V, W) is correct; and check for short circuit in the peripheral circuit connected to the frequency converter; whether the connected line is fastened. Otherwise, the inverter will be damaged!
- Any part of the inverter does not need to withstand voltage test, the factory. Otherwise, it will cause an accident!

**danger**

- The frequency converter must cover well before electrification, otherwise it may cause electric shock!
- The wiring of all peripheral accessories must follow the instructions of this manual and connect correctly in accordance with the circuit connection method provided in this manual. Otherwise, it will cause an accident! Ensure that the lines meet EMC requirements and safety standards in the area. Refer to the manual. Otherwise, an accident may occur!

1.1.5 After the power is turned on

**danger**

- Do not open the cover plate after charging. Otherwise, there is the danger of electric shock!
- Do not touch the frequency converter and the surrounding circuits with a wet hand. Otherwise, there is electric shock!
- Do not touch any input / output terminals of the frequency converter. Otherwise, there is electric shock!
- At the beginning of power, the converter automatically detects the external strong electric circuit. At this time, never touch the converter U, V, W terminal or motor terminal, otherwise there is a danger of electric shock!

**danger**

- If parameter identification is required, please pay attention to the danger of injury during motor rotation. Otherwise, it may cause an accident!
- Do not change the parameters. Otherwise, damage may cause equipment!

1.1.6 In-operation

**danger**

- Do not touch the cooling fan and the discharge resistance to test the temperature. Otherwise, it may cause burns!
- Non-professional technicians do not detect signals during operation. Otherwise, it may cause personal damage or equipment damage!

**pay attention to**

- During the inverter operation, something should be avoided from falling into the equipment. Otherwise, cause equipment damage!
- Do not use the contactor on and break method to control the start and stop of the frequency converter. Otherwise, cause equipment damage!

1.1.7 During maintenance

**danger**

- Do not repair and maintain the equipment with electricity. Otherwise, there is electric shock!
- Verify that the inverter can be maintained and repaired only after the inverter CHARGE lamp is turned off. Otherwise, the residual charges on the capacitor will cause harm to people!
- Personnel without professional training do not repair and maintain the frequency converter. Otherwise, cause personal injury or equipment damage!

1.2 matters need attention

1.2.1 Motor insulation inspection

Motor insulation inspection should be done before the first use and after regular placement, to prevent damage to the inverter due to the insulation failure of the motor winding. During the insulation inspection, the motor connection must be separated from the frequency converter. It is recommended to adopt a 500V voltage type watt-euro meter to ensure that the measured insulation resistance is more than 5 MΩ.

1.2.2 Thermal protection of the motor

If the rated capacity of the motor and the inverter do not match, especially when the rated power of the inverter is greater than the rated power of the motor, be sure to adjust the value of the motor protection parameters in the inverter or install a heat relay in front of the motor to protect the motor.

1.2.3 Operation above the power frequency

Do not use it above the power frequency. If the customer runs above 50Hz, please consider the strength and life of each escalator machinery.

1.2.4 Heating and noise of electric motor

Because the output voltage of the frequency converter is PWM wave, which contains a certain harmonic wave, so the temperature rise, noise and vibration of the motor will be slightly increased compared with the power frequency operation.

1.2.5 Pressure-sensitive devices or improved power factor capacitance on the output side

The output of the frequency converter is PWM wave. If the output side is installed with improved power factor capacitance or voltage transistor for lightning protection, it is easy to cause the instantaneous overcurrent or even damage to the frequency converter. Please don't use it.

1.2.6 Switch devices such as contactors used in the input and output terminals of the frequency converter

If a contactor is installed between the power supply and the input end of the inverter, it is not allowed to control the start and stop of the inverter. Frequent charge and discharge can easily reduce the service life of the capacitor in the frequency converter. If switching devices such as contactors are installed between the output and the motor, ensure that the frequency converter operates when there is no output. It is not allowed to absorb the contactor when the frequency converter is output, otherwise damage the module in the frequency converter.

1.2.7 Use beyond the rated voltage value

If the external voltage is not within the allowable working voltage range specified in the manual, use, 860 elevator inverter, all-in-one machine, easy to cause damage to the devices in the inverter. If required, use the appropriate boost or down device.

1.2.8 Three-phase input is changed to two-phase input

Do not change the 820 series three-phase inverter to two-phase use, otherwise it will cause failure or damage to the frequency converter.

1.2.9 Lightning impact protection

This series of frequency converter is equipped with lightning overcurrent protection device, which has a certain self-protection ability for lightning induction. For lightning frequent customers should also be installed in the front end of the frequency converter protection.

1.2.10 Elevation and elevation

In the altitude of more than 1000 meters, the cooling effect of the frequency converter caused by the thin air is poor, so it is necessary to use the forehead, please ask our company for technical consultation.

1.2.11, Some special uses

Please consult us if the customer uses methods other than the suggested wiring diagram provided in this manual.

1.2.12 Pay attention to it when scrapping the inverter

An explosion may occur on the electrolytic capacitance of the main circuit and on the printed board. Plastic parts can produce toxic gases when burned. Please treat it as industrial waste.

1.2.13 About the adaptive motor

(1) The 820 series elevator special inverter standard adaptive motor is the four-pole rat cage type asynchronous induction motor, and the IP model is suitable for the permanent magnet synchronous motor. For the optional motor, please note that the rated current of the motor is in the available range of the frequency converter;

- (2) The cooling fan of the non-frequency conversion motor and the rotor shaft are coaxial connection, the cooling effect of the fan is reduced when the speed decreases, therefore, the motor overheating occasion should be equipped with a strong exhaust fan or replaced with the frequency conversion motor;
- (3) For Asynchronous motor inverter with a motor parameter, it is necessary to identify the motor parameter value according to the actual situation or to modify the default value as much as possible, otherwise it will affect the operation effect and protection performance; permanent magnet synchronous motor must conduct dynamic parameter identification;
- (4) A short circuit inside the cable or the motor will cause the frequency converter to alarm, or even blast the machine. Therefore, please first conduct the insulation short circuit test on the initially installed motor and cable, which should also be conducted frequently in daily maintenance. Note that when doing this test connect the inverter from the test part.

Chapter II : on-product information

This chapter introduces the relevant information of the components of the 820 series elevator special inverter, daily use and maintenance, and product selection guidance, which helps users to ensure the safe use of the product.

2.1 Naming Rules

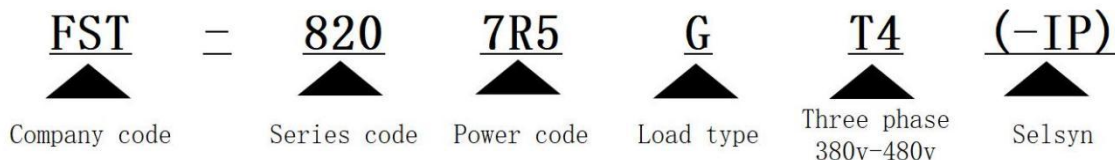

2.2 The nameplate

The 820 series inverter nameplate is suitable for asynchronous motors

M O D E L : FST-820-7R5GT4
I N P U T : 3PH AC380-440V 50/60HZ
O U T P U T : 3PH ACO-440V 7.5KW 18A
Freq.Range: 0-99Hz

820 series inverter nameplate for synchronous motor

M O D E L : FST-820-7R5GT4 - IP
I N P U T : 3PH AC380-440V 50/60HZ
O U T P U T : 3PH ACO-440V 7.5KW 18A
Freq.Range: 0-99Hz

2.3 FST-820 series frequency converter model

Model.	Power supply capacity (kVA)	input currenton (A)	output (A)	Adapter motor (kW)
Three-phase 380V range: -15%~20%				
FST-820-5R5GT4	8.9	14.6	13.0	5.5
FST-820-7R5GT4	11.0	20.6	18.0	7.5
FST-820-011GT4	17.0	29.0	27.0	11
FST-820-015GT4	21.0	23.0	33.0	15

2.4 Technical Specification

project	specifications			
Basic specifications	carrier frequency	0.5k 16k (Hz); automatically adjust the carrier frequency according to the load characteristics.		
	Input the frequency resolution	Number setting: 0.01Hz Simulation setting: Maximum frequency of * 0.1%		
	Output frequency accuracy	Number setting: Maximum frequency x $\pm 0.01\%$ Simulation setting: Maximum frequency * $\pm 0.01\%$		
	control method	Open Ring Vector Control (SVC) / closed loop vector control (VC) / VF control		
	pull-in torque	0.5HZ/180% (SVC); 0Hz/200% (VC)		
	Speed range	1: 100 (SVC)	1: 1000 (VC)	
	Steady speed accuracy	$\pm 0.5\%$ (SVC)	$\pm 0.05\%$ (VC)	
	overload capacity	150% Rated for 60 seconds; 180% for 1 second.		
	Add deceleration curve	Straight or S curve acceleration and deceleration mode; four groups of acceleration and deceleration time and four sets of S curve setting; multiple combinations		
	Maintenance control	You can be specified at any multiple speed		
	Multi-section speed operation	Up to 8 segments of speed operation		
	Automatic Voltage Adjustment (AVR)	When the grid voltage changes, the output voltage constant		

project		specifications
Display and operation	LED show	The parameter that can display the set frequency, output frequency, output voltage, and output current
	The LCD display operation panel	Select accessories, prompt in Chinese / English
	Parameter copy	Use the LCD action panel for a quick replication of the parameters
	defensive function	Upper power short circuit detection, input and output lack of phase protection, overcurrent protection, overvoltage protection, undervoltage protection and other 40 kinds of protection
	Key-lock and function selection	Locout part or all of the keys and define the range of action of some keys to prevent misoperation
Personalization function	Safety self-inspection of power-on peripheral equipment	It can realize the safety detection of the peripheral equipment, such as grounding, short circuit, etc
	Power outage emergency operation	The emergency operation scheme is simple and convenient
	overspeed protection	Built-in elevator overspeed protection function; various action choices
	Judgment speed deviation	Built-in speed deviation detection function; timely find the potential hidden dangers of the elevator
	Strong and urgent speed function	Has the function of forced speed detection; effectively prevent the elevator roof squat
	Motor temperature detection	Determine the motor temperature in time to eliminate potential safety risks
	Start compensation	Two ways of starting torque compensation; analog or digital quantity
	QUICK key	The User freely defines the shortcut menu
	timing control	Convenient to realize the timing control function
Input and output characteristics	Run the command channel	Three channels: operation panel given, control terminal given, communication given
	frequency source	There are five frequency sources: digital given, analog voltage given, analog current given, communication given, multiple segment speed given
	input terminal	10 Road Digital input terminal, crane 1 road can be a high-speed pulse input, can be compatible with active PNP or NPN input mode

project		specifications
		Three analog input terminals, one can only be used as voltage input and the other for voltage or current input
	leading-out terminal	3 digital output terminal The 2-way relay output terminal Two analog output terminals, either 0 / 4~20mA or 0 / 2~10V respectively, can realize the force-free output of set frequency and output frequency
environment	above sea level	Region of 1,000 meters
	ambient temperature	-10℃ ~40℃ (ambient temperature again 40℃ ~50℃, please decrease the amount for use)
	humidity	Less than 95%RH, unboiled condensation
	vibrate	Less than 5.9 m / sec. ² (0.6g)
	storage temperature	-20℃~60℃

2.5 Product appearance and installation hole size (including IP model)

2.5.1 820 Product appearance:

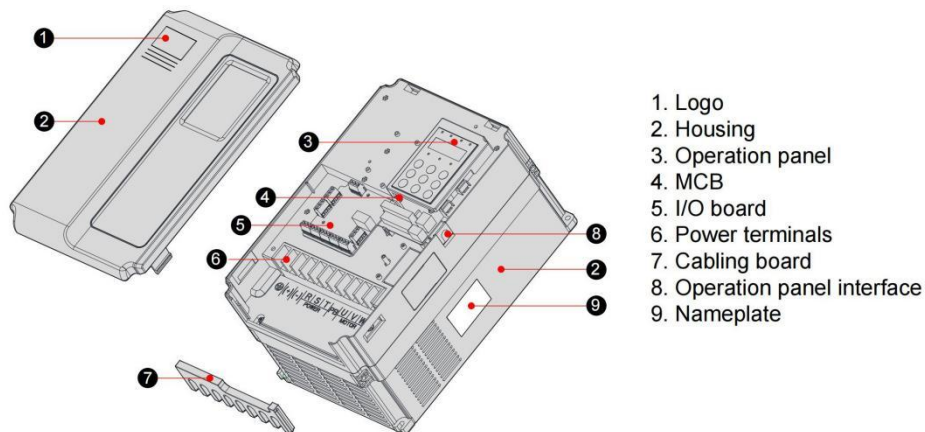

Figure 2-4 820 inverter appearance diagram

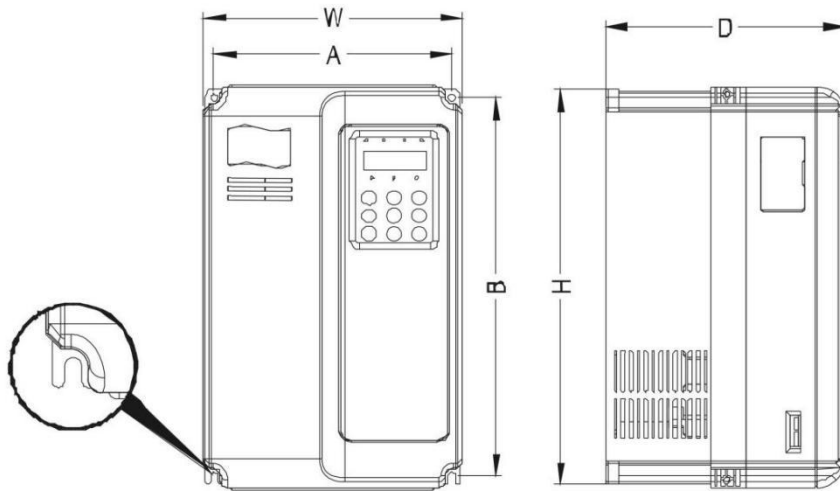

Figure 2-5 820 Schematic diagram of external size and installation size of frequency converter

2.5.2 820 Installation hole size (including IP model)

Model	A (mm)	B (mm)	H (mm)	W (mm)	D (mm)	aperture (mm)	rough weight (kg)
FST-820-5R5GT4	148	236	248	160	183	Φ5	4.2
FST-820-7R5GT4	190	304	320	205	195	Φ10	6.44
FST-820-011GT4	190	304	320	205	195	Φ10	6.44
FST-820-015GT4	190	304	320	205	195	Φ10	6.44

2.6 Selection parts (including IP models)

name	model	function	remarks
PG block	MCTC-PG-A	Rotate the encoder interface card and the frequency division output	Provide 15V power supply, suitable for push-pull or open-circuit collector output
	MCTC-PG-B	Rotate the encoder interface card and the frequency division output	Adapt long line drive incremental encoder, UVW encoder; frequency fixed 1 frequency;
	MCTC-PG-C	Rotate the encoder interface card	Provide 5V power supply, sin, cos type encoder
Parameter copy unit	ME-CP	Parameter copy	Adopt the general-purpose RJ45 interface
External	MDKE	The External Introduction LED	Use RJ45 interface for over long distance
Extend the cable	MDCAB	Standard 8 core network cable	Provides 1 meter, 3 meters and other

Detailed functions and instructions for the selections.

If you need the above optional accessories, please explain when ordering, thank you!

2.7 Daily maintenance and maintenance of frequency converter

2.7.1 Daily maintenance

Due to the influence of environmental temperature, humidity, dust and vibration, the devices inside the converter will aging, which may cause potential failure of the converter or reduce the service life of the converter. Therefore, it is necessary to carry out daily and regular maintenance and maintenance of the frequency converter.



pay attention to

- After the power supply is disconnected, because the inverter is still high voltage on the filter capacitor, it cannot be repaired or maintained immediately. Must wait until the CHARGE light is off after the multimeter test bus voltage does not exceed 36V.

1) Daily inspection items:

- a. Any abnormal sound changes during the motor operation.
- b. Does the vibration occur during the motor operation.
- c. Whether the installation environment of the frequency converter changes.
- d. Does the inverter cooling fan work normally.
- e. Is the frequency converter overheating not.

2) Daily cleaning:

- a. The inverter shall be kept clean at all times.
- b. Effectively remove the surface area of the converter to prevent dust from entering the converter. Especially with the metal dust.
- c. Effectively remove the oil pollution from the frequency converter heat dissipation fan.

2.7.2 Regular inspection

Please check the places that are difficult to check during the operation of frequency converter.

Regular inspection items:

- d. Check the air duct, and clean it regularly
- e. Check whether the screws are loose
- f. Check the frequency converter for corrosion
- g. Check the terminal for arc marks
- h. Main loop insulation test



pay attention to

- When measuring the insulation resistance with a meu u meter (please use a DC 500V meu meter), remove the main return route from the frequency converter. Do not test the control loop insulation with an insulation resistance meter. High pressure test is not required (done at factory).

2.7.3 Replacement of vulnerable parts of frequency converter

The vulnerable parts of frequency converter mainly include cooling fan and electrolytic capacitor for filter, whose life is closely related to the service environment and maintenance condition. General life times are:

Device name	Life time	Possible cause of the damage	Discrimination standard
electric fan	2 Adventitia 3 years	Bearing wear, blade aging	Whether there are cracks in the fan blade, and whether there is abnormal
electrolytic capacitor	4 Adventitia 5 years	Input power supply has poor quality, high ambient temperature, frequent load	Whether there is liquid leakage, whether the safety valve is convex,

2.7.4 Storage of frequency converter

After purchasing the frequency converter, the temporary storage and long-term storage must pay attention to the following points:

- 1) Try to put it into the company's packaging box according to the original packaging during storage.
- 2) A long time of storage will lead to the deterioration of the electrolytic capacitor. It must be connected within 2 years, and the power-up time is at least 5 hours. The input voltage must be slowly raised to the rated value with the voltage regulator.

2.8 Warranty description of the frequency converter

The free warranty refers only to the frequency converter itself.

- 1) In case of failure or damage under normal use, our company is responsible for 18 months of warranty (from the date of manufacturing, according to the bar code on the equipment shall prevail), for more than 18 months, reasonable maintenance fees will be charged;
- 2) Within 18 months, certain maintenance fees shall be charged in case of the following circumstances:
 - a. Machine damage caused by the user not to follow the provisions in the use manual;
 - b. Damage caused by fire, flood disaster and abnormal voltage;
 - c. Damage caused when using the frequency converter for abnormal function;
 - d. The relevant service fee shall be calculated according to the unified standard of the manufacturer. If there is a contract, it shall be dealt with on the principle of contract priority.

Chapter III: Installation and wiring

Before the installation of the frequency converter, it must be open from the box for inspection. Earnestly confirm:

Whether the model of the machine nameplate and the rated power of the frequency converter are consistent with your order. The box contains the purchased machine, product certificate, user manual and warranty form.

Products are damaged during transportation; if any omission or damage is found, please contact our company or your agent quickly.

Note: The installation and wiring of the frequency converter should strictly comply with the safety and precautions in Chapter 1.

3.1 Mechanical installation

3.1.1 Installation environment:

- (1) Ambient temperature: the ambient ambient temperature has a great impact on the life of the frequency converter, and the operating ambient temperature of the frequency converter is not allowed to exceed the allowable temperature range (-10°C 50°C)
- (2) Install the frequency converter on the surface of the flame retardant object with enough space for heat dissipation around. The converter is easy to produce a lot of heat when working. Install vertically on the mounting mount with screws.
- (3) Please install in without vibration. The vibration shall not be greater than 0.6G. Pay special attention to stay away from the punch machine and other equipment.
- (4) Avoid places in direct sunlight, damp, water.
- (5) Avoid installing them in places with corrosive, flammable and explosive gases in the air.
- (6) Avoid installing it in places with oil pollution, more dust and polymetallic dust.

3.1.2 Installation position prompt

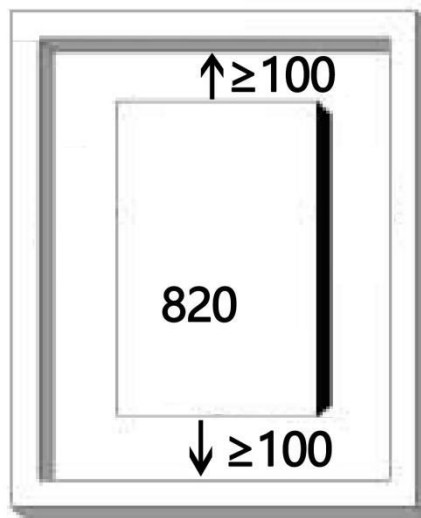

Figure 3-1

Mechanical installation needs to pay attention to the heat dissipation problem. So please note the following points:

- 1) Please install the frequency converter vertically to facilitate the upward heat distribution. But can't be inverted.

- 2) The installation space is as shown in the figure above to ensure the heat dissipation space of the frequency converter. However, please consider the heat dissipation of other devices in the cabinet when layout.
- 3) The mounting bracket must be of non-flammable material.
- 4) For the occasion where dust needs to be sealed, the cooling space in the cabinet must be large enough.

3.1.3 Panel removal and installation

Disassembly: Use the tool to push out the hook bayonet on both sides of the upper cover plate to the inside.

Installation: Please first put the upper bayonet of the upper cover plate into the hole of the lower cover plate first, and then press it down, when the "click" sound is heard.

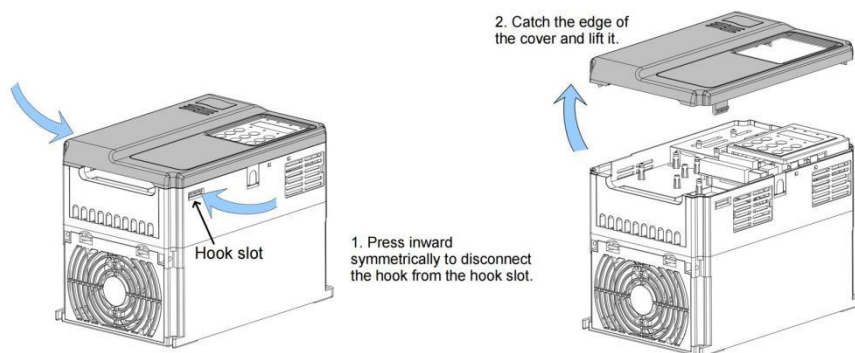

Figure 3-2

3.2 Electrical part installation

3.2.1 Selection guidance of peripheral electrical components (including IP models)

Model.	air switch (MCCB) A	Contactor A	input side Main circuit wire mm ²	outlet side Main loop conductor mm ²	Control loop wire mm ²	ground lead mm ²
FST-820-5R5GT4	32	25	6	6	1	4
FST-820-7R5GT4	40	32	6	6	1	4
FST-820-011GT4	63	40	6	6	1	4
FST-820-015GT4	63	40	6	6	1	4

Connection to the peripheral machines

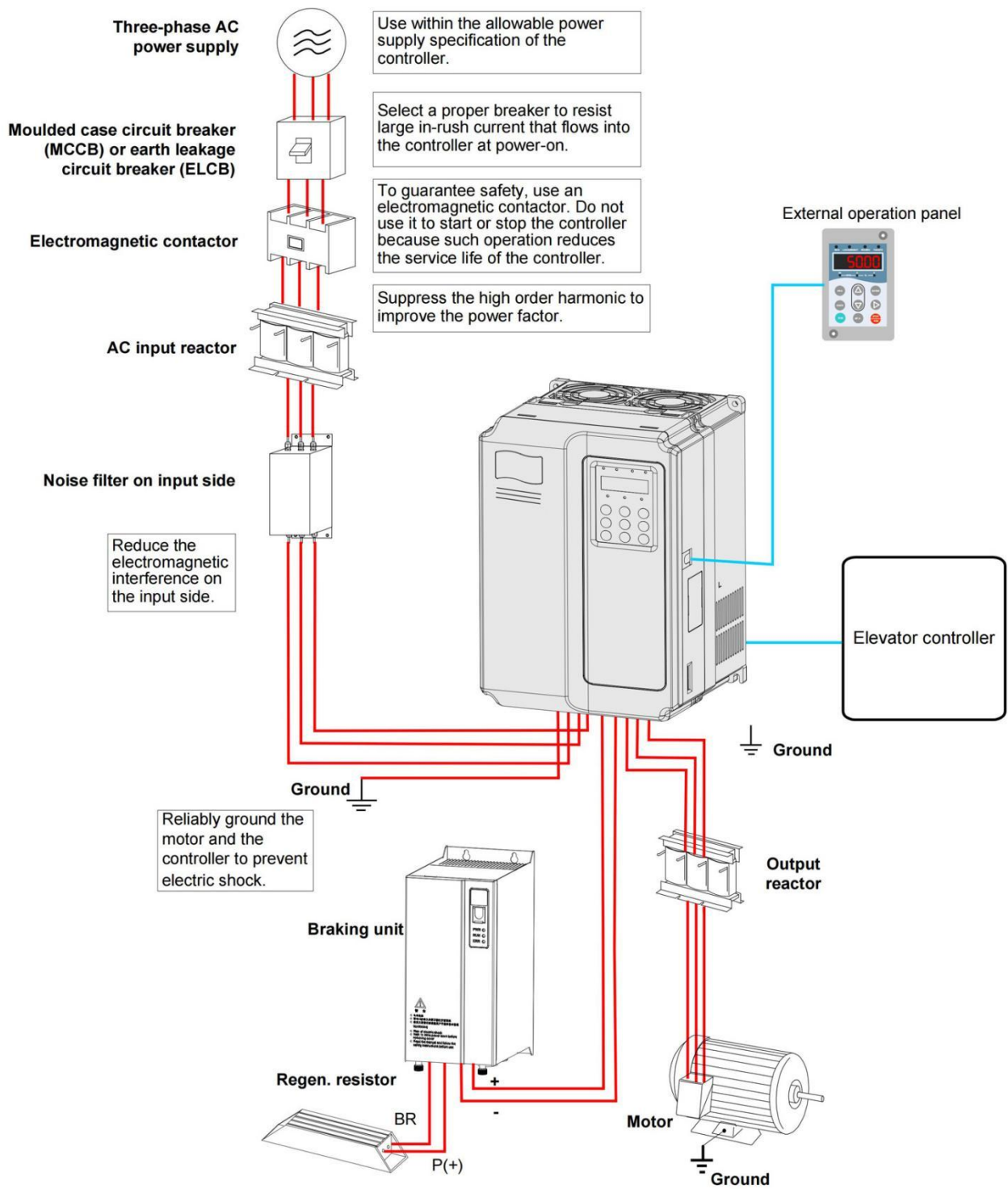

Figure 3-3 Example of a connection to a peripheral machine

- 1) Do not install capacitors or a surge suppressor on the output side of the frequency converter, which will cause the failure of the frequency converter or the damage of the capacitance and surge suppressor.
- 2) Input / output (main circuit) of the frequency converter includes harmonic components that may interfere with the communication equipment of the frequency converter accessories. Therefore, an anti-interference filter is installed to minimize the interference.
- 3) For the details and options of peripheral equipment, refer to the selection manual of peripheral equipment.

3.2.2 Instructions for the use of the peripheral electrical components:

Accessories name	installation site	function declaration
air switch	Front end of the power input loop.	Easy to cut off the frequency converter power supply and provide the frequency converter short-circuit protection. This switch must be selected.
contactor	Between the open frequency converter input side and the frequency converter input side	The frequency converter is powered off for the operation. Frequent power operation or direct start and stop operation through the closing and disconnection of the contactor should be avoided.
AC input reactor	Input side of the frequency converter	1) Increase the power factor on the input side; 2) Effectively eliminate the high-harmonic wave on the input side to effectively protect the rectifier bridge; 3) Eliminate the input current imbalance caused by the power supply imbalance; If the above performance still cannot meet the requirements, select the AC input reactor.
DC reactor	820 Series frequency converter 7.5kW~15kW DC reactor is the standard configuration	1) Increase the power factor on the input side; 2) Effectively eliminate the influence of input high harmonic on frequency converter and effectively protect the rectifier bridge; 3) -Eliminate the input current imbalance caused by power supply imbalance. But it works less than the AC input reactor. DC reactor volume is small, and does not produce pressure drop in the loop, so it is generally recommended to choose DC reactor. Our DC reactor is a standard configuration.
AC output reactor	Between the inverter output side and the motor. Installation is made close to the frequency converter	The output side of the frequency converter generally contains more high-order harmonics. When the distance between the motor and the inverter is far away, because there is a large distribution of capacitance in the line. One of the harmonic may produce resonance in the circuit, which has two effects: 1) Damage the insulation performance of the motor, and it will damage the motor for a long time; 2) Generate a large leakage current, causing the frequent protection of the frequency converter. Generally, the distance between the inverter and the motor is more than 100 meters, so it is recommended to install the output AC reactor.

3.2.3 Electrical wiring



- Make ify the power switch is in OFF. Otherwise, an electric shock accident may occur!
- Route personnel must be professional trainees. Otherwise, it may cause injury to the equipment and the person!
- Grounding must be reliably standardized. Otherwise, there is an electric shock or a fire danger!

- DC bus terminals (+), (-) can not be connected to the brake resistance, otherwise a serious accident may occur!



- Verify that the input power supply of the inverter is consistent with the power supply supplied. Otherwise, damage the frequency converter!
- Verify that the connected motor and the adapted motor of the frequency converter match. Otherwise, it may damage the motor or cause the frequency converter protection!
- Do not connect power to U, V and W terminals. Otherwise, damage the frequency converter!

1、Wiring mode (including IP model)

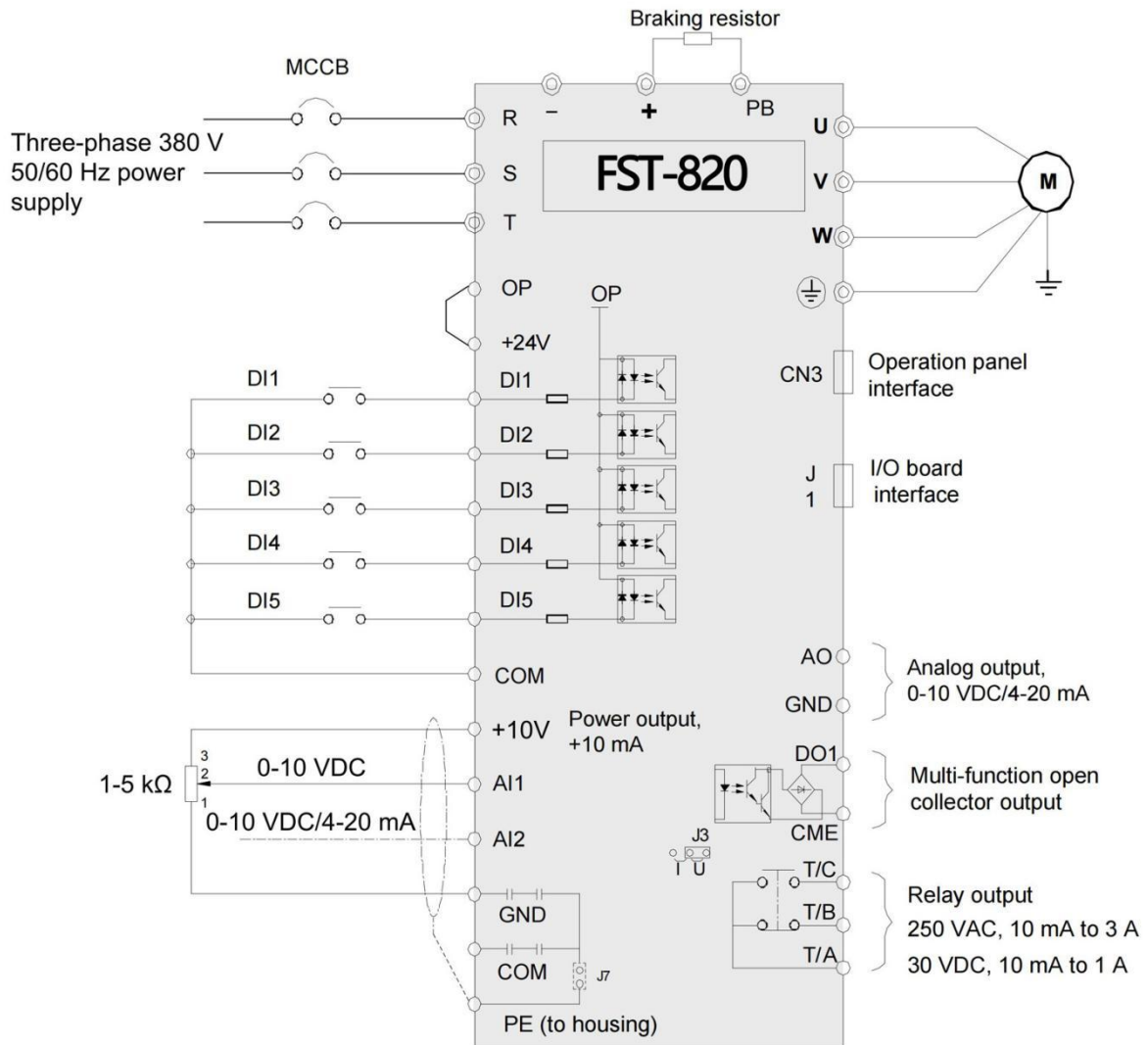

Figure 3-4

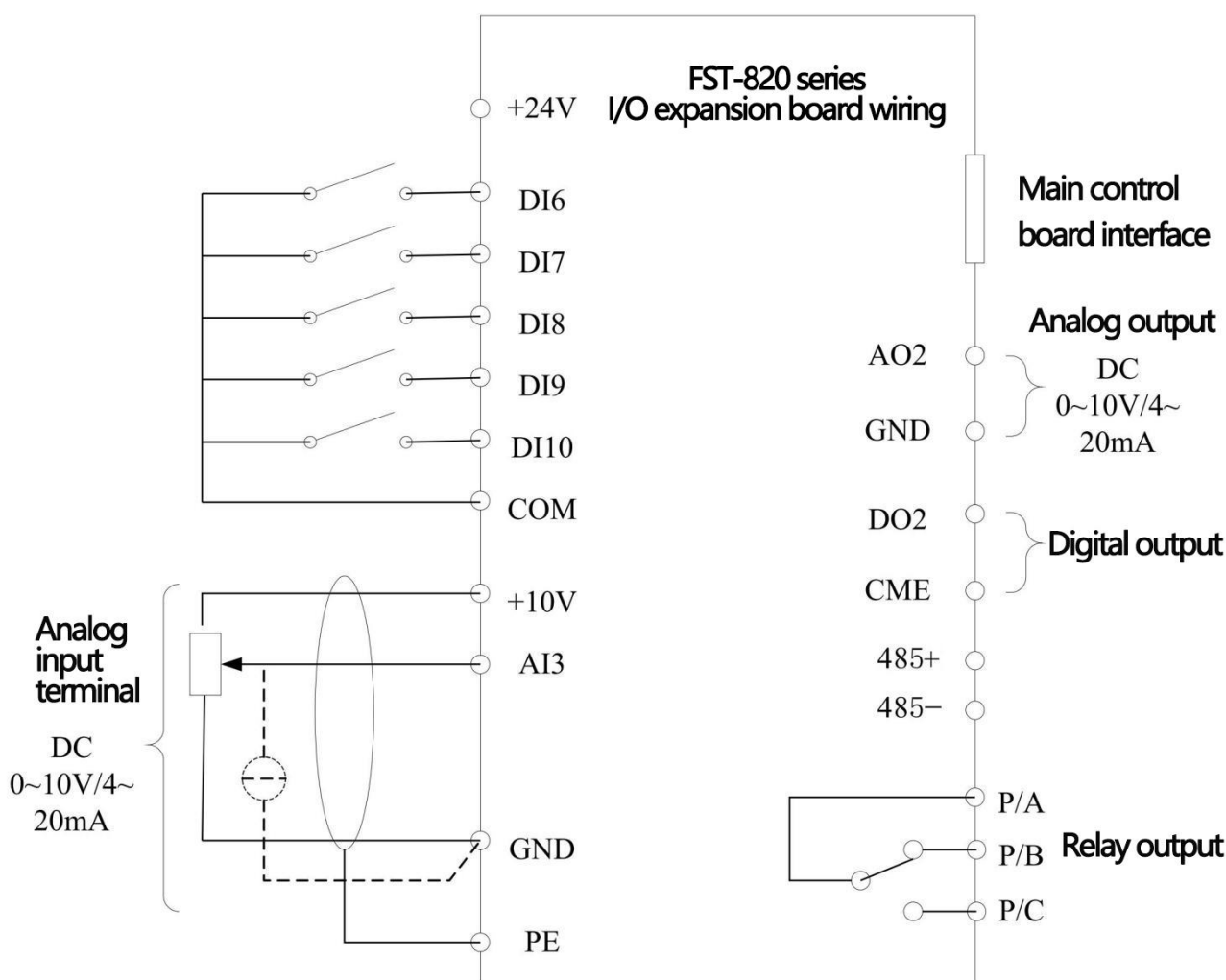

Figure 3-5

2. Main circuit terminals and their wiring

1) Function description of the main loop terminal:

Terminal mark	name	explain
R 、 S 、 T	Three-phase power supply input terminal	An AC 3-phase 380V power supply input terminal
(+)、 (-)	DC bus line plus and minus terminal	Common DC bus input point; connection terminal of external brake unit of frequency converter above 37kW
P(+)、 PB	Brake resistance connection terminal	Brake resistance connection terminals for inverter below 30kw and 30kw
U 、 V 、 W	Frequency converter output terminal	Connect to the three-phase motor
PE	earth terminal	earth terminal

2) Wiring precautions:

A. DC bus line (+) and (-) terminals:

Note that there is still residual voltage on the DC bus (+) and (-) terminals after the power failure. It must be reached before the value is less than 36V.

In order to release the feedback energy received during braking operation, the 820 frequency converter above 37kW needs to connect the external brake unit at the DC bus (+) and (-) terminals, and connect the brake resistance at the P and PB ends of the brake unit. Pay attention to (+), (-) polarity must not be reversed, otherwise lead to damage to the frequency converter or even cause fire. The wiring length between the brake unit and the DC bus terminal (+) and (-) shall not exceed 5 meters, and the wiring length between the brake unit and the brake resistance shall not exceed 10 meters. Twair or tight double line parallel wiring shall be used.

Do not connect the brake resistance directly to the DC bus, which may cause damage to the frequency converter or even fire.

B. The brake resistance terminal (+), and PB:

820 The inverter model with a power below 30kW has a built-in brake unit. In order to release the energy feedback during the brake operation, the brake resistance must be connected at the (+) and PB terminals.

The selection of the brake resistance must refer to the values recommended in Chapter 2, the brake resistance selection table.

The wiring length of the brake resistance shall be less than 5 meters.

The temperature of the brake resistance increases due to the energy release, so attention should be paid to the protection and heat dissipation.

C, U, V, W of output side and inverter:

The inverter output side is connected to the three-phase motor. When the motor steering is opposite to the actual demand, the motor steering can be changed by changing any two of the three lines U, V and W.

The output side of the inverter can not be connected to the capacitor or surge absorber, otherwise the frequency converter will be often protected or even damaged.

Absolthe output side circuit.

The output lines U, V and W of the frequency converter shall be penetrated into the ground metal pipe and arranged separately or vertically led away from the control loop signal line.

When the lead from the motor to the frequency converter is too long, the high-frequency current of the circuit is easy to cause resonance due to the influence of the distribution capacitance

Motor insulation damage or produce a large leakage current to make the frequency converter overcurrent protection. The general length is not more than 100 meters. When this distance is greater, it is recommended to install an AC output reactor.

D, earth terminal:

The grounding terminal of the frequency converter must be well grounded, and the grounding wire must be thick and short. It is recommended to use a special multiple copper core grounding wire with yellow and green above 4mm², and ensure that the grounding resistance is not greater than 5Ω. Grgrounding shall be dedicated. Do not share the ground pole and the power zero line.

3. Control terminal and its wiring:

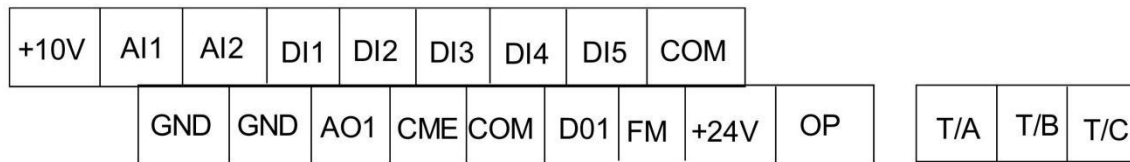

Figure 3-6

1) The terminal layout of the main control board is as follows:

2) FDescription of the control terminal function:

class	Terminal symbol	Terminal name	function declaration
source	+10V-GND	External connection with + 10V power supply	Provide the + 10V power supply to the outside, the maximum output current: 10mA is generally used as the external potentiometer working power supply, the potentiometer resistance value range: 1 k Ω 5k Ω
	+24V-COM	External connection with + 24V power supply	Provide the + 24V external power supply, which is generally used as the digital input terminal working power supply and the external sensor power supply, with the maximum output current: 200mA
	OP	External power supply input terminal	Factory works with a + 24V connection by default When driving the DI1 DI5 with external signals, the OP needs to be connected to an external power supply and disconnected from the + 24V electrical terminal
imitate import	AI1-GND	Simulated input terminal 1	Input voltage range; DCO 10V Input impedance: 100 k Ω
	AI2-GND	Simulated input terminal 2	1. Input range: DC010V / 420mA, as determined by the J3 jumper on the control panel 2. Input impedance; 100k Ω at voltage input and 500Q at current input
Digital input terminal	DI1-COM	Digital input 1	1. Optical coupling and isolation, compatible with bipolar input 2. Input impedance: 3.3k Ω 3. Voltage range at level input: 9V 30V
	DI2-COM	Digital input 2	
	DI3-COM	Digital input 3	
	DI4-COM	Digital input 4	
	DI5-COM	Digital input 5 (High Speed Pulse)	Not only has the DI1-DI4 characteristics, but also as a high-speed pulse input channel
analog output	AO1-GND	Analog output 1	Specification of the voltage or current output output voltage amount that is determined by the J4 jumper on the control board: 0V-10V output flow amount specification: 0mA 2mA

class	Terminal symbol	Terminal name	function declaration
figure output	DO1-CME	Digital output 1	Optical coupling isolation, bipolar open circuit collector electrode type output Output voltage specification: 0V 24V Output current specification: 0mA, 50mA Note: Digital output CME is internally isolated from digital input COM, but CME and COM are external shorted when leaving the factory (DO1 defaults to + 24V drive): When DO1 wants to drive with external power, it must break the external shorting between C O E and COM.
	FM-COM	High speed pulse output	
electrical equipment output	T/A-T/B	Often closed terminal	Contact Drive Capacity: AC: 250V、3A、Cos (p=0.4 DC: 30V、1A
	T/A-T/C	Often start	
assist joggle	J1	Function extension card interface	The 28-core terminal, the industry special card interface
	J2	PG card interface	Special interface for PG card (deleted)
	CN3	External keyboard interface	Outer bow I keyboard, parameter copy unit interface

3) The expansion card terminal layout is as follows:

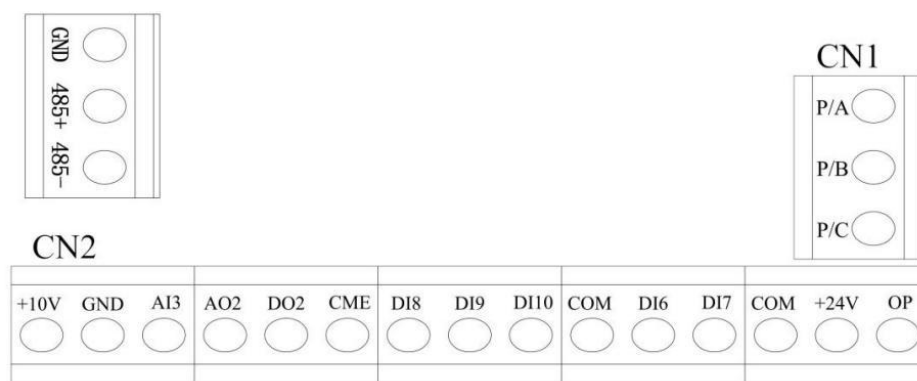

Figure 3-7

3) Extension card terminal function description:

class	Terminal symbol	Terminal name	function declaration
source	+10V-GND	External connection with +10V power supply	Provide + 10V power supply outward, with the maximum output current: 10mA Generally used as the working power supply of external potentiometer, potentiometer resistance range: 1 k Ω -10k Ω
	+24V-COM	External connection with +24V power supply	Provide + 24V power supply outward, generally used as a digital input and output terminal working power supply and external sensor power supply Maximum output current: 200mA
	OP	External power supply access terminal	Factory default with + 24V connection When driving DI6 DI10 with external signals, OP requires electricity with external The source is connected and is disconnected from the + 24V power supply terminal
analog input	AI3-GND	continue to have	continue to have
Functional digital input terminal	DI6COM	Digital input 6	1) Optical coupled isolation, compatible with bipolar input 2) Input impedance: 3.3k Ω 3) Level-time input voltage range: 9V-30V
	DI7COM	Digital input 7	
	DI8COM	Digital input 8	
	DI9COM	Digital input 9	
	DI10-COM	Number input: 10	
analog output	AO2-GND	continue to have	continue to have
numeric output	DO2-CME	Digital output 2	Optical coupling isolation, bipolar open circuit collector output Output voltage range: 0V 24V Output current range: 0mA and 50mA Note: The digital output CME is internally isolated from the digital input COM, and the user must briefly connect the CME to the COM externally. When DO2 wants to drive with external power, CME must be disconnected from COM
relay output	P/A-P/B	Often closed terminal	Contact Drive Capacity: AC250V, 3A, COS<p=0.4 DC 30V, 1A
	P/A-P/C	Often start	

class	Terminal symbol	Terminal name	function declaration
communication	485+	Communication interface terminal	Input and output signal terminals of RS-485 communication
	485-		
Auxiliary interface	JK1	Control board interface	28-core terminal, interface with the control board for 820 series elevator dedicated inverter

5) Description of the control terminal connection:

a. Digital quantity input terminal:

Generally need to use the shielding cable or stranded wire (refer to the peripheral electrical element wiring) wiring, requiring the wiring distance as short as possible, less than 20 meters. If used, connect the shield to the PE terminal near the converter side.

When driven by active mode, necessary filtering measures shall be taken for the crosstalk of power supply. It is recommended to choose the contact point control mode.

There are the 820 series elevator special frequency converter with 10 digital input terminals, divided into 5 main control boards and 5 expansion boards. These two groups can respectively or simultaneously adopt external power supply, internal 24V power supply, high input level action and low input level action, and these flexible combinations greatly facilitate the use of users. Please consult the manufacturer if you have any questions.

b. Digital quantity output terminal:

The DO1 and DO2 can adopt the external or internal power sources, and the output mode can be set to the "NPN" or "PNP" type, respectively.

When the digital output terminal needs to drive the relay, the absorption diodes shall be installed on both sides of the relay coil. Otherwise, it is easy to cause the DC 24V power supply or the output circuit damage.

Note: Be sure to install the polarity of the absorption diode properly. The following diagram shows. Otherwise, when the digital output terminal has output, the DC 24V power supply and output circuit will be damaged.

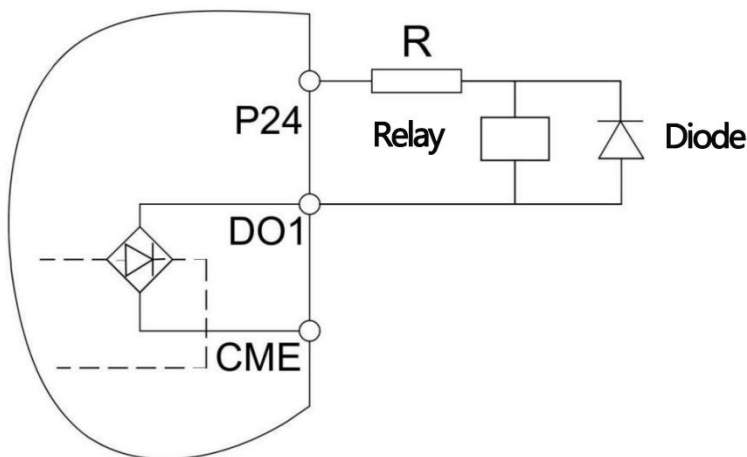

Figure 3-8 Schematic diagram of the digital output terminal

c. Analog input terminal:

Because the weak analog signal is particularly vulnerable to external interference, so it is generally necessary to use

the shielding cable, and the wiring distance is not more than 20 meters as short as possible, and the shielding layer is reliably and well grounded close to the end of the frequency converter, as shown in Figure 3-9. In some cases where the analog signal is seriously disturbed, a filter capacitor or ferrite magnetic core should be added to the analog signal source side, as shown in Figure 3-10:

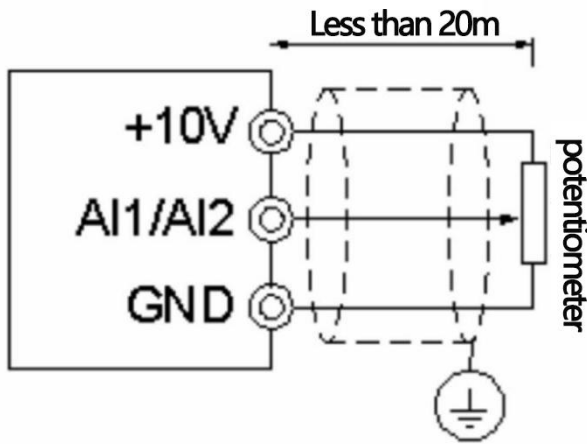

Figure 3-9

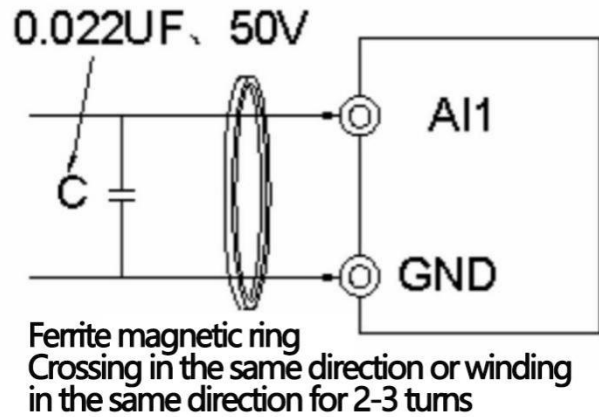

Figure 3-10

3.2.4 Wiring and description of a PG card for elevator special transfer encoder

1. MCTC-PG-A (equipped with open-circuit collector output and push-pull output increment encode used for asynchronous machine)

1) qualification

	function	response speed	output impedance	output	Frequency range
+ 15V, COM	The Encoder power supply is provided	---	About 300 ohms	300mA	—
PGA, PGB	Encoder signal access	0 ~80kHz	one	one	one
OUT-A OUT-B	Spectrum signal output	0—80kHz	About 30 ohm	100mA	162 (even number)

2) PG card terminal and dial code description

There are 9 user terminals for the PG cards, as shown in Figure 3-11. Among them, + 15PG and COM are the operating power output, PGA and PGB are the encoder signal input terminals, OUT-A, OUT-B, COM is the frequency signal output terminal; PE is the shielding wire terminal (no PE is connected inside the PG card, and the user must connect when using).

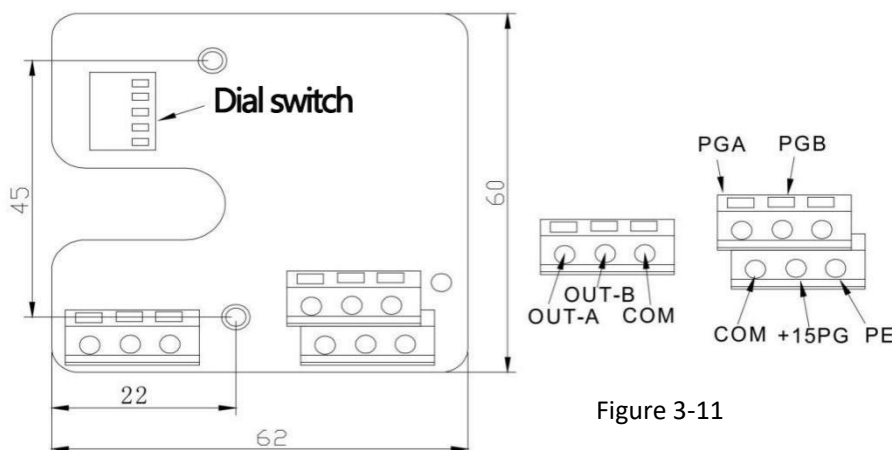

Figure 3-11

The frequency division coefficient is determined by the dial switch on the PG card. The dial switch has a total of 5 bits, according to the 2 decimal number expressed and multiplied by 2 to determine the frequency division coefficient. The dial switch has the binary low marked "1" and the binary low marked "5" as the binary high. When the code is dialed to ON, the bit is valid, indicating "1" and "0". The comparison of dialing switch position and frequency division coefficient is shown in the following table:

decimal system	binary number	Frequency ratio coefficient
0	0	No frequency separation signal
1	1	No frequency separation signal
2	10	2 * 2 The frequency
...
I	...	1 * 2 The frequency
31	11111	31 * 2 The frequency

3) PG card wiring

The 820 series elevator special inverter is standard equipped with PG card with frequency distribution output, and its wiring must pay attention to the following points:

- A. PG cables must be arranged separately from the cable routing of the control circuit and the power circuit, and close and parallel wiring is strictly prohibited.
- B. The wiring of PG must be a screened line, which is connected to the PE terminal close to the frequency converter.(To avoid interference, only one end can be ground)
- C. PG cable must be wired separately, and the metal pipe shell shall be reliably grounded.

The connection of the PG card is shown in Figure 3-12 below:

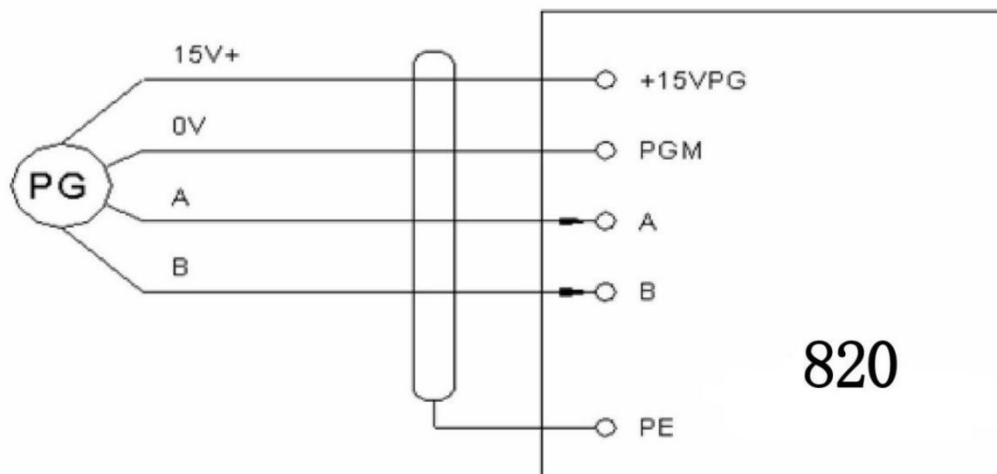

Figure 3-12 MCTC-PG-A

2. MCTC-PG-B (equipped with U, V, and W type encode used for asynchronous machine)

1) Technical indicators:

	function	response speed	output impedance	output	Frequency range
VCC, GND	The Encoder power supply is provided	—	About 300 ohms	300mA	—
A+, B+, A-, B-, U+, V+, W+, U-, V-, W-	Encoder signal access	0kHz ~ 80kHz	—	—	—
OUT-A,OUT -B,COM	Spectrum signal output	0kHz ~ 80kHz	About 30 ohm	100mA	1

2) PG card terminal and dial code description

There are 15 user terminals for PG card, see Figure 3-11. VCC and GND are the working power output; A +, B +, A-, B-, U +, V +, W +, W +, U-, V-, W-are the encoder signal input terminals; OUT-A, OUT-B and COM are frequency division signal output terminals;

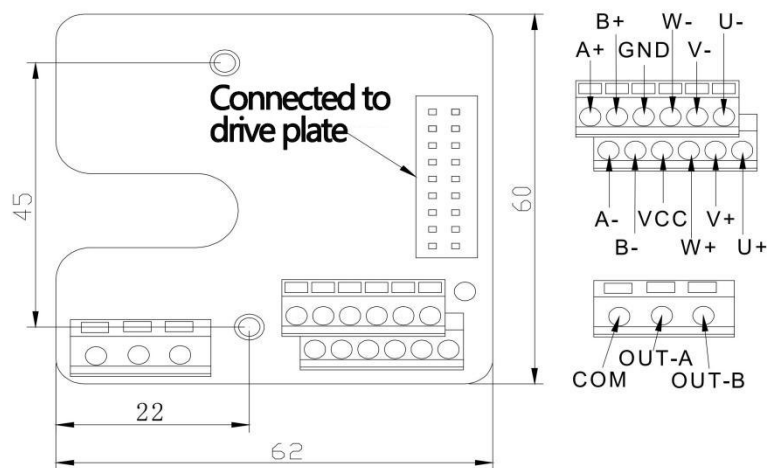

Figure 3-13 MCTC-PG-B Synchronizer PG Card (U, V, W-type encoder or asynchronous machine long-line output encoder)

4) MCTC-PG-B Wiring instructions:

A) Cable routing of PG must be arranged separately from the cable routing of the control circuit and the power circuit, and close and parallel wiring is strictly prohibited.

b) PG cable wiring must be pierced separately, and the metal pipe shell must be reliably grounded.

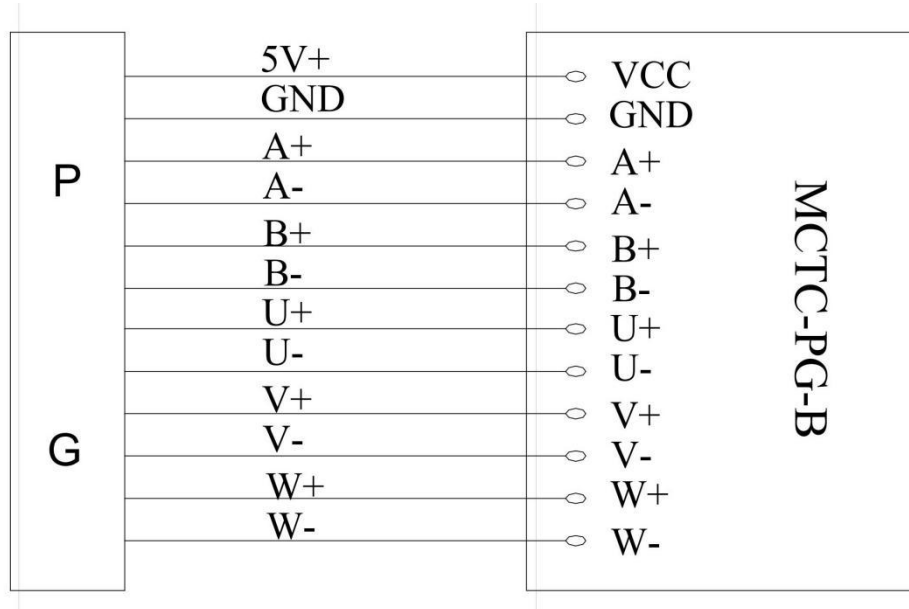

Figure 3-14 MCTC-PG-B PG card wiring diagram

3.3 Handling of E M C problems

3.3.1 Age ring of the harmonics

1) The high harmonic contained in the power supply itself mainly has a great impact on the rectifier part, which is easy to cause the heating after the long-term work and then cause the working point drift and damage of the rectifier bridge. Therefore, in some places with poor power grid quality, it is suggested to solve the harmonic problem of the input power supply by installing a filter or an AC input reactor or installing a DC reactor on the inverter DC bus between the power supply and the frequency converter, so as to protect the frequency converter.

2) Due to the high-harmonic wave on the output side of the frequency converter, if the capacitance and surge inhibitor are installed to improve the power factor, it may cause circuit current shock and equipment damage. Therefore, the output side can not be equipped with a capacitor or surge suppression equipment.

3.3.2 Electromagnetic interference and treatment

There are two kinds of electromagnetic interference: one is the interference of the peripheral electromagnetic noise to the inverter, causing the misaction of the frequency converter itself. This interference generally has less impact, because the frequency converter has been designed for this part of the interference internally. Its own anti-interference ability is relatively strong. Another interference is the impact of the frequency converter on the surrounding equipment. Here are two solutions to the problems:

1) Treatment method of interference of surrounding electromagnetic equipment to frequency converter

The general reason for the electromagnetic impact on the frequency converter is that a large number of relays, contactors or electromagnetic brakes are installed near the frequency converter. When the inverter is disturbed and misoperated, the following methods are used:

A) Install a surge suppressor to the jamming device.

Install b) Install the signal input of the frequency converter.

2) Treatment method of noise generation of frequency converter interfering with surrounding equipment

The premise for solving this problem is that:

A) The grounding wire of the inverter and other electrical products shall be well grounded, and the grounding resistance shall not be greater than 5 ohms.

b) The power supply line of the frequency converter should not be arranged parallel to the control line as far as possible, and vertically when possible.

c) For places with high interference requirements, the power line from the frequency converter to the motor should be shielded cable and the shielding layer should be reliably grounded.

The d) twisted pair shielding control wire is recommended for disturbed equipment and the shielding is reliably grounded.

This part of the noise is divided into two kinds: one is the frequency converter itself amplitude shot, the other is through the frequency converter to the motor lead amplitude shot. These two kinds of amplitude radiation make the lead surface of the peripheral electrical equipment to electromagnetic and electrostatic induction.

A) The instrument, receiver and sensor for measurement are generally weak. If it is close to frequency converter or in the same control cabinet, it is recommended to adopt the following methods to solve: keep away from interference source; do not bundle signal line parallel and power line; install linear filter or radio noise filter on the input and output side of frequency converter.

b) When the disturbed equipment and the frequency converter use the same power supply, if the above method cannot eliminate the interference, the linear filter or radio noise filter should be installed between the frequency converter and the power supply.

c) The peripheral equipment is grounded separately, which can eliminate the interference caused by the leakage current of the grounding wire of the frequency converter in the common ground.

3.3.3 Current measurement and treatment

There are two forms of leakage current: the leakage current to the ground and the leakage current between lines.

1) Factors affecting the ground drain current and their solutions:

There is a distributed capacitance between the conductor and the earth, the greater the leakage current; effectively reduce the distance between the frequency converter and the motor to reduce the distributed capacitance. The greater the carrier frequency, the greater the leakage current. The carrier frequency can be reduced to reduce the leakage current. However, reducing the carrier frequency causes increase motor noise, please note. Adding the reactor is also an effective way to solve the leakage current.

2) The leakage current will increase with the increase of the circuit current, so the leakage current is large when the motor power is large.

3) Factors and solutions of wire leakage current:

There is a distributed capacitance between the output wiring of the frequency converter. If the current passing through the line contains high harmonics, it may produce resonance and produce a leakage current. A thermal relay may be mistaken.

The solution is to reduce the carrier frequency or install the output reactors. It is recommended to install no heat relay before the motor when using frequency converter, and use the electronic overcurrent protection function of frequency converter.

Chapter IV: Operation and commissioning

This chapter details the keyboard operation of the 820 series elevator special inverter operation display panel and the setting of the function code.

4.1 Term ology of FST- 820 series frequency converter

The basic terms of 820 series frequency converter include four categories: operation mode, control mode, operation mode and working status.

4.1.1 Operation mode

Operation mode means in which way the frequency converter receives running commands and speed instructions.820 The frequency converter can choose only choose one of the operation modes.

Operation panel control: inverter output control with operation panel RUN and STOP keys.

Terminal command control: The running command and the running speed are controlled by the multi-function input terminal input signal.

Communication command control: running command and running speed are given by communication mode.

4.1.2 Control mode

The 820 frequency converter provides three control modes:

No Speed Sensor vector control (SVC)

Speed sensor vector control (VC)

V/F control

4.1.3 Operation mode

Self-tuning mode operation: The 820 elevator dedicated inverter provides the motor self-learning mode with and without load, see the parameters F1-11 for details.

Normal Mode operation: Operation in the operation panel control state and simulation quantity The operation in a given state is called normal mode operation.

Multi-speed operation: when the operation speed is controlled by multi-speed speed combination, it is called multi-speed operation.

The frequency converter can only operate in one mode at any time.

4.1.4 Working status

There are four states of the inverter, namely: shutdown state, programming state, operation state and fault alarm state.

stopped state:

Stop up or after the operation command is over, the converter is in standby until the operation command is accepted. When the run indicator goes off, the LED display flashes overall, and the different parameters can be displayed by>> keys.

Programming status:

Through the operation panel of the inverter parameters to see and set, the state of this time is the programming state.

Operation status (while the elevator is in operation):

When the inverter is in the operation state, the operation indicator light is on. The LED is non-flashing state.

Fault alarm status:

The fault alarm state is the state when the fault and the fault code is displayed.

4.2 Introduction of the operation and display interface

The operating keyboard with LED display is the standard configuration of 820 series frequency converter. Users can modify the functional parameters of 820 series frequency converter, monitor the working state of frequency converter and control the frequency converter (start and stop) through the keyboard.

Its shape and functional area are shown in Figure 4-1:

4.2.1 Function lamp indicator description:

When the RUN light is on, the frequency converter is in operation.

LOCAUREMOT Keyboard Operation and Remote Operation (terminal) indicator light, the light is lit in the remote operation control state.

The FWD / REV elevator up and down indicator light means that the FWD command is valid and the elevator is up; the lights out means that the REV command is valid and the elevator is down. The indicator is invalid when shutdown.

TUNE / TC tuning indicator light indicating the tuning state.

4.2.2 Digital display area:

The 5-bit LED display displays various monitoring data such as set frequency and output frequency and alarm code

4.2.3 Description of the unit indicator light:

Hz	Frequency unit	A	unit of current
V	voltage unit	RPM	Speed unit
%	percentage		

4.2.4 Keypad key description:

key	name	function
PRG	Programming key	Level 1 menu entry and exit, and the shortcut parameters are deleted
QUICK	keyboard shortcuts	Enter or exit the primary menu of the shortcut menu. See the QUICK operating
RUN	Run the key	In the keyboard operation mode, it is used to start the operation
▲	Increased key	Increment of the data or function code
▼	Degradation key	Declining number of the data or function codes



Figure 4-1, Operation

key	name	function
	The displacement key	In the shutdown state and in the running state, you can cycle to select the display parameter of the LED: when you modify the parameter, you can select the modification bit of the parameter
MF.K	Multi-function	Display and extinction of fault information
ENTER	Confirm the key	Enter the menu screen step by step and confirm the setting parameters
STOP/RES	Stop the reset key	Press this key to stop operation operation and reset operation during fault alarm status

4.3 Description of function code reading and operation method

4.3.1 Operation process of the tertiary menu:

820 The operating panel parameter setting method of the frequency converter adopts the three-level menu structure form, which can easily query and quickly modify the function code and parameters.

The three-level menu is: function parameter group (level 1 menu) -function code (level 2 menu) -function code setting value (level 3 menu). The operation procedure is shown in Figure 4-2.

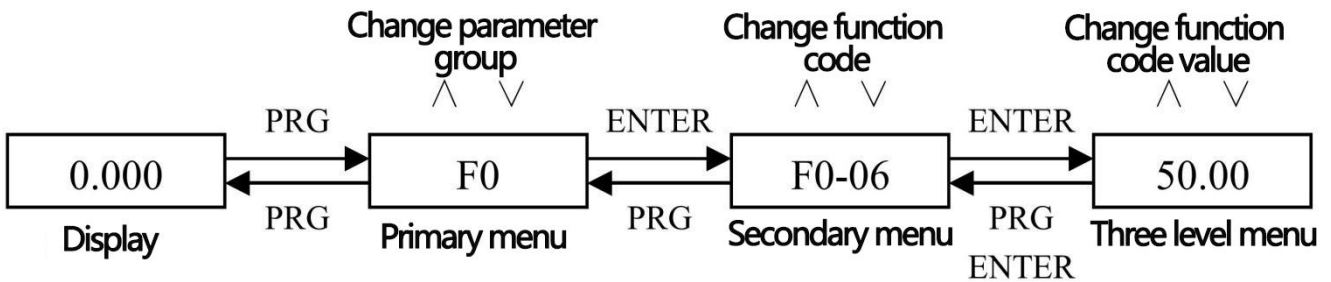

Figure 4-2 Flow chart of the tertiary menu operation

Description: During the tertiary menu operation, press the PRG key or ENTER key to return to the secondary menu. The difference between the two is: press ENTER key to save the set parameters and then return to the secondary menu, and automatically transfer to the next function code; press PRG key to directly return to the secondary menu, do not store the parameters, and stay in the current function code.

Example: An example setting the function code F0-05 from 50.00Hz to 15.00Hz (bold).

Shutdown display

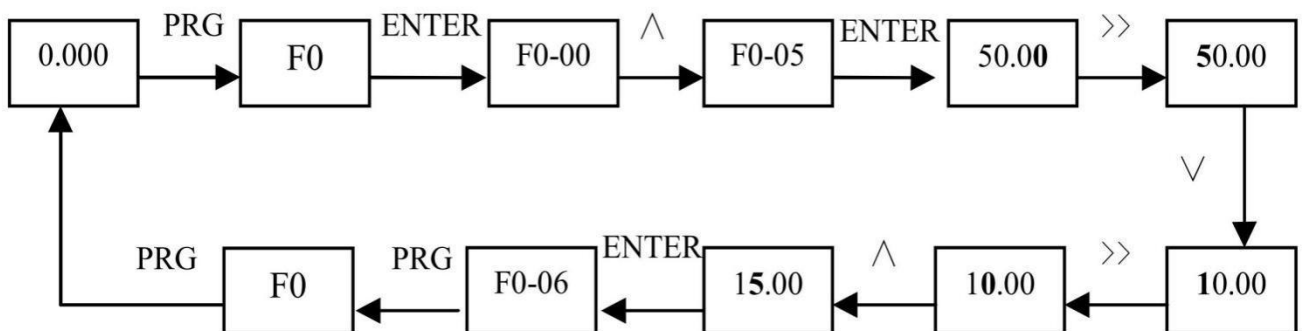

Figure 4-3 Example of a parameter editing operation

In the three-level menu state, if the parameter does not flashing, the function code cannot be modified. The

possible reasons are:

- 1) This function code is a non-modifiable parameter. Such as the actual detection parameters, operation record parameters, etc.
- 2) The function code can not be modified in the running state, and can only be modified after shutdown.

4.3.2 Operation method of switching state display parameters by shift key:

Example of display switching by shift key>> status parameters:

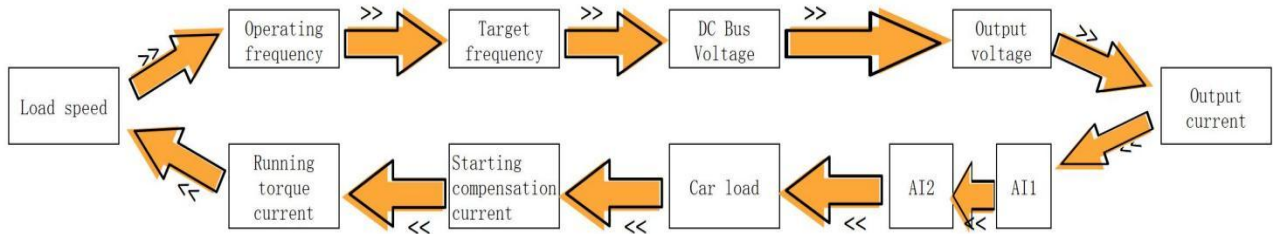

Figure 4-4 Display and switching diagram of status parameters

820 The converter can be displayed by LED digital tube in shutdown or running state with multiple state parameters. The specific display parameters can be selected by the function code F8-01, (running parameter) F8-02 (shutdown parameter) according to the binary bit. It can be switched successively by pressing the shift key to display the status parameters in the shutdown or running state in circulation.

In the shutdown state, 8 shutdown state parameters can be used by the key cycle switch display, as follows: target line speed, target frequency, DC bus voltage, AI1, AI2, car load (%), etc. Users can select the value to be displayed through the F8-02 function code by bit (conversion bit binary), and press the shift key to switch in sequence and display the selected parameters in a loop.

In operation, 15 operating state parameters: operating frequency, load speed, target frequency, DC bus voltage, output voltage, output current, AI1, AI2, car load (%), start compensation current (%), running torque current (%) is selected by the function code F8-01 press (conversion bit binary), press the shift key can switch sequentially, cycle display the selected parameters.

4.3.3 Fault information reading:

When the inverter fails, the fault information code is displayed on the panel. Through the fault code, easy to judge the cause of the fault, as soon as possible troubleshooting.

The frequency converter can save the last three fault codes, and record the frequency, current, bus voltage, digital input terminal status and digital output terminal status of the latest failure. The schematic diagram is as follows:

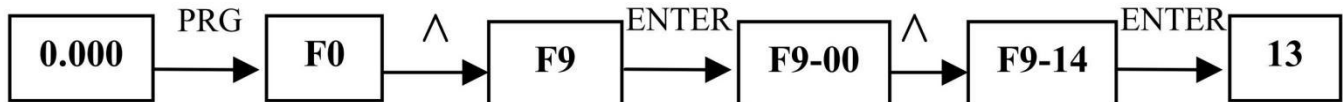

Shutdown display

Figure 4-5 Viewing the fault information

4.3.4 Monitoring of digital input terminal status,

Monitor the digital input terminal status when running, see Chapter 6 F8-00 parameters.

4.4 Operation mode of the shortcut menu

820 Frequenverter shortcut menu is mainly set to facilitate users to see and modify commonly used functional

parameters. The parameters in the shortcut menu are displayed as uF3-02 ", which represents the functional parameter F3-02. Modifying the parameters in the shortcut menu is the same effect as modifying the corresponding parameters in the normal state.

The shortcut menu can add up to 16 functional parameters. If the 16 parameters are full, then display "FULL". If the entry menu shows "NULL", then indicate that the shortcut menu is empty. Initially, 16 common parameters have been stored in the shortcut menu for easy user use.

F0-00: Control mode	F3-00: Startup frequency
F0-01: Command selection	F3-01: Startup frequency retention time
F0-02: Speed selection	F4-13: Multi-segment speed filtering time
F1-11: Selection of motor tuning	F8-00: Terminal status display
F2-00: proportion of 1 coefficient	F8-03: Load speed display
F2-01: integral 1 time	F9-16: Last fault
F2-03: proportion 2 coefficient	FA-00: PG pulse number
F2-04: integral 2 time	FC-00: Command abnormal action selection

Users can edit it according to their own needs.

4.4.1 Parparameters of unhappy menu:

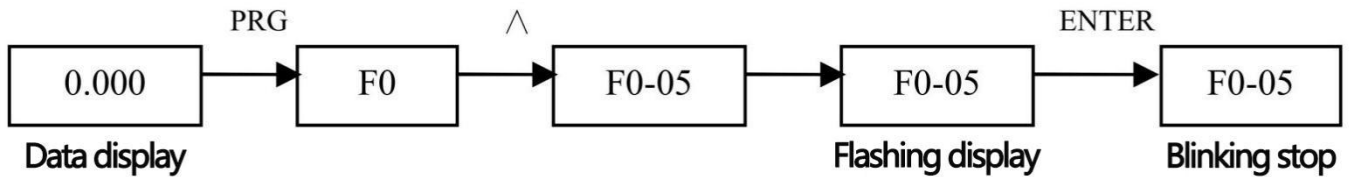

Figure 4-6 Establishment of the shortcut menu

Description: Press QUICK under the programming secondary menu to flash the display content, prompt whether to save the parameter in the shortcut menu, press ENTER to confirm that the display content stops flashing and the operation is completed; press PRG to cancel, the display content stops flashing, and then the operation is to cancel.

4.4.2 Call out and modify parameters in the unhappy menu

Example: Call out the parameters F0-00, F1-11. F4-13, and F8-03 in the shortcut menu:

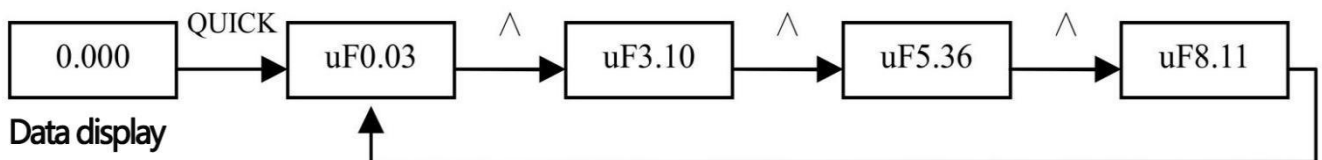

Figure 4-7 Exit of the shortcut menu

Modification: Under the shutdown or running display interface, press QUICK key to enter the shortcut menu, use UP / DOWN key to select different shortcut parameters, and then press ENTER key to enter the next menu, then the shortcut parameter modification method and the same three menu parameters of the ordinary menu. To return the upper display, press QUICK and the modified parameters are not stored.

4.4.3 Delete of the shortcut menu parameters

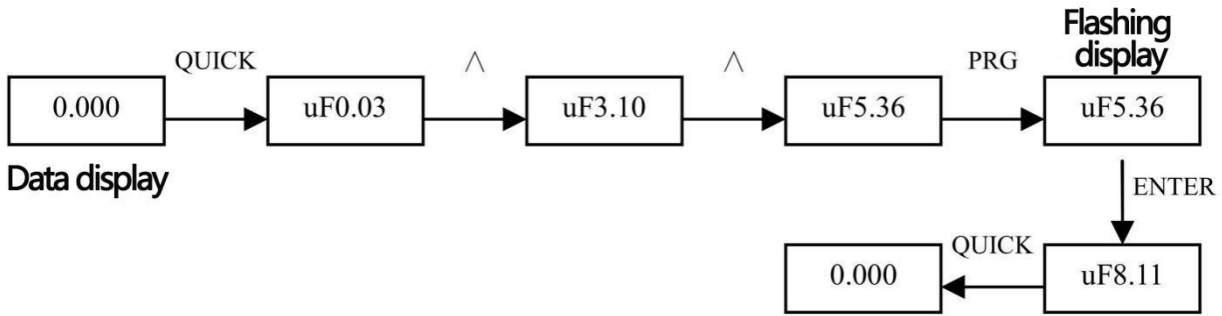

Figure 4-8 Delete of the shortcut menu

If you have the following parameters included in the shortcut menu: F0-00. F1-11. F4-13 and F8-03, if you want to eliminate F4-13 from the shortcut menu, then operate as follows.

Description: Press PRG key under the shortcut menu to display the flashing, prompt whether to delete the parameter, press ENTER key to confirm, display the stop flashing, and the delete operation is completed. If you press QUICK key, display the stop flashing, and cancel the delete operation. If the last shortcut parameter, null, indicating that the shortcut parameter is empty.

4.5 Password setting

For more effective parameter protection, the frequency converter provides password protection.

The following diagram shows the process of changing the password to 12345.

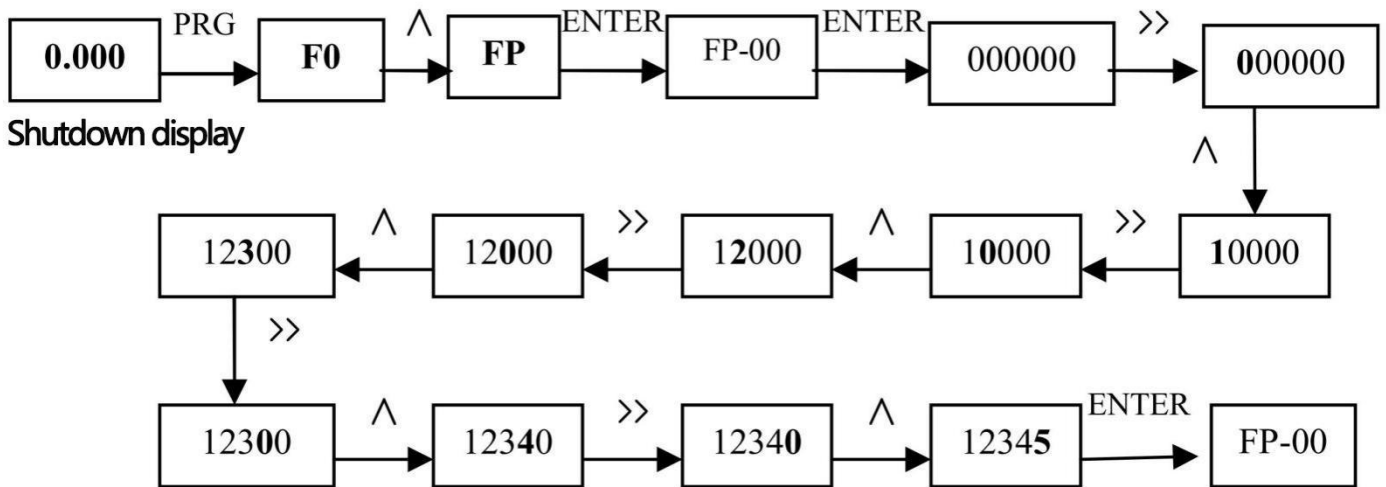

Figure 4-9 Password setting process

After the user password is set (i. e., the parameter of the user password FP-00 is not 0), when the user presses the PRG key to enter the function code editing state, the system will first enter the user password verification state, displayed as "one-", and the operator must correctly enter the user password, otherwise it cannot enter. For the manufacturer to set the parameter area, you also need to correctly enter the manufacturer password before entering.(Remind the user not to try to modify the parameters set by the manufacturer. If the parameters are not set properly, it will easily lead to abnormal work or even damage of the frequency converter.)

When the password protection is not locked state, the user password can be modified at any time. The user password is subject to the last input value.

If you want to cancel the password protection function, only enter by password, and set FP-00 to 0; or then be password protected if FP-00 is not 0.

4.6 Automatic tuning of the motor parameters

Select the vector control operation mode, the motor nameplate parameters must be accurately input before the inverter operation. The 820 inverter matches the standard motor parameters according to the nameplate parameters; the vector control mode is highly dependent on the motor parameters. To obtain good control performance, the accurate parameters of the controlled motor must be obtained. See Chapter 6 F1-11 parameter description and Chapter 7 application commissioning description.

Chapter V: Functional Parameter Table

This chapter details all the functions and related information of the frequency converter for inquiry.

5.1 Functional Parameter Table

The functional parameters of the 820 series frequency converter are grouped by functions, with 15 groups of F0 F9, FA FF and FP. Each functional group includes several functional codes. The function code adopts the three-level menu. The word FX-XX means the "XX" function code in the function table, such as "F9-08" is the No.8 function code of the F9 function.

In order to facilitate the setting of the function code, when using the operation panel, the function group number corresponds to the first-level menu, the function code number corresponds to the second-level menu, and the function code parameters correspond to the three-level menu.

Description of the menu

Column 1: Function Code: Number of function parameter group and parameters; Column 2 Name: full name for function parameter; Column 3: Set range for function parameter, displayed on operation panel LCD LCD monitor; Column 4: Min Unit: minimum unit for function parameter; Column 5: Factory SetPoint: original factory setting for function parameter; Column 6: Change: Change attribute for function parameter (i. e. whether to change and change conditions), described as follows:

"☆": Indicates that the setting value of this parameter can be modified in the frequency converter, shutdown and running state;

"★": indicates that the setting value of this parameter cannot be modified when the frequency converter is in the running state;

"•": indicates that the value of this parameter is actual detection and recorded and cannot be modified;

(The frequency converter has made automatic inspection constraints on the modified properties of various parameters to help users avoid misoperation)

The LCD Display in the table is only valid when using LCD His panel.

The Factory SetPoint indicates that the function code parameters are refreshed when restoring the factory parameters are performed; but the actual detected parameter values or recorded values will not be refreshed.

In order to more effectively, the frequency converter provides password protection for the function code.

5.2, Features Table

5.2.1 Group of function tables

After pressing the PRG key, press the UP / DOWN key. The detailed list is as follows:

F0 —— Basic Features	F8 —— Keyboard with Display
F1 —— motor parameters	F9 —— Fault and Protection
F2 —— vector control parameters	The FA —— PG parameters
F3 —— start-stop control parameters	The FB —— communication parameters
The F4 —— input terminal is used	The FC —— -specific enhancements

The F5 —— output terminal	FF —— Factory Parameters
F6 —— speed parameters	The FP —— User Password
F7 —— curve parameters	

5.2.2. Function schedule:

FC	name	description	Minimum unit	Factory value	Change
F0 —— Basic Features					
F0-00	control method	0: No speed sensor for vector control (SVC) 1: Speed sensor vector control (VC) 2: V / F control	1	1	★
F0-01	Command selection	0: Operation panel running command channel (LED out); 1: Terminal running command channel (LED bright); 2: Communication control (optional special card)	1	1	★
F0-02	Speed selection	0: Digital setting 1: Multi-section speed 1 2: AI1 3: AI2 4: Communication setting (optional special card)	1	1	★
F0-03	Number setting frequency	0.00 Maximum frequency	0.01Hz	00.00Hz	☆
F0-04	Running direction	0: Consisame direction 1: opposite direction	1	0	★
F0-05	maximun-frequency	10.00Hz~90.00Hz	0.01Hz	50.00Hz	★
F0-06	carrier frequency	0.5kHz ~16.0kHz	0.1kHz	Model determination	☆
F0-07	Carrier frequency adjustment selection	0: Fixed PWM, the load frequency temperature adjustment is invalid 1: Random PWM, the load frequency temperature adjustment is invalid 2: Fixed PWM, the carrier temperature adjustment is effective 3: Random PWM, and the carrier temperature adjustment is effective	1	2	☆

FC	name	description	Minimum unit	Factory value	Change
F1 —— motor parameters					
F1-00	Encoder type selection	0: SIN/COS 1: UVW	1	1	★
F1-01	power rating	0.4kW~1000.0kW	0.1 kW	Model determination	★
F1-02	rated voltage	0 ~440V	1V	380	★
F1-03	rated current	0.00 ~655.35A	0.01A	Model determination	★
F1-04	rated frequency	The highest frequency of 0 virus	0.01Hz	50.00Hz	★
F1-05	rated speed	0~30000rpm	1rpm	1460rpm	★
F1-06	stator resistance	0.001 Ω -65.535 Ω	0.001 Ω	Model determination	☆
F1-07	rotor resistance	0.001 Ω -65.535 Ω	0.001 Ω	Model determination	☆
F1-08	Leakage resistance	0.01mH ~655.35mH	0.01mH	Model determination	☆
F1-09	Mutual resistance	0.1mH ~6553.5mH	0.1mH	Model determination	☆
F1-10	no-load current	0.01A-650.00A	0.01A	Model determination	☆
F1-11	Motor tuning selection	0: No operation 1: Static tuning 2: Dynamic tuning	1	0	★
F2 —— vector control parameters					
F2-00	The elring proportional coefficient 1	0-100	1	35	☆
F2-01	The velocity loop integral time 1	0.01S ~10.00S	0.01s	0.60s	☆
F2-02	Switch frequency 1	0.00-F2-05	0.01Hz	2.00Hz	☆

FC	name	description	Minimum unit	Factory value	Change
F2-03	The elring proportional coefficient 2	0—100	1	30	☆
F2-04	The velocity loop integral time 2	0.01S ~ 10.00S	0.01s	0.80	☆
F2-05	Switch frequency 2	F2-02 maximum frequency	0.01Hz	5.00Hz	☆
F2-06	Current ring proportional gain	10-300	1	60	☆
F2-07	Current-loop integral gain	10-300	1	30	☆
F2-08	Cycle upper limit	0.0% ~ 200.0%	0.1%	150.0%	☆
F3 — start/stop control parameters					
F3-00	Start frequency	0.00Hz-10.00Hz	0.01Hz	0.00Hz	☆
F3-01	The torque output is delayed	0.00s ~ 10.00s	0.01s	0.20s	★
F3-02	Hold the lock and open the delay	0.00s ~ 10.00s	0.01s	0.10s	★
F3-03	Zero speed delay	0.00s ~ 10.00s	0.01s	0.30s	★
F3-04	start time	0.00s ~ 10.00s	0.1s	0.0s	★
F3-05	Startup frequency retention time	0.00s ~ 10.00s	0.1s	0.0s	★
F3-06	Lock release delay	0.00s ~ 10.00s	0.01s	0.20s	★
F3-07	Parking zero speed delay	0.00s—10.00s	0.01s	0.30s	★
F3-08	Run the contactor release delay	0.00s—10.00s	0.01s	0.00s	★
F3-09	Start the pretorque setting selection	0: No pre-torque 1: DI setting 2: AI1 setting 3: AI2 setting 4: Use the pre-torque initial offset 5: No weighing compensation	1	0	★

FC	name	description	Minimum unit	Factory value	Change
F3-10	Pre-torque offset	0.0% ~ 100.0%	0.1%	48.0	☆
F3-11	Pre-torque gain	0.00-1.50	0.01	0.60	★
F3-12	Pre-torque initial offset	-100.0% ~ 100.0%	0.1%	10.0%	★
F3-13	DI weighing signal 1	0% ~ 100.0%	0.1%	10.0%	★
F3-14	DI weighing signal 2	0% ~ 100.0%	0.1%	30.0%	★
F3-15	DI weighing signal 3	0% ~ 100.0%	0.1%	70.0%	★
F3-16	DI weighing signal 4	0% ~ 100.0%	0.1%	90.0%	★
F3-17	Weigh-in analog volume input filter time	0.00s ~ 1.00s	0.01s	0.10s	☆
F3-18	We-in analog empty load	0.00V-10.00V	0.01V	0.00V	☆
F3-19	Weighing analog full load corresponding input	0.00V ~ 10.00V	0.01V	10.00V	☆
F3-20	Simulation volume was weighed for self-learning	0-100	1	0	☆
F3-21	Analog volume was weighed by self-learning selection	0: No operation 1: Self-learning allows you	1	0	☆
F3-22	Pre-torque direction is reversed	0: The direction remains unchanged 1: Directions are reversed	1	0	☆
F4 — Input terminal is used					
F4-00	DI filtering time	0.000s ~ 0.200s	0.001	0.020s	☆
F4-01	DI1 terminal function selection	0: No function 1: Forward transfer order (FWD, uplink)	1	1	★
F4-02	DI2 terminal function selection	2: Reverse command (REV, Downlink)	1	2	★
F4-03	DI3 terminal functional selection	3: Multistage speed terminal 1 4: Multistage speed terminal 2	1	3	★

FC	name	description	Minimum unit	Factory value	Change
F4-04	DI4 terminal function selection	5: Multistage speed terminal 3 6: Fault reset 7: Enable control	1	4	★
F4-05	DI5 terminal function selection	8: Maintenance input 9: Emergency input	1	5	★
F4-06	DI6 terminal function selection	10: Running the contactor feedback 11: Holding the lock for feedback 12: Weigh-in terminal 1	1	6	★
F4-07	DI7 terminal functional selection	13: Weigh-in terminal 2 14: Weigh-in terminal 3	1	7	★
F4-08	DI8 terminal function selection	15: Weigh terminal 4 16: External fault 17: The motor is superheated	1	0	★
F4-09	DI9 terminal function selection	18: Upside speed judgment 19: Downlink speed judgment	1	0	★
F4-10	DI10 terminal function selection	The terminal input range is 0-119; where 100 bits indicates that the signal is a normally closed valid type; lower 2 bits is the terminal input function selection, greater than 19 is invalid.	1	0	★
F4-11	continue to have	For example: 106 means that the terminal function is a fault reset function and the signal type is normally closed.	1	0	★
F4-12	continue to have	0.000s—0.200s	0.001	0.005	★
F4-13	Multi-speed combined filtering time	0.000s—0.200s	0.001	0.020s	☆
F5 —— output terminal					
F5-00	The FMR output selection	0: No output 1; In operation 2: Zero-speed operation (zero-speed,	1	15	★

FC	name	description	Minimum unit	Factory value	Change
F5-01	DO1 output selection	effective under operating conditions) 3: Zero speed signal (shutdown also output) 4: Fault signal	1	3	☆
F5-02	DO2 output selection	5: Run the contactor output control 6; Holding lock output control 7: Early door opening signal	1	0	☆
F5-03	The RELAY1 output selection is made	8: The bus is under pressure 9:FDT1 output	1	4	☆
F5-04	The RELAY2 output selection is made	10:FDT2 output 11: Frequency of arrival 12: Overspeed output	1	0	☆
F5-05	continue to have	13: Overload forecast police 14: Running time arrival 15: Ready to run 16: Contact adhesion output control	1	0	☆
F5-06	Zero-speed output lag time	0.000s—3.000s	1	0.000s	☆
F5-07	A0 Output Selection	0: Run frequency 1: Set the frequency 2: Output current 3: Output torque 4; Output voltage 5: AI1 6: AI2	1	0	☆
F5-08	A0 zero partial	-100.0% ~ 100.0%	0.1%	0.0%	☆
F5-09	A0 gain	-10.00~10.00	0.01	1.00	☆
F6 —— speed parameters					
F6-00	Multi-segment speed 0	Maximum frequency of 0 virus	0.01Hz	0.00Hz	★
F6-01	Multi-segment speed 1	Maximum frequency of 0 virus	0.01Hz	0.00Hz	★
F6-02	Multi-segment speed 2	Maximum frequency of 0 virus	0.01Hz	0.00Hz	★

FC	name	description	Minimum unit	Factory value	Change
F6-03	Multi-segment speed 3	Maximum frequency of 0 virus	0.01Hz	0.00Hz	★
F6-04	Multi-segment speed 4	Maximum frequency of 0 virus	0.01Hz	0.00Hz	★
F6-05	Multi-segment speed 5	Maximum frequency of 0 virus	0.01Hz	0.00Hz	★
F6-06	Multi-segment speed 6	Maximum frequency of 0 virus	0.01Hz	0.00Hz	★
F6-07	Multi-segment speed 7	Maximum frequency of 0 virus	0.01Hz	0.00Hz	★
F6-08	Multi-segment speed of 0 acceleration and deceleration time selection	1~4	1	1	★
F6-09	Multi-segment speed-1 acceleration and deceleration time selection	1~4	1	1	★
F6-10	Multi-segment speed-2 acceleration and deceleration time selection	1~4	1	1	★
F6-11	Multi-segment speed-3 acceleration and deceleration time selection	1~4	1	1	★
F6-12	Multi-segment speed-4 acceleration and deceleration time selection	1~4	1	1	★
F6-13	Multi-segment speed-5 acceleration and deceleration time selection	1~4	1	1	★
F6-14	Multi-segment speed-6 acceleration and deceleration time selection	1~4	1	1	★
F6-15	Multi-segment speed of 7 acceleration and deceleration time selection	1~4	1	1	★
F6-16	Maintenance speed selection	0~7	1	0	★
F6-17	Power outage emergency rescue option	0: Motor is not running	1	0	★

FC	name	description	Minimum unit	Factory value	Change
		1: UPS power supply and operation The 2:48V battery provides a power supply			
F6-18	Simog minimum input	0.00V-10.00V	0.01V	0.00V	☆
F6-19	The minimum analog input corresponds to the setting	0.0% ~100.0%	0.1%	0.0%	☆
F6-20	Max. analog input	0.00V ~10.00V	0.01V	10.00V	☆
F6-21	The maximum analog input corresponds to the setting	0.0% ~100.0%	0.1%	100.0%	☆
F6-22	Simog input filter time	0.00s ~10.00s	0.01s	0.10s	☆
F6-23	frequency converter function selection	0 ~65535 BIT0: Set to 1: During normal parking, reduce the current to 0 in (F6-26 + 250) ms time; Set to 0: Original parking mode	1	0	☆
F6-24	Voltage setting when motor overoverheated	0.00V-10.00V	0.01V	0.0 V	☆
F6-26	Stop the current withdrawal time	0~9999ms	0ms	100ms	☆
F6-27	Zero-speed signal output delay	0~9999ms	1	0	☆
F7 ——— curve parameters					
F7-00	Acceleration time 1	1.0s~100.0s	0.1s	4.0s	☆
F7-01	Slow down time 1	1.0s—100.0s	0.1s	4.0s	☆
F7-02	S curve 1 start period	10.0% ~40.0%	0.1%	40.0%	★
F7-03	S curve 1 end period	10.0% ~40.0%	0.1%	40.0%	★
F7-04	Acceleration time 2	1.0S ~100.0S	0.1s	4.0s	☆
F7-05	Slow down time 2	1.0s ~100.0s	0.1s	4.0s	☆
F7-06	S curve 2 start period	10.0% ~40.0%	0.1%	40.0%	★

FC	name	description	Minimum unit	Factory value	Change
F7-07	S Curve 2 End Period Time	10.0% ~40.0%	0.1%	40.0%	★
F7-08	Acceleration time 3	1.0S ~100.0S	0.1s	4.0s	☆
F7-09	Slow down time 3	1.0s ~100.0s	0.1s	20.0s	☆
F7-10	S curve 3 start period	10.0% ~50.0%	0.1%	40.0%	★
F7-11	S Curve 3 End Period	10.0% ~50.0%	0.1%	40.0%	★
F7-12	Acceleration time 4	0.5S ~100.0S	0.1s	1.0s	☆
F7-13	Slow down time 4	0.5s ~100.0s	0.1s	1.0s	☆
F7-14	S curve 4 starts a period	10.0% ~50.0%	0.1%	40.0%	★
F7-15	S curve 4 end period	10.0% ~50.0%	0.1%	40.0%	★
F8 — Keyboard with Display					
F8-00	Input / output terminal status indication	-	-	-	•
F8-01	The LED run will display the parameters	Bit0: Load speed Bit1: Running frequency Bit2: Target Frequency Bit3: DC bus voltage Bit4: Output voltage Bit5: Output current Bit6: AI1 Bit7: AI2 Bit8: Car load of (%) Bit9: Start the compensation current (%) Bit10: Operating torque current: (%) Bit11: Enter the status Bit12: Output state	1	32767	☆
F8-02	LED shutdown display parameters	1-255 0: Target load speed Bit1: Target Frequency	1	255	☆

FC	name	description	Minimum unit	Factory value	Change
		Bit2: DC bus voltage Bit3: AI1 Bit4: AI2 Bit5: Car load: (%) Bit6: Enter the status Bit7: Output state			
F8-03	Load speed display coefficient	0.01-100.00	0.01	0.32	☆
F8-04	Radiator temperature	0.0° C~100° C	w	-	•
F8-05	Software version number 1	0 ~99.99	1		•
F8-06	Software version number 2	0 ~99.99	1	-	•
F8-07	Set the run time	0h~65535h	1h	0h	☆
F8-08	Cumulative working hours	0: Represents that the feature is invalid	1h	0h	•
F8-09	Cumulative second time	0h~65535h	1	0	•
F8-10	High number of runs	0s~3600s	1	0	•
F8-11	Low number of runs	0~9999	1	0	•
F8-12	Power-on short-circuit-to-ground protection detection	0: invalid 1: valid	1	0	☆
F9 —— Fault and Protection					
F9-00	Motor overload protection selection	0: Prohibit 1: Allow	1	1	☆
F9-01	Motor overload protection gain	0.20 ~10.00	0.01	1.00	☆
F9-02	Motor overload early warning factor	50%~100%	1%	80%	☆
F9-03	Overpressure stall gain	0 (No overvoltage stall) 100	1	0	☆
F9-04	Over-voltage stall protection	120% ~150%	1%	130%	☆

FC	name	description	Minimum unit	Factory value	Change
	voltage				
F9-05	Overloss speed gain	0-100	1	20	☆
F9-06	Overcurrent stall protection current	100% ~ 200%	1%	150%	☆
F9-07	Instantaneous stop function	0: Prohibit 1: Allow	1	0	☆
F9-08	Non-stop frequency drop rate	Maximum frequency / s of 0.00Hz / s	0.01 Hz/s	10.00Hz/s	☆
F9-09	Number of automatic reset times of failures	0~3	1	1	☆
F9-10	Selection of the fault relay action during the automatic fault reset	0: Do not move 1: Action	1	0	☆
F9-11	Automatic fault reset interval time	0.1s ~ 100.0s	0.1s	1.0s	☆
F9-12	Enter the missing phase protection selection	0: Prohibit 1: Allow	1	1	☆
F9-13	Output the missing phase protection selection	0: Prohibit 1: Allow	1	1	☆
F9-14	First-time failure type	0: No fault 1: Inverter unit protection (ERR01) 2: Accelerated overcurrent (ERR02) 3: Slow overcurrent (ERR03) 4: Constant speed overcurrent (ERR04) 5: Accelerated overvoltage (ERR05) 6: Slow overvoltage (ERR06) 7: Constant speed overvoltage (ERR07) 8: Control power supply failure (ERR08) 9: Undervoltage fault (ERR09)	-	-	•

FC	name	description	Minimum unit	Factory value	Change
		10: Frequter overload (ERR10) 11: Motor overload (ERR11) 12: Input the missing phase (ERR12) 13: Output phase absence (ERR13) 14: Radiator overheating (ERR14) 15: External fault (ERR15) 16: Communication fault (ERR16) 17: Keep 18: Current detection fault (ERR18) 19: Motor tuning fault (ERR19) 20: Code disk failure (ERR20) 21; Rotary encoder fault (ERR21) 22: Contact adhesion (ERR22) 23: Motor short circuit to ground fault (ERR23) 25: Data storage fault (ERR25) 32: Battery Operation Overspeed (ERR32) 33: Overspeed fault (ERR33) 34: Speed deviation is too large (ERR34) 36: contactor fault (ERR36) 37: Lock holding fault (ERR37) 38; Contact adhesion (ERR38) 39: Motor overheat (ERR39) 40: Elevator operating conditions are not met (ERR40)			
F9-15	Second failure type		-	-	•
F9-16	Last time failure type		-	-	•
F9-17	Frequency of failure	-	-	-	•
F9-18	Current in case of failure	-	-	-	•
F9-19	Bus voltage in fault	-	-	-	•

FC	name	description	Minimum unit	Factory value	Change
F9-20	Input terminal at fault	-	-	-	•
F9-21	Output terminal in case of failure	-	-	-	•
FA—PG parameter					
FA-00	PG pulse count	100-10000	1	1024	★
FA-01	PG disconnection detection time	0s ~ 10.0s (less than 2S, invalid detection function)	0.1s	3.0s	★
FA-02	continue to have	-	-	-	-
FA-03	PG Magnetic Pole Angle	0.0 ~ 359.9	0.1	0.0	★
FA-04	PG magnetic pole current angle	0.0 ~ 359.9	0.1	0.0	•
FA-05	UVW type wiring mode	0 ~ 3	1	0	★
F B — communication parameters					
FB-00	Baud rate	0: 300BPS 1: 600BPS 2: 1200BPS 3: 2400BPS 4: 4800BPS 5: 9600BPS 6: 19200BPS 7: 38400BPS	1	5	☆
FB-01	data format	0: No check 1: Double check 2: Strange verification	1	0	☆
FB-02	This machine address	1126,127 is the broadcast address	1	1	☆
FB-03	Response delay	0ms ~ 20ms	1	2	☆
FB-04	Communication timeout time	0.0 (invalid), 0.1S 100.0s	0.1s	0.0	☆
FC — -specific enhancements					
FC-00	Command Exception action selection	0: Slow down 1: Block off the output immediately	1	1	★
FC-01	Abnormal deceleration time selection	0.1s ~ 300.0s	0.1s	3.0s	★

FC	name	description	Minimum unit	Factory value	Change
FC-02	Upward frequency detection level	0.00 Maximum frequency	0.01Hz	45.00Hz	★
FC-03	Downlink frequency detection level	0.00 Maximum frequency	0.01Hz	45.00Hz	★
FC-04	Open the door in advance to judge	0.00 Maximum frequency	0.01Hz	5.00Hz	★
FC-05	Frequency detection level 1	0.00 Maximum frequency	0.01Hz	50.00Hz	☆
FC-06	Frequency detection level 2	0.00 Maximum frequency	0.01Hz	50.00Hz	☆
FC-07	Frequency detection lag	0.0% 100.0% (Frequency detected level)	0.1%	5.0%	☆
FC-08	Frequency reaches the detected width	0.0% 100.0% (Maximum frequency)	0.1%	0.0%	☆
FC-09	Overspeed judgment level	80% ~ 120%	1%	115%	☆
FC-10	Overspeed detection delay time	0.0s ~ 5.0s	0.1s	1s	☆
FC-11	Overspeed action selection	0: Abnormal deceleration and stop 1: Alarm the police and block the output immediately 2: Continue running	1	1	☆
FC-12	Speed deviation judgment level	0% ~ 50%	1%	30%	☆
FC-13	Speed deviation detection delay time	0.0s ~ 5.0s	1s	1s	☆
FC-14	Speed deviation is excessive action selection	0: Abnormal deceleration and stop 1: Alarm the police and block the output immediately 2: Continue running	1	2	☆
FC-15	Holding lock and operation timing selection	0: First output operation, then output lock control 1: Output the lock control first, and then output the operation	1	0	☆

FC	name	description	Minimum unit	Factory value	Change
FD—— specific function					
FD-00	Recurrent ascension	0.0: (Automatic) 0.1 % ~ 30.0%	0.1%	1.0%	★
FD-01	Recurrent lifting frequency	Maximum frequency of 0 virus	0.01Hz	50.00Hz	★
FD-02	Transfer difference compensation	0.0% ~ 200.0%	0.1%	100.0%	★
FD-03	Oscillation inhibits gain	0—100	1	20	★
FD-05	Zero servo current coefficient	1.0% ~ 50.0%	0.1%	15.0%	☆
FD-06	Zero-servo speed loop KP	0.05 ~ 1.00	0.01	0.50	☆
FD-07	Zero-servo speed loop TI	0.05-2.00	0.01	0.60	☆
FP one-by-one user password					
FP-00	User password	0-65535 0: indicates no password	1	0	☆
FP-01	Parameter update	0: No 1: Restore the factory parameters 2: Clear the memory information	1	0	★
FP-02	The user sets the urine test	0: invalid 1: valid	1	0	★

Chapter VI: Application and Commissioning

This chapter mainly introduces the use of several 820 series elevator special inverter methods, as well as the typical working conditions, such as power failure emergency operation, maintenance operation, etc.

6.1 Multisegment speed control mode

Multi-segment speed control mode is a more common way of elevator control application, which is characterized by strong anti-interference ability, good adaptability, and the scheme is easy to achieve. However, in the traditional multi-segment speed control, the acceleration and deceleration curves of different speed combination switching are the same and affect each other, so that users can ignore one and lose the other in the actual debugging process. The 820 series frequency converter is specially designed for the characteristics of multi-segment speed control: each multi-segment speed combination can flexibly correspond to different acceleration and deceleration curves. It facilitates user debugging in practical applications.

6.1.1 Wiring diagram of multiple-segment speed control system

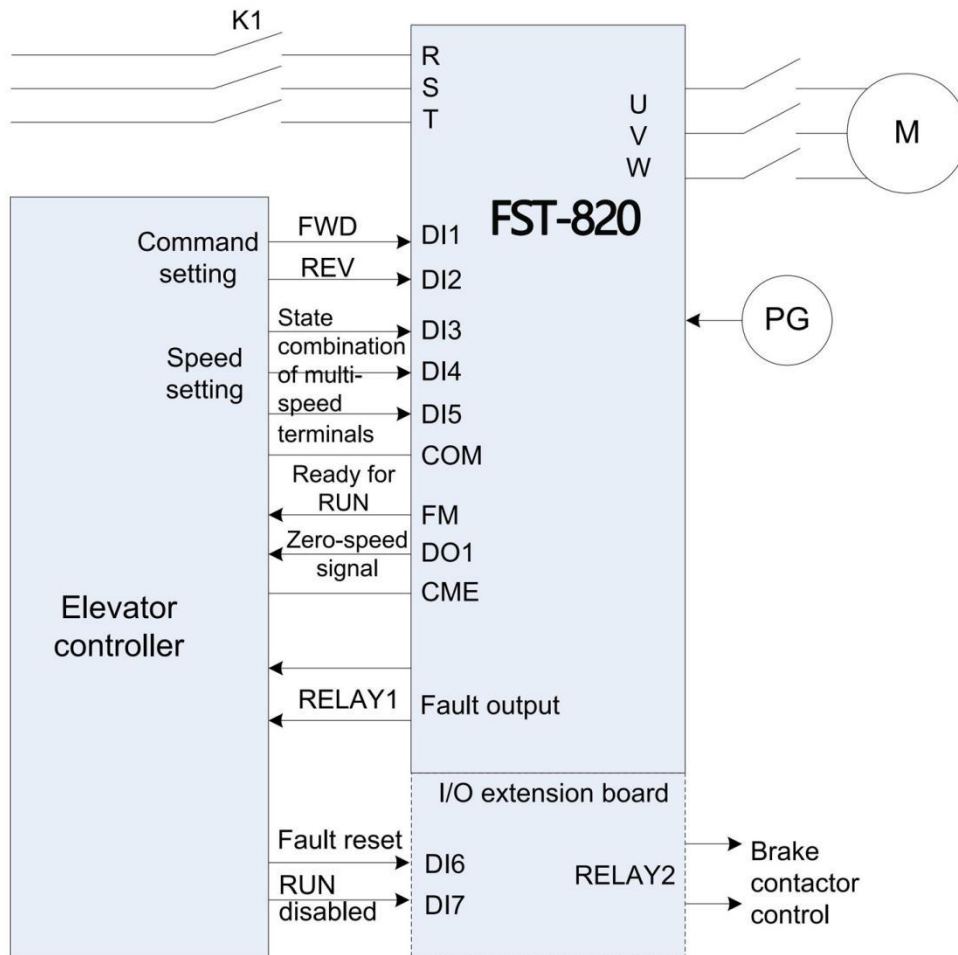

Figure 6-1 Multi-segment speed control wiring diagram

6.1.2 Score setting

According to the order of elevator debugging, for the most typical usage, that is, corresponding to the figure 6-1 above (no expansion card) part, the parameters are adjusted in three times: motor tuning, maintenance operation, express

operation. More input and output, such as enabling functions, can be achieved by adding an extension card.

1. Commissioning of frequency converter for asynchronous motor

1) Aynchronous motor tuning process

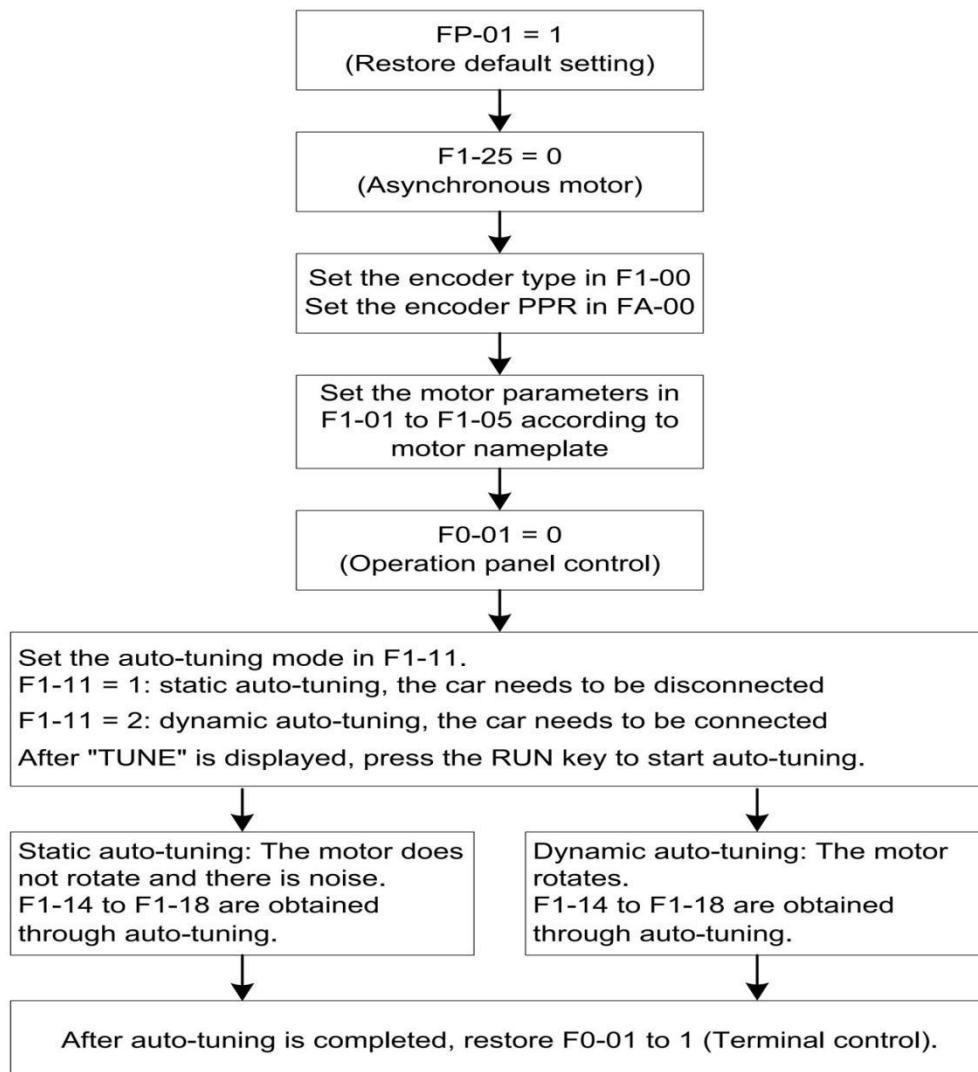

Figure 6-2

2) Maintenance and operation

Elevator commissioning enters the maintenance operation stage. Before the maintenance operation, the frequency converter shall be set:

A. If the closed-loop runs, the FA-00 is set as the corresponding number of pulses. Set F0-00 = 0 if used for open loop operation.

B. Frequency corresponding to the maintenance speed segment combination (set one parameter in F6-00~F6-07 according to the speed segment combination adopted in the system, assumed to be F6-0N);

C. Curve corresponding to the maintenance and maintenance operation (set F6-M, M=N + 8, and the set range is 14);

D. Increase and deceleration time of maintenance operation (set the corresponding increase and deceleration time according to the selected curve. The set value size is determined by the ladder speed).

Note: If the inverter wiring adopted by the system is to increase the expansion card, or the terminal function used is not consistent with the schematic diagram, please set the corresponding parameters of the F4 and F5 groups before the

maintenance and operation.

3) The Express train is running

The elevator enters the express debugging stage, and the frequency converter needs to be adjusted with the comfort of the elevator. The parameters are set as follows:

A. Please confirm that the frequency converter, the encoder is connected, and confirm that the FA-00 PG pulse number is set correctly, and ensure that the F0-00=1 has the speed sensor vector control.

B. Set all the frequency values corresponding to the speed segment combination.

C. Set the curve corresponding to each frequency value.(Recommended curve 1 is used for express operation, and for the lowest speed in the express train if the express is divided into several speeds.)

D. Set the acceleration and deceleration time of each curve according to the comfort, and the start and end time of the curve.

E. Adjust the parameters of groups F2 and F3 according to the operating comfort and start-stop comfort.

4) Application examples

The following list is the 1 m/s of FIG. 6-1, the speed section combination adopts multisegment speed 2 for maintenance, 3 as crawling, 7 as a high-speed elevator without weighing device, the final set parameters (only list the different parameters from the factory parameters, and not including the motor parameters):

FC	name	set value	FC	name	set value	FC	name	Set value
F6-02	Multi-segment speed 2	10	F6-10	Multi-segment speed-2 acceleration and deceleration time selection	4	F7-12	Acceleration time 4	1.8
						F7-13	Slow down time 4	0.6
F6-03	Multi-segment speed 3	3	F6-11	Multi-segment speed-3 acceleration and deceleration time selection	3	F7-08	Acceleration time 3	0
						F7-09	Slow down time 3	20
F6-07	Multi-segment speed 7	48	F6-15	Multi-segment speed of 7 acceleration and deceleration time selection	1	F7-00	Acceleration time 1	3.6
						F7-01	Slow down time 1	4.2
						F7-02	S curve 1 start period	40
			F6-16	Maintenance speed selection	2	F7-03	S curve 1 end period	40

2. Commissioning of IP models

1) Synchronous motor tuning process

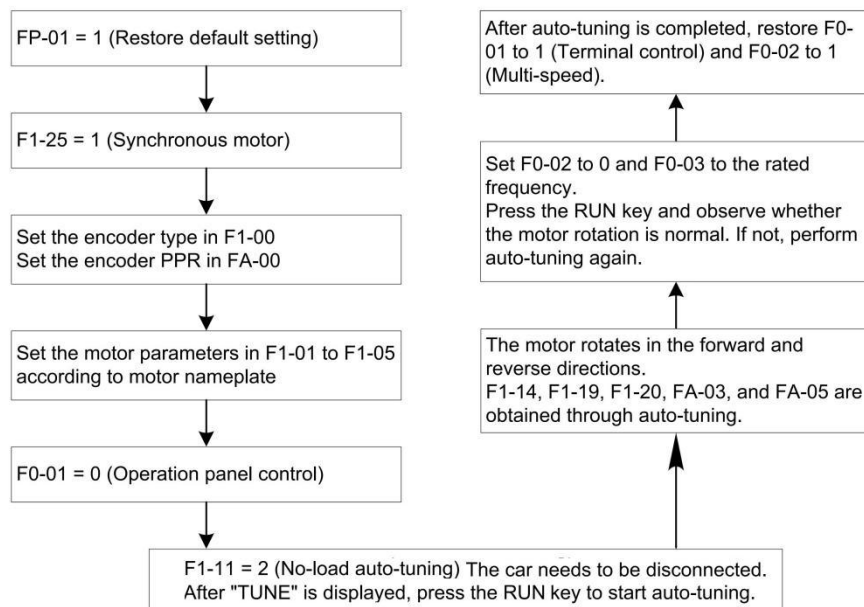
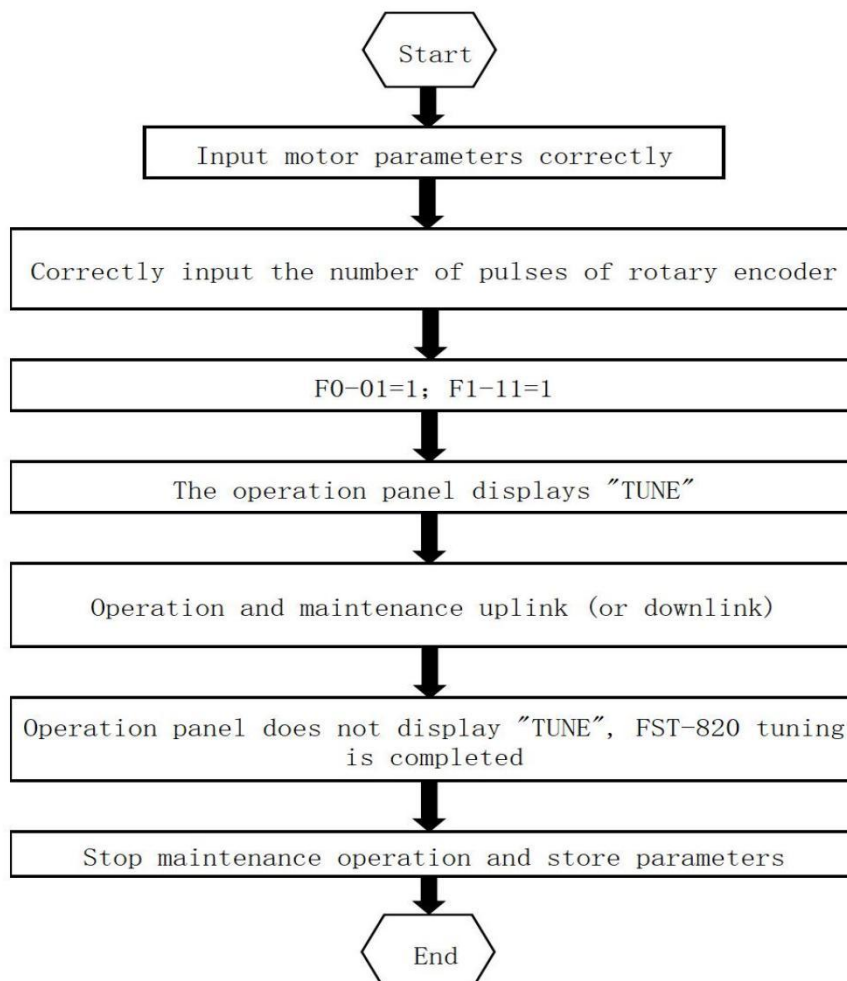

Figure 6-3

2) The load-free encoder angle identification function

A, usage method

In order to facilitate the use of synchronous motor application field, 820 elevator special inverter is designed. Using this method, the user no longer needs to remove the wire rope of the elevator to complete the encoder angle identification. The operation steps are as follows:



B, matters need attention

A) Due to the end of the tuning process, 820 will not output the current when the storage parameters are used, therefore, under the use of this function, the elevator control system should string the lock function of 820 into the lock loop of the system to avoid the elevator "sliding" in this process.

After b) tuning, 820 will have a 5-second storage time, when 820 does not respond to the input command.

The load-free Angle identification function of c) 820 requires professional personnel operation to avoid danger.

d) At the start of tuning, cancel the function software without weighing pre-torque compensation to avoid abnormalities;

e) If the tuning cannot be completed normally, please switch any two units in the output power line UVW of the frequency converter;

3) Maintenance and operation

Elevator commissioning enters the maintenance operation stage. Before the maintenance operation, the frequency converter shall be set:

A. Before operation, please confirm the encoder wiring and the output of the inverter to the U, V and W phases on the motor side. The order is not changed after the motor is learned.

B. Frequency corresponding to the maintenance speed segment combination (set one parameter in F6-00, F6-07, according to the speed segment combination adopted in the system, assuming F6-0N);

C. Curve corresponding to the maintenance and maintenance operation (set F6-M, $M=N + 8$, and the set range is 14);

D. Increase and deceleration time of maintenance operation (set the corresponding increase and deceleration time according to the selected curve, and the set value size is determined by the ladder speed).

Note: If the inverter wiring adopted by the system is to increase the expansion card, or the terminal function used is not consistent with the schematic diagram, please set the corresponding parameters of the F4 and F5 groups before the maintenance and operation.

4) The Express train is running

The elevator enters the express debugging stage, and the frequency converter needs to be adjusted with the comfort of the elevator. The parameters are set as follows:

A. Before operation, please confirm the encoder wiring and the output of the inverter to the U, V and W phases on the motor side. The order is not changed after the motor is learned.

B. Set all the frequency values corresponding to the speed segment combination.

C. Set the curve corresponding to each frequency value. (Recommended curve 1 is used for express operation, and for the lowest speed in the express train if the express is divided into several speeds.)

D. Set the acceleration and deceleration time of each curve according to the comfort, and the start and end time of the curve.

E. Adjust the parameters of groups F2 and F3 according to the operating comfort and start-stop comfort.

5) Application examples

The following list is the 1 m/s of FIG. 6-1, the speed section combination adopts multi-section speed 2 for maintenance, 3 as crawling, 7 as a high-speed elevator without weighing device, the final set parameters (only the different parameters from the factory parameters, and the motor and code plate parameters are not included):

FC	name	set value	FC	name	set value	FC	name	set value
F6-02	Multi-segment speed 2	10	F6-10	Multi-segment speed-2 acceleration and deceleration time selection	4	F7-12	Acceleration time 4	The synchronous machine acceleration and deceleration time setting is related to the elevator rated speed and the motor rated frequency
						F7-13	Slow down time 4	
F6-03	Multi-segment speed 3	3	F6-11	Multi-segment speed-3 acceleration and deceleration time selection	3	F7-08	Acceleration time 3	
						F7-09	Slow down time 3	
F6-07	Multi-segment speed 7	48	F6-15	Multi-segment speed of 7 acceleration and deceleration time selection	1	F7-00	Acceleration time 1	
						F7-01	Slow down time 1	
						F7-02	S curve 1 start period	
						F7-03	S curve 1 end period	
F6-16	Maintenance speed selection				2			

Note: See Section 6.4 for the emergency leveling function of the synchronous machine.

6.2 Simulation quantity control mode

820 series frequency converter in the application of elevator also has a common way: to simulate the quantity speed given way. In this control mode, the speed of the frequency converter is given with analog quantity input, and the operation command is given with terminal input. The control use is briefly introduced below.

6.2.1 Wiring diagram of the analog placement control system

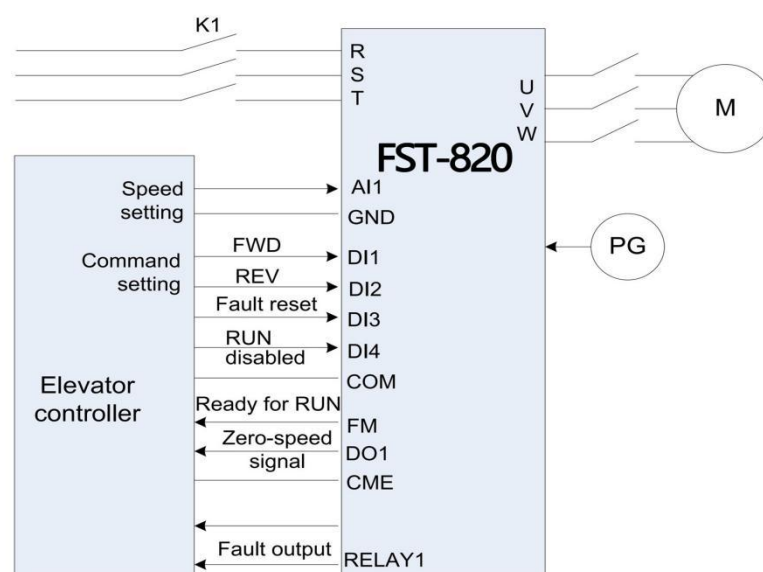

Figure 6-5

6.2.2 Parameter setting

In the analog volume control system, the frequency converter, as an executor, fully follows the command of the controller, such as that used in the figure above, and the analog volume input signal is assumed to be 0 + 10V input. The required adjustment parameters are as follows:

	FC	name	set value	FC	name	Set value
Simog function parameters	FO-02	Speed selection	2	F6-18	Simog minimum input	0
	F6-19	The minimum analog input	0	F6-20	Max. analog input	10
	F6-21	The maximum analog input	100	F8-22	Simog input filter time	0.1
Motor disk	F1 ,FA	For self-learning by the motor, see multiple speed control synchronization and				
Vector control of the velocity loop	F2	Adjust according to the actual operation characteristics				
The input and output terminals	F4-03	DI3 terminal functional selection	7	F4-04	DI4 terminal function selection	6

6.3 Repair and operation

The 820 series frequency converter is in the multi-segment speed control mode, with a built-in maintenance operation mode, which is handled accordingly according to the characteristics of the elevator maintenance operation. The following briefly describes the control process and the running curve.

6.3.1 System wiring diagram

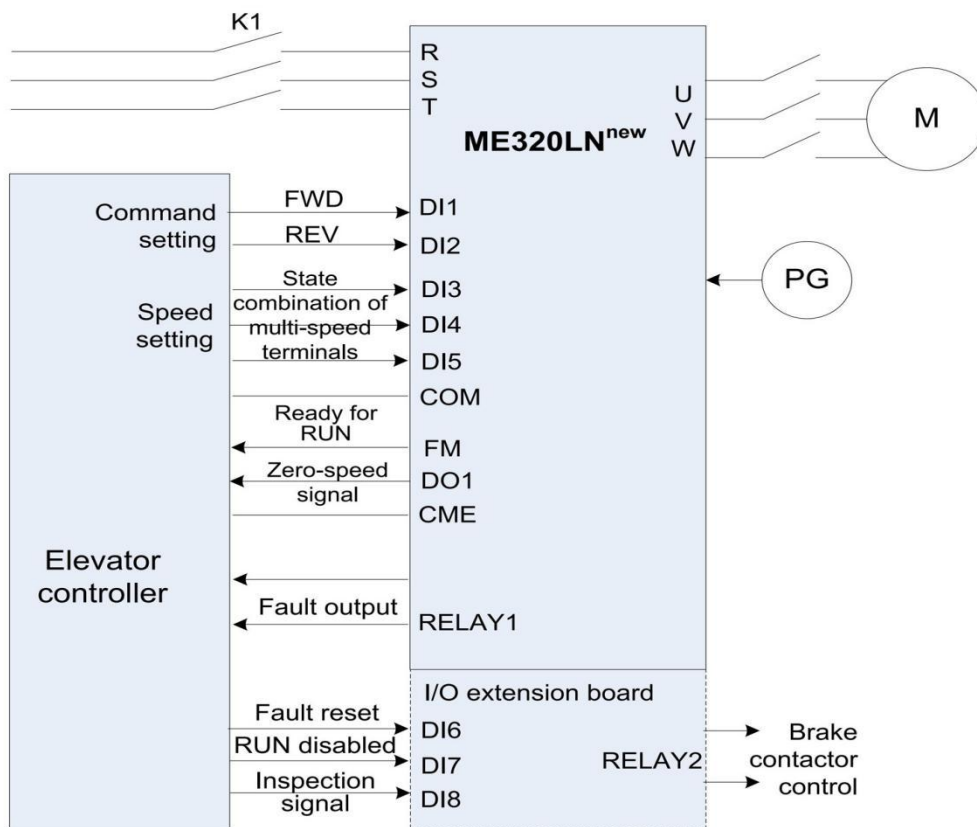

Figure 6-6

6.3.2 Parameter setting and operation diagram

Maintenance operation, as a special working condition, has strict national standard requirements, and its operation curve is also very different from the operation of the elevator express.

The 820 series frequency converter is in the multiple-segment speed control mode, if the maintenance input is valid, the maintenance operation speed will be judged according to the function code setting of F6-16. For example, F6-16=3, if the elevator has a positive turn (reverse) command and an maintenance input terminal signal, 820 will operate at the target frequency of the multiple speed 3, and the acceleration time is determined according to the corresponding time curve of the multiple speed 3. During the shutdown process, if the maintenance input signal is removed first, the system will slow down to 0 according to the deceleration time of multiple speed 3, until the positive or reverse command is withdrawn (as shown below, the deceleration process can be set for a very short deceleration time, such as 1s, so that a fast shutdown can be guaranteed).

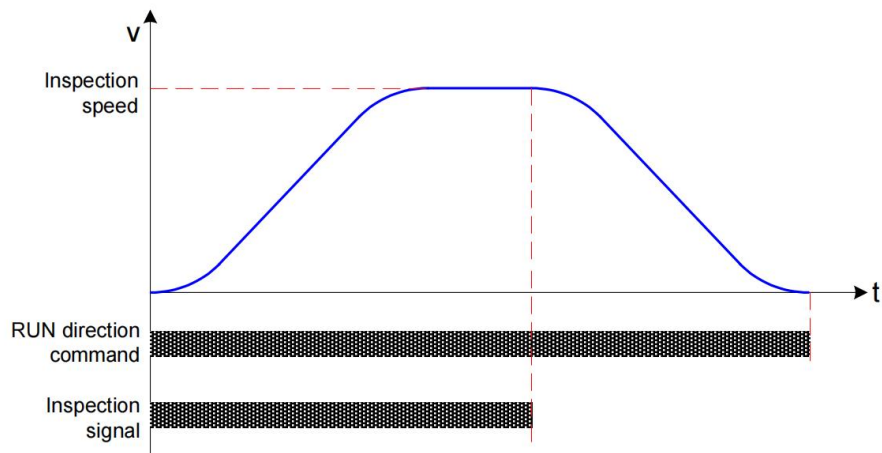

Figure 6-7

If the command is directly reversed or reversed, 820 stops the output immediately. As shown in the figure below

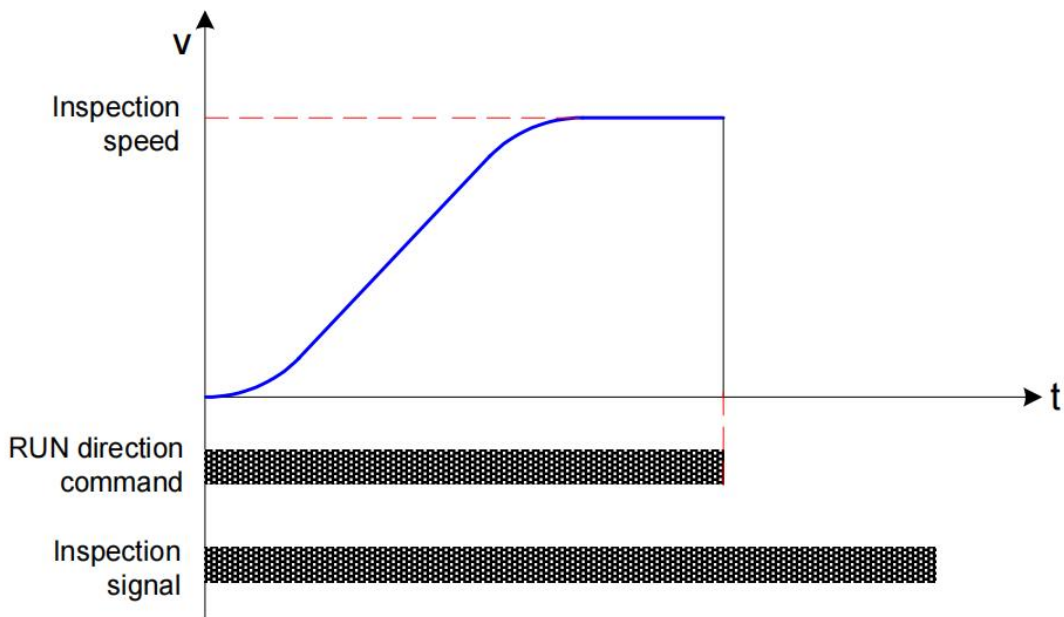

Figure 6-8

For a 1 m/s elevator, using multiple speed 5 and multiple speed 5, the set maintenance speed parameters are as follows:

FC	name	set value	Factory value	remarks
F6-05	Multi-segment speed 5	10.00Hz	0.00Hz	Rated motor speed is 50.00Hz
F6-13	Multi-segment speed-5	4	1	
F6-16	Maintenance speed	2	0	The maintenance speed section is selected as multiple
F7-12	Acceleration time 4	2.0s	20.0s	
F7-13	Slow down time 4	1.0s	20.0s	The parameter value shall be set sufficiently small to reduce the speed to a minimum before closing.

6.4 Power outage emergency operation

During the use of the elevator, if the system suddenly loses power, it may cause passengers to be shut down in the car.820 Use two blackout emergency operation modes: UPS power supply operation and 48V battery operation.

Power supply operation of 48V battery: the main loop of 820 is powered by 48V battery, and the other working power supply of the elevator is powered by UPS (or inverter power supply) greater than 220V. In this way, the motor uses the battery power for operation, and the capacity of the working power supply can be very small.

UPS power supply operation: both the main circuit and working power supply of 820 are powered by UPS for emergency power failure operation.

The 48V battery power supply operation mode is described as an example below.

6.4.1 Wiring diagram of blackout emergency operation system (48V battery power supply)

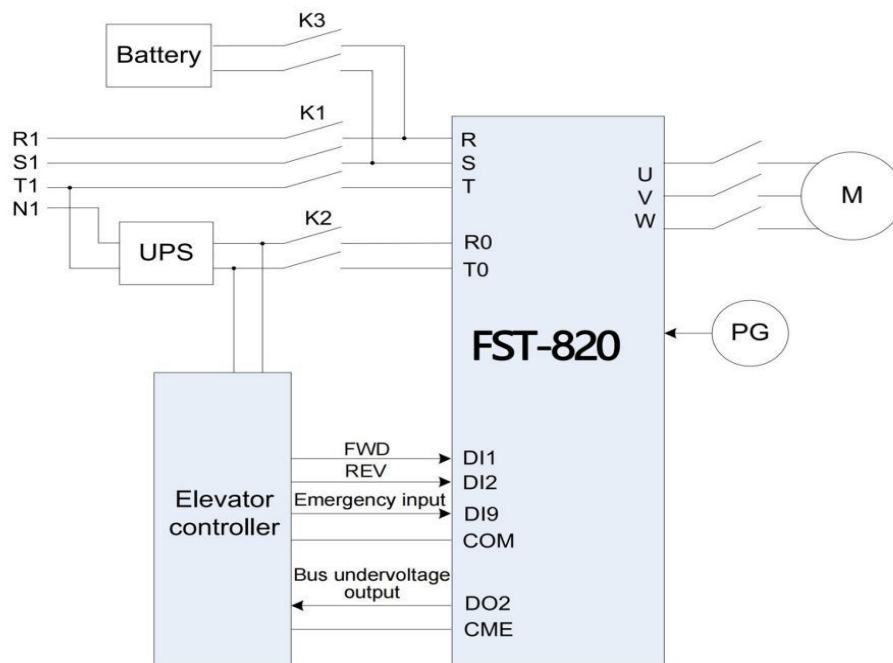

Figure 6-9

6.4.2 Operation time sequence

820 In the multi-segment speed combination mode, the wiring is conducted according to the above figure, where D01 serves as the port of the normal output of the bus bar. Adopt the multiple-segment speed combination 2 as the emergency operation speed combination. Therefore, in the multi-segment speed control mode, set the following function code:

FC	name	set value	Factory value	remarks
F5-01	D01 Output Selection	8	3	The bus is under pressure
F6-02	Multi-segment speed 2	2.00Hz	0.00Hz	Rated motor speed is 50.00Hz
F6-10	Multi-segment speed-2	3	1	
F7-08	Acceleration time 3	30.0s	20.0s	Increase the acceleration time to avoid excessive

The above row direction is an example, and the operation sequence is as follows:

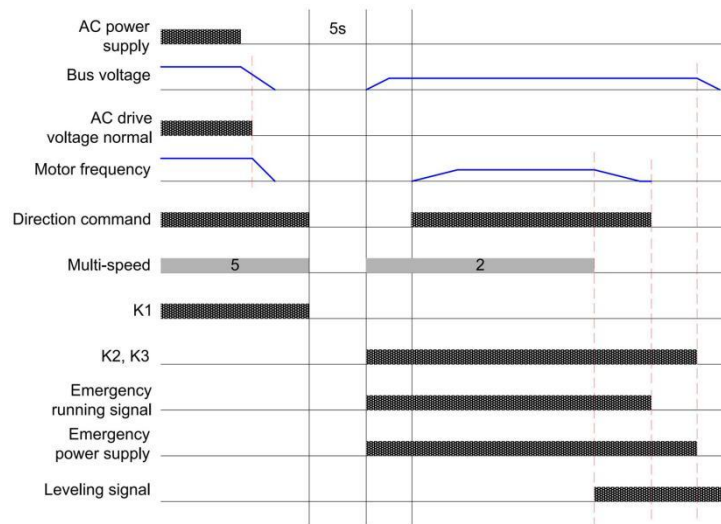

Figure 6-10

The battery operation signal is the signal provided by the elevator controller, which is connected to the 820 through the DI terminal to determine whether the current operation is the battery operation. Contactors K1, K2, and K3 are controlled by the elevator controller.

6.4.3 Notes

1) According to the actual situation of the elevator, set the operation speed and the deceleration time of the battery. The acceleration and deceleration time is recommended to be more than 10s. The battery operating speed is set according to the following formula:

$$\text{Battery operating speed} < (48V - 5V) * \text{Motor rated frequency} / (1.414 * \text{Rated voltage})$$

2) Input the DC voltage of 48V to the main circuit through the storage battery; and input the working power supply through the auxiliary power supply such as UPS;

3) The stable output current of the battery is recommended to be greater than the no-load current of the traction machine;

4) 820 According to determine whether the operation is the input terminal (DI), the operation speed of 820 is given by multiple speeds, and the corresponding time is the acceleration and deceleration time of the battery; unlike normal operation, the curve acceleration and deceleration is linear acceleration and deceleration;

5) During the operation of the battery, the 820 frequency converter does not conduct DC bus voltage detection, so during the lock opening process, the main circuit of the 820 frequency converter has input 48V voltage;

6) During the battery operation, the 820 will be speed monitored and, if the speed exceeds 8Hz, it will be faulty, and protection (E032);

7) The battery should be avoided when driving the load operation, so the external controller should choose the operation direction of balancing load or brake load;

8) During the operation of power outage emergency operation, it is necessary to pay attention to the working sequence of the contactor connecting the main power supply of the inverter and the UPS, which should not be closed at the same time to avoid damage to UPS and battery.

6.5 Simulation volume weighing and debugging

In 820, the elevator should be run up according to FWD (forward) and REV (reverse) is the elevator down. The following simulation weighing and debugging method is discussed based on this.

6.5.1 Parameter setting method

Assuming that AI1 is used as the pre-torque input channel, then the parameter F3-09=2; F3-10= the elevator balance coefficient. In the case of empty load, the AI1 takes the sample value to F3-18, and the sample value of AI1 is input to F3-19 when the car is fully loaded. The above two parameters can also be determined by weighing for self-learning.

Finally, adjusting F3-11 to select the appropriate compensation can generally be set to around 0.6.

6.5.2 Commissioning method with inaccurate balance coefficient

In some meetings, after the empty load compensation is correct, the effect of the load increase effect in the car will become worse, because the balance coefficient of the elevator is not accurate.

In the case that the balance coefficient is unknown, the balance coefficient and F3-11 (gain) can be determined by the no-load and full-load two-point compensation method to make the system compensation effect consistent.

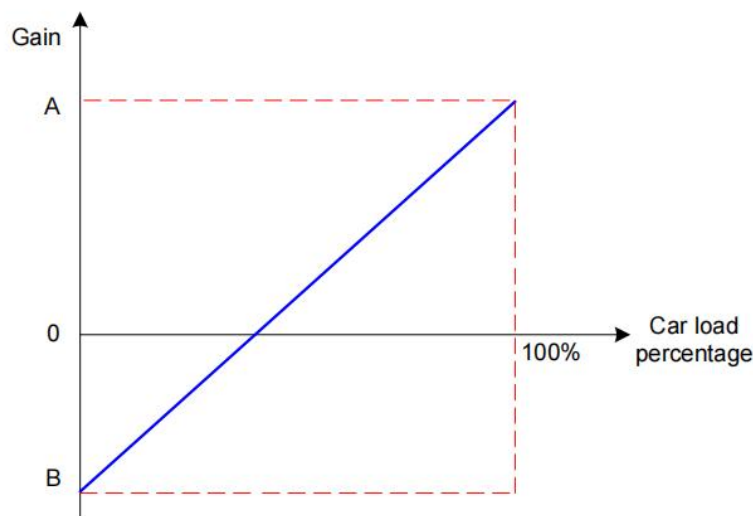

Figure 6-11

As shown above, F3-10 is set to 50%, in the car no-load self-learning, then the elevator up and down, adjust F3-11, observe whether the motor slips in the elevator up and down torque compensation, record F3-11=B; then add full load self-learning, and adjust F3-11, again, if the compensation is right, F3-11=A0

As can be seen from the figure, the inclined line is the correct compensation curve of the elevator, and the point where this curve passes through the horizontal axis is the balance compensation point of the elevator, corresponding to the balance coefficient of the elevator. According to the above test, geometric calculation:

$$F3-10=100*B/(A+B); \quad F3-11=(A+B)/2;$$

For example, get B=0.7 for no-load test and A=0.4 for full load; so the corresponding equilibrium coefficient is set to F3-10=36.4% and F3-11=0.55.

6.5.3 Commissioning method with opposite running direction

If the site has been set to correspond to the downside, the reversal corresponds to the upside, the above method will worsen the compensation. The reason is that the compensation direction is reversed. In this case, first record the no-load and full-load sample values F3-18, F3-19 and the balance coefficient F3-10, such as F3-18=X; F3-19=Y; F3-10=Z; then F3-19=X; F3-18=Y; F3-10=100-Z.

6.6 No weighing and debugging method

6.6.1 Basic parameter setting

parameter declaration	parameter	Set the value
Encoder type selection	F1-00	0
Selection of weighing method	F3-09	5
Lock opening time (zero-speed holding time)	F3-04	More than 0.5 seconds

6.6.2 Basic parameter setting

Gradually increase the zero servo current coefficient (FD-05) value, until the lock is open after the reverse slip is small enough, and the motor does not shake;

Commissioning program can use the version number (F8-06) parameters to observe the slip of zero servo, in which 100 represents the distance of a tooth, generally adjusted to a person when the slip within a tooth can basically be;

If the zero servo speed loop TI (FD-07) is still less than 1.00, the motor appears obvious oscillation, increase the zero servo current coefficient (FD-05) value;

Zero servo speed loop KP (FD-06) can be basically maintained unchanged, do not adjust too much, otherwise it is easy to cause motor oscillation.

Chapter VII: Fault Diagnosis and Countermeasures

7.1 Fault alarm and countermeasures

820 The converter has 40 warning information and protection functions. Once an abnormal fault occurs, the protection function acts, the frequency converter stops output, the frequency converter fault relay contact acts, and the fault code is displayed on the display of the frequency converter panel. Before seeking services, users can follow the prompts in this section to analyze the cause of the fault and find out the solution. If you still have questions, please seek service, contact the dealer of your inverter or contact us directly.

[Note] Err33> Err16> Err17 cannot be reset, and it must be power-off and reset.

7.2 Common faults and their handling methods

Fault code	Fault name	Troubleshooting	Troubleshooting countermeasures
Err01	Inverter unit protection	<ol style="list-style-type: none"> 1. Main short or ground circuit; 2. The traction machine connection is too long; 3. Overheated working environment; 4. The internal connection of the controller is loose; 	<ol style="list-style-type: none"> 1. Eliminate external problems such as wiring; 2. Add up the reactor or the output filter; 3. Check whether the air duct and the fan are normal; 4. Please contact the agent or the manufacturer;
Err02	Accelerate over current	<ol style="list-style-type: none"> 1. Main short or ground circuit; 2. Whether the motor has been tuned with the parameters; 3. Too much load; 	<ol style="list-style-type: none"> 1. Eliminate external problems such as wiring; 2. Motor parameter tuning; 3. Reduce the sudden adding load;
Err03	Slow down over current	<ol style="list-style-type: none"> 1. Main short or ground circuit; 2. Whether the motor has been tuned with the parameters; 3. Too much load; 4. The deceleration curve is too steep; 	<ol style="list-style-type: none"> 1. Eliminate external problems such as wiring; 2. Motor parameter tuning; 3. Reduce the sudden adding load; 4. Adjust the curve parameters;
Err04	Constant speed over current	<ol style="list-style-type: none"> 1. Main short or ground circuit; 2. Whether the motor has been tuned with the parameters; 3. Too much load; 4. Large interference of the code disk; 	<ol style="list-style-type: none"> 1. Eliminate external problems such as wiring; 2. Motor parameter tuning; 3. Reduce the sudden adding load; 4. Select the appropriate code plate, and adopt the shielding code plate line;
Err05	Accelerated overvoltage	<ol style="list-style-type: none"> 1. High input voltage; 2. The elevator inverted is serious; 3. The brake resistance selection is too large, or the brake unit is abnormal; 4. The acceleration curve is too steep; 	<ol style="list-style-type: none"> 1. Adjust the input voltage; 2. Adjust the start-up time sequence of the elevator operation; 3. Select the appropriate brake resistance; 4. Adjust the curve parameters;

Fault code	Fault name	Troubleshooting	Troubleshooting countermeasures
Err06	Slow down over voltage	<ol style="list-style-type: none"> 1. High input voltage; 2. The brake resistance selection is too large, or the brake unit is abnormal; 3. The deceleration curve is too steep; 	<ol style="list-style-type: none"> 1. Adjust the input voltage; 2. Select the appropriate brake resistance; 3. Adjust the curve parameters;
Err07	Constant speed overvoltage	<ol style="list-style-type: none"> 1. Input voltage is too high; 2. The brake resistance selection is too large, or the brake unit is abnormal; 	<ol style="list-style-type: none"> 1. Adjust the input voltage; 2. Select the appropriate brake resistance;
Err08	Control power failure	<ol style="list-style-type: none"> 1. Input voltage is too high; 2. Abnormal drive control board; 	<ol style="list-style-type: none"> 1. Adjust the input voltage; 2. Please contact the agent or the manufacturer;
Err09	Underpressure failure	<ol style="list-style-type: none"> 1. Instant power failure of the input power supply; 2. The input voltage is too low; 3. Abnormal drive control board; 	<ol style="list-style-type: none"> 1. Eliminate external power supply problems; 2. Please contact the agent or the manufacturer;
Err10	Frequency converter overload	<ol style="list-style-type: none"> 1. Abnormal lock holding circuit; 2. Too much load; 	<ol style="list-style-type: none"> 1. Check the lock circuit and provide power supply; 2. Reduce the load;
Err11	Motor overload	<ol style="list-style-type: none"> 1. F9-01 Improper setting; 2. Abnormal lock holding circuit; 3. Too much load; 	<ol style="list-style-type: none"> 1. Adjust the parameters; 2. Check the lock circuit and provide power supply;
Err12	Input phase-deficiency protection	<ol style="list-style-type: none"> 1. Input power supply asymmetry; 2. Abnormal drive control board; 	<ol style="list-style-type: none"> 1. Adjust the input power supply; 2. Please contact the agent or the manufacturer;
Err13	Output phase-deficiency protection	<ol style="list-style-type: none"> 1. Loose output wiring of the main circuit; 2. Damaged motor; 	<ol style="list-style-type: none"> 1. Check the connection; 2. Troubleshoot the motor fault;
Err15	External failure	<ol style="list-style-type: none"> 1. The ambient temperature is too high; 2. Damage of the fan; 3. Air duct blockage; 	<ol style="list-style-type: none"> 1. Reduce the ambient temperature; 2. Clean up the air duct; 3. Replace the fan;
Err16	Communication failure	Elevator controller fails	Check whether the elevator controller is working properly

Fault code	Fault name	Troubleshooting	Troubleshooting countermeasures
Err17	Encoder failure	Encoder failure in shutdown state	In the shutdown state, for continuous 50ms, the deviation of the angle calculated through the encoder CD signal and the current real-time angle are too large. If the AB accumulation signal is correct, it can be considered that the CD signal is very greatly disturbed.
Err18	Current detection failure	The encoder failed during operation	During the operation, three consecutive times, when the encoder Z signal arrives, the angle accumulated through AB is too much. If the CD signal in the absolute position is correct, it is possible that Z is disturbed;
Err19	Motor tuning fault	Drive control board is abnormal;	Please contact the agent or the manufacturer;
Err20	Code disk failure	1. Improper setting of motor parameters; 2. Parameter tuning timeout;	1. Correct input of the motor parameters; 2. Check the motor leads;
Err21	Rotation encoder fault		
Err 22	continue to have		
Err 23	Short circuit protection to the ground	Output is short-circuit to the ground;	Check whether the motor or output side contactor is short circuit to the ground; please contact the agent or manufacturer;
Err25	Data storage failure		
Err32	Battery running overspeed	The battery speed exceeds 8Hz during operation	Check whether the battery voltage is normal; check whether the line is loose;
Err33	Overspeed failure	The running speed of the frequency converter exceeds the overspeed judgment level, and the cumulative time is greater than the overspeed judgment time.	1. Check whether the motor power is matched; 2. Check whether the elevator is too heavy; 3. Check whether the rotary encoder signal is correct;

Fault code	Fault name	Troubleshooting	Troubleshooting countermeasures
Err 36	Contact failure	When the lock is opened, the motor current is zero; during the elevator operation, the contactor feedback signal is lost for more than 1s; No feedback signal after the contactor is closed;	<ol style="list-style-type: none"> 1. Check whether the contact contacts and feedback contacts are normal; 2. Check whether the output lines U, V and W of the elevator integrated controller are connected normally; 3. Check whether the power supply of the contactor control circuit is normal;
Err37	Lock failure	The lock output is inconsistent with the feedback signal for more than 2s	<ol style="list-style-type: none"> 1. Check whether the lock switch coil and the feedback contact point are normal; 2. Confirm the signal characteristics of the feedback contact point (often open and often closed); 3. Check whether the power supply of the lock coil control circuit is normal;
Err38	Contact adhesion	Inter of brake and running contactor when stopping The feed signal remained valid for more than 2s	<p>Check wiring;</p> <p>Check the lock and operation contactor;</p>
Err 39	The motor overheating	Motor overheating relay input is valid	<ol style="list-style-type: none"> 1. Check whether the motor is used correctly and whether the motor is damaged; 2. Improve the heat dissipation condition of the motor;
Err 40	The elevator operating conditions do not meet the requirements	The elevator operation set time to	<ol style="list-style-type: none"> 1. The elevator speed is too low or the floor height is too high; 2. The elevator is used for too long time and needs to be maintained;
Err 55	DSP communication protection	The connection line between the drive board and the control board is abnormal	<ol style="list-style-type: none"> 1. Check the connection line between the drive board and the logic board;